

Operating and Maintenance Instructions

Outdoor - motor drive
UMPlus

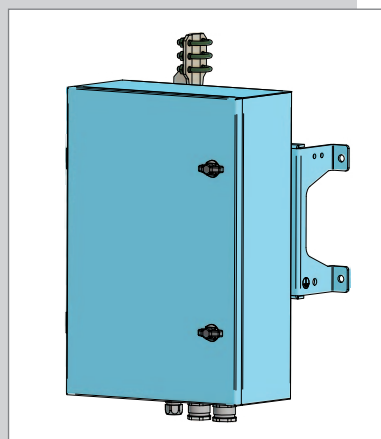

ELEKTROTECHNISCHE WERKE
FRITZ DRIESCHER & SÖHNE GMBH

85366 Moosburg • Tel.: +49 8761 681-0 • Fax: +49 8761 681-137
www.driescher.de infoservice@driescher.de



Table of Contents

1	INTRODUCTION	4
1.1	Notes on this manual	4
1.1.1	General note	4
1.1.2	Use of symbols / legend	4
1.2	Product description	4
1.2.1	General	4
1.2.2	Assemblies and functional elements	5
2	SAFETY	6
2.1	Intended use / guarantee	6
2.2	Personnel selection and necessary qualifications	6
2.3	Organisational safety	6
2.4	Dangers caused by the switching device	7
2.4.1	Danger due to moving parts	7
2.4.2	Danger due to electrical supply voltage	7
2.4.3	Danger due to emergency hand crank	7
2.5	Safety installations	8
2.5.1	Electrical safety installations	8
2.5.2	Mechanical safety installations	8
2.6	Checking the safety installations	9
2.6.1	Checking the electrical safety installations	9
2.6.2	Checking the mechanical safety installations	9
3	OPERATING ELEMENTS	10
4	COMMISSIONING	11
4.1	Transport and storage	11
4.2	Mounting the motor drive	11
4.2.1	Mounting Operating crank	11
4.2.2	Attachment	12
4.2.3	Establishing the earthing potential connection	12
4.2.4	Connecting the motor drive	12
4.2.5	Functional check	12

5	OPERATION	13
5.1	Work station	13
5.2	Visual check	13
5.2.1	Commissioning	13
5.2.2	Temporary decommissioning	13
5.2.3	Decommissioning	13
6	MAINTENANCE	14
6.1	Maintenance Intervals	14
6.2	Service address	15
7	TECHNICAL DATA	16
7.1	Required lubricants	16
7.2	Current consumption and operating time	16
7.3	Cable dimensioning	17
8	DISPOSAL	17
9	CIRCUIT DIAGRAM, Sample	18
10	DRAWING	19

B776.UMPlus

1 Introduction

Thank you for choosing one of our products. We hope it gives you many hours of successful and problem-free operation.

The Outdoor motor drive UMPlus has been specially designed and manufactured to meet your requirements.

Do you have any questions you would like to ask us? We look forward to hearing from you.

www.driescher.de

1.1 Notes on this manual

1.1.1 General note

This operating and maintenance manual contains all information and descriptions required to operate the motor drive. This document was created with the utmost care. Any suggestions or comments would be gratefully received.

To make the instructions in this manual easier to follow, the descriptions are accompanied by figures and schematic diagrams of the switching device or its assemblies.

1.1.2 Use of symbols / legend

The following symbols are used in this manual in addition to the warning notices outlined in the chapter *Safety*:



WARNING: Warns of danger to people. Failure to comply with the warning indicated by this symbol will result in severe injuries.



CAUTION: Failure to comply with the warning indicated by this symbol could result in injuries.



ATTENTION: Warns of possible material damage or malfunctions. Technical information requiring particular attention.

1.2 Product description

1.2.1 General

The motor drive UMPlus is used to actuate outdoor switching devices and it is generating a max. torque of 350 Nm and a stroke of approx. 200 mm during its actuating angle of 90°.

Several motor and control supply voltages are available: 110/220 V DC and 230 V AC. The motor operating time depends on the upcoming torque at the operating shaft. In case of a power supply breakdown it is possible to operate by means of an emergency hand crank. The door can be locked with a padlock.

The mechanical life-time is 10000 switching cycles.



With delivery of the motor drive UMPlus, the operating crank with the head of clamping crank is not mounted, the assembly on site, is depending on the mounting situation, see *chapter "Commissioning"*.



The connecting situation between the UMPlus and switch is described in the "operating manual shift linkage".

B776.UMPlus

1.2.2 Assemblies and functional elements

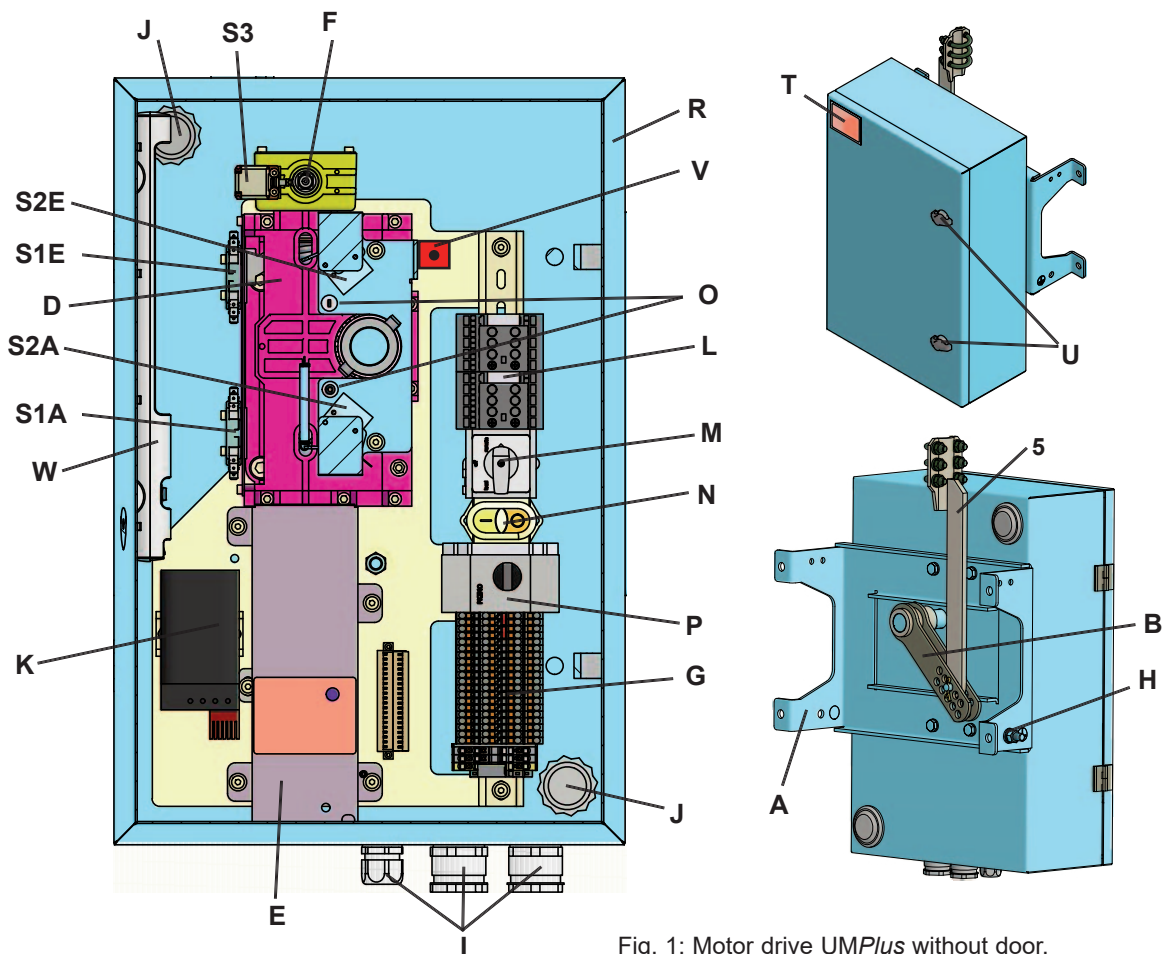

Fig. 1: Motor drive UMPlus without door, top right: with door, on the bottom right: reverse side with operating crank

- | | | | |
|---|--|-----|---|
| A | Support frame | L | Control contactor |
| B | Operating crank with head of clamping crank (5), (for linkage pipe 1"), not mounted, see page 10 | M | Change over switch Local/OFF/Remote |
| C | Emergency hand crank ¹ , see page 10 | N | Local ON / OFF push buttons |
| D | Main gear box | O | Position indicator ON / OFF |
| E | Cover Motor | P | Protective motor switch |
| F | Motor with Friction clutch | R | Stainless steel housing |
| G | Terminal connections | S2A | Pilot switch motor drive position „OFF“ |
| H | Earthing terminal M12 | S2E | Pilot switch motor drive position „ON“ |
| I | Cable entry (1 x M25, 2 x M32) | S3 | Safety switch for emergency hand crank |
| J | Ventilation | T | Type plate |
| K | Heating with Thermostat | U | Door latch, lockable |
| | | V | Safety pilot switch door |
| | | W | Indoor lighting |

¹ as option

B776.UMPlus

2 Safety

2.1 Intended use / guarantee

This motor drive is intended for use under the conditions outlined in the section 7 *Technical data*.

Any use other than those outlined in this section is classed as an unintended use. It is prohibited to use the product in explosion environments.

Any of the following carried out without express written approval from the manufacturer:

- alterations or extensions
- using non-genuine spare parts
- repairs carried out by companies or persons not authorised by the manufacturer

could result in the guarantee becoming null and void.

2.2 Personnel selection and necessary qualifications

Persons working with the motor drive must

- be at least 18 years of age.
- have received sufficient training for the relevant tasks.
- be familiar and comply with the current valid rules and safety regulations.

The owner decides on the necessary qualifications for

- operators
- maintenance personnel
- repair personnel

The owner must ensure that only authorised personnel work on the motor drive.

Personnel learning to use or being introduced to the device, or operating the device as part of training may only work on the motor drive when supervised by an experienced member of staff!

All work on the motor drive may only be carried out by trained specialist personnel and in compliance with all valid regulations specified in the accident prevention regulations (UVVen).

2.3 Organisational safety

The owner must ensure that this operating and maintenance manual is always in the immediate vicinity of the persons responsible for assembling, operating and carrying out maintenance work on the motor drive..

B776.UMPlus

2.4 Dangers caused by the motor drive

The possible danger sources of the motor drive are outlined below. Thorough introductory sessions and training for operators help minimise the danger to both people and equipment.

Carrying out regular checks on the knowledge levels and compliance with safety regulations contributes significantly to accident-free operation over the long term.

2.4.1 Danger due to moving parts



WARNING: The motor drive has moving components, some of which can be moved remotely (electrical and/or mechanically) with significant force. Touching these parts poses a risk of personal injury or material damage.



Before starting work, it is important to ensure that there is no danger from moving part.

During maintenance work, components moved electromechanically must be shut down by switching OFF the operating voltage.

2.4.2 Danger due to electrical supply voltage



WARNING: When operating electrical switching devices, components in the immediate vicinity are supplied with dangerous voltage. Touching these parts poses a risk of personal injury or material damage.



The danger zone of the switching device may only be accessed by persons who are aware of the electrical dangers thanks to specialist training, knowledge and experience and can implement the necessary occupational health and safety measures.

Other people may only enter the danger zone when accompanied by the persons listed above.

2.4.3 Danger due to emergency hand crank



CAUTION: If the emergency hand crank is not pressed against the spring pressure onto the emergency hand crank connection, it falls down and could cause personal injury or material damage. To help prevent personal injury and material damage, the emergency hand crank must be removed from the emergency hand crank connection after every use.



ATTENTION: The emergency hand crank must be operated with both hands when used.

B776.UMPlus

2.5 Safety installations

For the protection of both personnel and the product, safety installation help prevent accidents or material damage caused by moving parts and assemblies.

The operator must ensure that trained personnel

- check all safety installations regularly
- remove any problems on the safety installations immediately
- secure the switching device against being switched ON if not all safety installations

are present and working.

2.5.1 Electrical safety installations

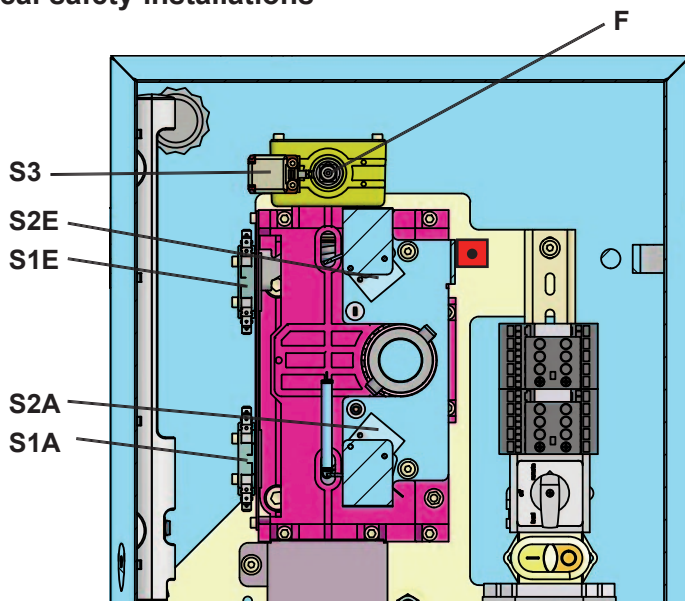

Fig. 2

	<u>Component / assembly</u>	<u>Function</u>
S1E	Signaling contact „EIN“	Contact for command „ON“
S1A	Signaling contact „AUS“	Contact for command „OFF“
S2E	Auxiliary switch „ON“	Reports the end position „ON“
S2A	Auxiliary switch „OFF“	Reports the end position „OFF“
S3	Emergency hand crank ¹ safety switch	Interrupts the power supply to the motor, when the emergency hand crank is inserted

2.5.2 Mechanical safety installations

	<u>Component / assembly</u>	<u>Function</u>
F	Emergency hand crank ¹ pressing-off fixture ¹	Presses an inserted emergency hand crank ¹ off the emergency hand crank connection (F) using spring pressure if the emergency hand crank is not activated (pressed in).

¹ as option

2.6 Checking the safety installations

2.6.1 Checking the electrical safety installations

S3 Emergency hand crank¹ switch (Fig. 2, 3, 4 and 10)

- Move the sliding sleeve (F) on the emergency hand crank connection against the spring pressure and hold, the safety switch (S3) switches.
- Apply the switch signal on the switching device (change the switch position), the motor drive must not start.
- Switch off the switch signal
- Release the sliding sleeve (F), it moves into its start position with the help of the springs
- Apply the switch signal on the motor drive (change the switch position), the motor drive must start up.

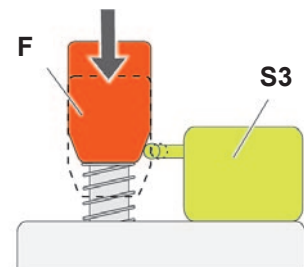

Fig. 3

S2A and S2E Auxiliary switch motor drive (Fig. 2)

Proceed as described under *chapter 4 - Functional check*.

2.6.2 Checking the mechanical safety installations

Emergency hand crank¹ pressing-off fixture (Fig. 2, 3, 4 and 10)

If the inserted emergency hand crank (C) is released, it is pressed off the emergency hand crank connection by the sliding sleeve (F) via spring pressure (10).

Ensure that the emergency hand crank cannot be left inserted on the emergency hand crank connection.

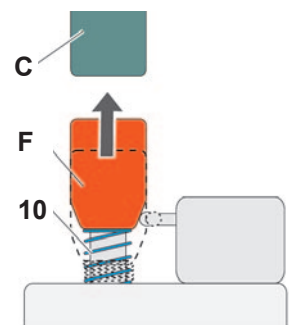

Fig. 4

¹ as option

B776.UMPlus

3 Operating elements

- Emergency hand crank¹ (C) for inserting on the emergency hand crank connection (F)



ATTENTION: The emergency hand crank must be operated with both hands when used.

- Local ON / OFF push buttons (N)
- Change over switch Local/OFF/Remote (M)

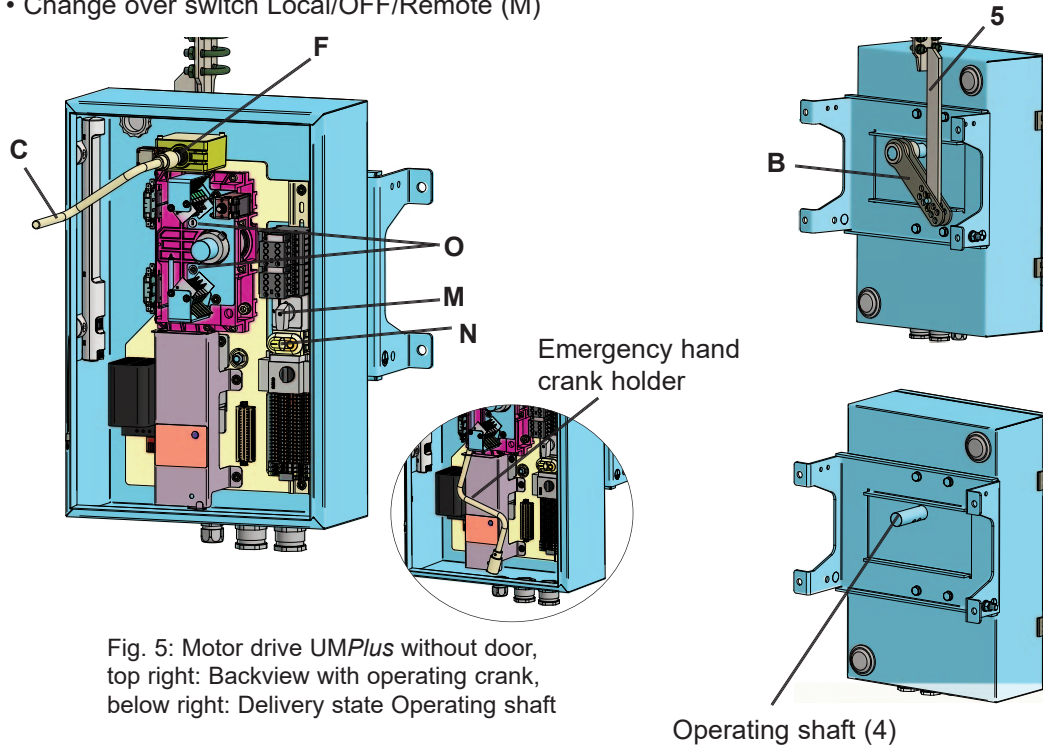

Fig. 5: Motor drive UMPlus without door, top right: Backview with operating crank, below right: Delivery state Operating shaft

- B Operating crank with head of clamping crank (5), (for linkage pipe 1“)
- Connection to shift linkage, mountable acc. to **mounting situation A or B**
- C Emergency hand crank¹
- F Connection for emergency hand crank
- M Change over switch Local/OFF/Remote
- N Local ON / OFF push buttons
- O Position indicator ON / OFF

¹ as option

4 Commissioning

4.1 Transport and storage

Once you have received the delivery please carefully unpack the motor drive and check for any transportation damage. Should you determine any damage please report this immediately and indicate the carrier. After unpacking, clean the motor drive and accessories to remove any contamination from packing material and protect against moisture and contamination prior to installation. To transport the motor drive only hold at the frame (A). Thoroughly clean the motor drive prior to putting into operation to remove dust with a clean dry cloth. Until they have been placed, keep the motor drive in a dry place and protected against the elements. The motor drive has to be stored vertical in installation position.

4.2 Mounting the motor drive

4.2.1 Mounting the operating crank

ATTENTION: The operating crank of the motor drive UMPlus has to be adjusted corresponding to the mounting situation on site, therefore insert the bolt (3) into the operating crank (4) (use outer drill hole, operating crank flush-mounted with operating shaft) and secure with the splint ($\varnothing 3,2 \times 2$ mm) gesichert.

- **Mounting situation A:** Operating crank (B) 45° upwards mounted - upon command ON, the operating crank rotate 90° in **downward** direction, to actuate the switch in position ON (see Fig.: 6).

- **Mounting situation B:** Operating crank (B) 45° downwards mounted - upon command ON, the operating crank rotate 90° in **upward** direction, to actuate the switch in position ON (see Fig.: 6).

- Connect the head of clamping crank (5) with the operating crank (B), attachment point 142 mm. Therefore mount the bolt (6) with the sleeve (7) and the both washers (8) and secure with the two splints ($\varnothing 4 \times 25$ mm) (see Fig. : 7).

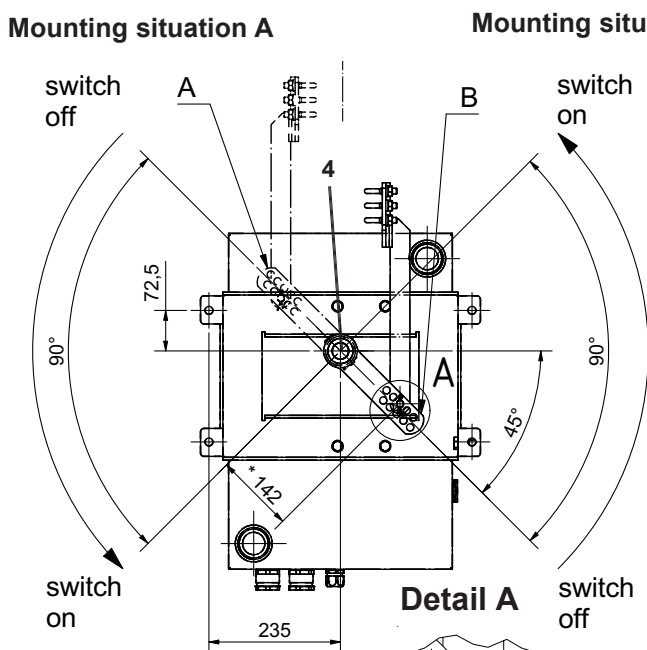

Fig. 6: Mounting the operating crank acc. to mounting situation

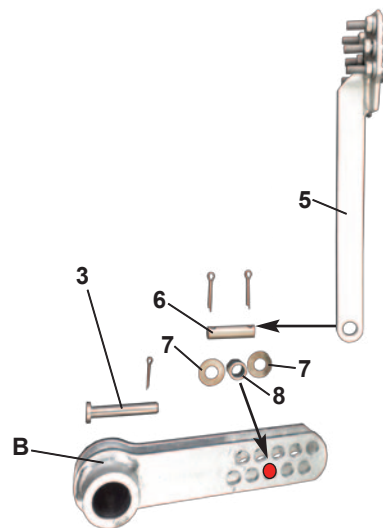

Fig. 7: Mounting the head of clamping crank

Stroke at 90° actuating (45°/45°)	
(min. 108 mm):	177 mm
(max. 184,5 mm):	261 mm
*(142 mm):	200 mm

B776.UMPlus

4.2.2 Attachment

ATTENTION: We recommend carrying out the assembly on a precisely aligned assembly system. Stresses on the motor drive can lead to malfunctions. It is recommended to use 4 pcs. M10 (minimum) screws (x) for tightening on the base frame (A). The motor drive is intended for vertical mounting position.
Tightening torque 32 Nm.

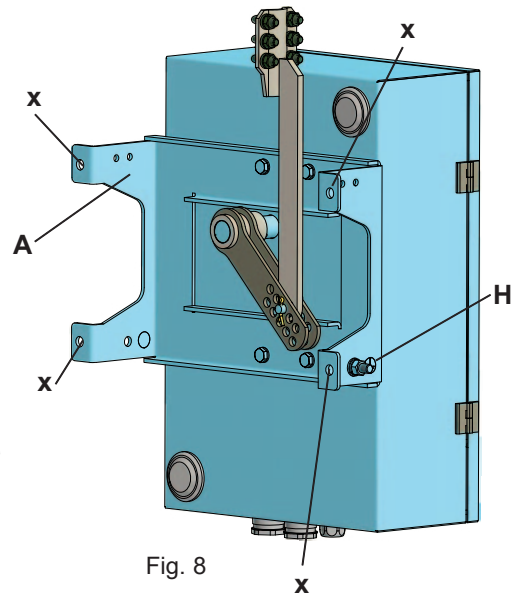

Fig. 8

4.2.3 Establishing the earthing potential connection

Connect the cable to the earthing potential (H) on the screw connection (M 12).
Tightening torque 75 Nm.

4.2.4 Connecting the motor drive

- Establish the motor drive power supply on the terminal connections (G*).
- * In accordance with circuit diagram (inside the door)

ATTENTION: We recommend monitoring the switch operating time via the operator control. The max. operating time should be less than 6 seconds between switch position ON and OFF.



ATTENTION: Design 220V DC according diagram EM3J 066A C111 19D

In stage of delivery, the motor and control voltage are always in common. The jumpers at terminal -X1, 11-12 and 13-14 are staked.

For separate motor and control voltage, the jumpers at terminal -X1, 11-12 and 13-14 must be removed!

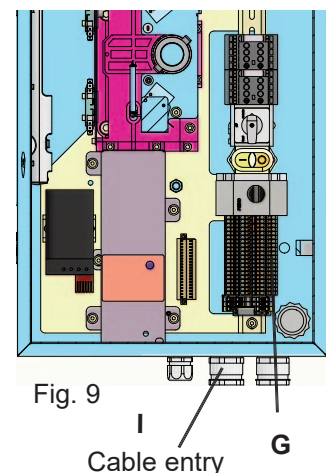

Fig. 9

Cable entry G

4.2.5 Functional check

Carrying out test switching cycles

Carry out 5 test switching cycles with the power supply disconnected.

- Carry out a functional check by using the emergency hand crank to move the switching device several times from switch position ON to its switch position OFF and back again. The drive components must reach their relevant end positions without problems and free from play.

Checking the auxiliary switches (S2A/S2E)

- Have the emergency hand crank ready.
- Bring the motor drive in a position between the end switching points ON and OFF (approx. half way).
- Bring the motor drive in switch position ON. The ON contact of the auxiliary switch to be checked must be switched.
- Bring the motor drive in switch position OFF. The OFF contact of the auxiliary switch to be checked must be switched.

B776.UMPlus

5 Operation

5.1 Work station

The owner must ensure that the work station complies with all valid regulations and has sufficient lighting.

5.2 Visual check



WARNING: Missing or loose components could result in personal injury or material damage. Check that all mechanical components are complete and secured in place. If faulty or loose mounting parts are detected on the motor drive, it may only be commissioned again after it has been repaired by an expert.

A check must be carried out to ensure that the safety installations are complete and functional (see *chapter 2.5*) prior to commissioning.

5.2.1 Commissioning

Once the entire assembly and successful functional check are complete, the motor drive is ready for use.

5.2.2 Temporary decommissioning

The automatic switch function of the motor drive can be decommissioned by disconnecting the power supply. Operation via the emergency hand crank is still possible.

5.2.3 Decommissioning

The motor drive can be decommissioned by disconnecting the power supply and all switch connections (switch cables and wires to the auxiliary switch).

B776.UMPlus

6 Maintenance

6.1 Maintenance intervals (recommended)

Interval	Activities
After 10000 switching cycles or 10 years	<p>Lubricate the following components of the motor drive with the lubricant Isoflex NBU² (see chapter 7.1) so that the interacting components are sufficiently lubricated:</p> <ul style="list-style-type: none"> • Guide rollers (15) on both sides, driver pin (21) inclusive guide rails (16) on both sides and connecting fork (17) • Ball and screw spindle drive (18) and both rolling-contact bearing (19) • Bevel gearing (20) and shifting sleeve (10) at the emergency manual drive (it is necessary to remove the covering (25)) • All moveable parts • Function check of the auxiliary switches (<i>S2A and S2E</i>, see Fig.: 1), protective motor switch (P), Emergency hand pilot switch (<i>S3</i>, see Fig.: 10), Heating with Thermostat (K) • Carry out a functional check (see chapter 4.2.5). <p>Attention: For the friction clutch (22) to work properly, it must not come into contact with lubricant.</p>

² See lubricants under chapter 7 Technical data.

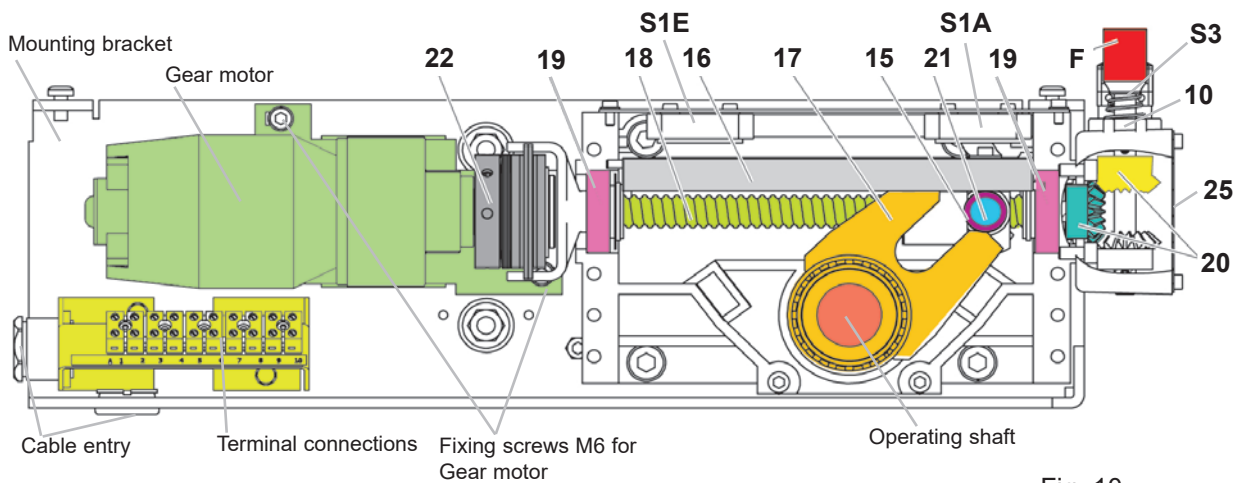

Fig. 10

B776.UMPlus

6.2 Service address

Our specialist personnel can be contacted by telephone in the event of faults or to answer any questions you may have with regard to the compatibility, assembly or maintenance, including outside business hours.

Please always provide the information on the type plates.

Phone +49 8761 681-0
E-mail service@driescher.de
Internet www.driescher.de

B776.UMPlus

7 Technical data

General

Dimensions (approx. LxWxH in mm)	600 x 500 x 334
Weight	approx. 40 kg
Rated power supply voltage (U _a)	48/110/220 V DC or 230 V AC
Rated power consumption	250 W
Maximum tightening torque	350 Nm
Degree of protection	IP 55
Mechanical life time	10000 switching cycles
Operating movement	90°
Operating time (load-dependent)	max. 6 sec.
Emergency hand crank	as option

Operating ambient conditions

Temperature / maximum daily average	-30° up to +55° / +35° Celsius
Class according to DIN EN 62271-1	Minus 25 Outdoor

Storage conditions

Storage conditions	dry and dust-free -30 up to +60 °Celsius vertical in installation position
--------------------	---

7.1 Required lubricants

Order no: ¹	Lubricate name / type	Manufacturer
1-49007015	Isoflex NBU 15	Klüber Lubrication

¹ At DRIESCHER

7.2 Current consumption and operating time

The motor drives can be delivered optionally for alternating voltage or direct voltage. The motor drive work on short-time duty. The motor supply voltage may not differ from the rated supply voltage from -15% to +10%.

Operating voltage U _a	Average current consumption in dependence to Starting loading cases [A]	Starting current max. [A]	Motor operating time at M _d 350 Nm [s]
	150 Nm		
48 V DC	3.6	16.2	5.5
110 V DC	2.3	8.9	3.5
220 V DC	1.0	5.8	4.1
230 V AC	1.3	6.3	3.2

B776.UMPlus

7.3 Cable dimensioning

In the table below you will find the maximum cable lengths of the motor supply voltages depending on the rated cross-section. The written values are valid for a maximum motor capacity of 150 Nm.

Cross section	0.75	1.0	1.5	2.5	4.0	6.0	10.0	[mm ²]
U _a 48 V DC	41	55	82	137	220	330	550	[m] Cable length
U _a 110 V DC	132	177	266	443	709	1063	1772	[m] Cable length
U _a 220 V DC / 230 V AC	577	770	1154	1924	3078	4618	7696	[m] Cable length

U_a = Motor supply voltage

8 Disposal



The switching device must be dismantled by qualified personnel.

It must be disposed of in an environmentally-friendly manner. Electrical components must not be disposed of as household waste. 2002/96/EC (WEEE)

B776.UMPlus

9 Circuit diagram, sample

