

DRIESCHER -
Indoor disconnectors
Indoor earthing switches
Indoor fuse holders

- Rated voltage U_r
12 kV - 40,5 kV
- Rated current I_r
630 A - 6300 A
- Rated short-time withstand
current I_k
up to 80 kA

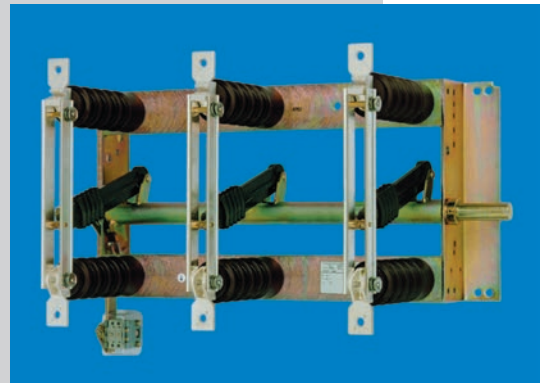
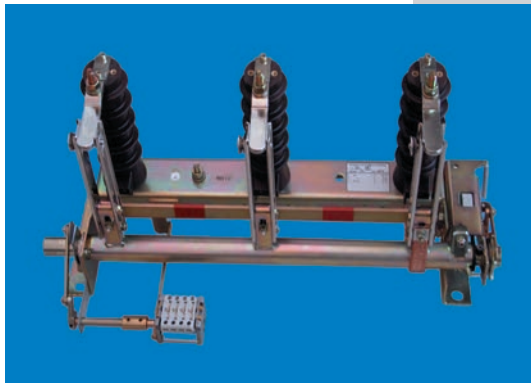

ITr

ELEKTROTECHNISCHE WERKE
FRITZ DRIESCHER & SÖHNE GMBH

D-85366 Moosburg • Phone: +49 8761 681-0 • Fax: +49 8761 681-137
www.driescher.com infoservice@driescher.de



DRIESCHER - indoor disconnectors – indoor fuse holders – indoor earthing switches

in accordance with EN 62271-102

Contents

- 2 General
- 3 General, operating conditions, technical description
- 4 3-pole indoor earthing switch ES 12-... ; (U_r 12 kV)
- 5 3-pole indoor earthing switch ES 17,5-... ; (U_r 17,5 kV)
- 7 3-pole indoor earthing switch ES 24-... ; (U_r 24 kV)
- 10 3-pole indoor earthing switch ES 36-... ; (U_r 36 kV and 38,5 kV)
- 11 3-pole indoor disconnector ITr 12-...-... ; (U_r 12 kV)
- 15 3-pole indoor disconnector ITr 17,5-...-... ; (U_r 17,5 kV)
- 20 3-pole indoor disconnector ITr 24-...-... ; (U_r 24 kV) with flat connection
- 25 3-pole indoor disconnector ITr 24-...-... ; (U_r 24 kV) with upright connection
- 29 3-pole indoor disconnector ITr 36-...-... ; (U_r 36 kV)
- 31 3-pole indoor disconnector ITr 38,5-...-... ; (U_r 38,5 kV)
- 33 3-pole indoor disconnector ITr 36/38,5-...-... ; (U_r 40,5 kV)
- 35 1-pole indoor disconnector ITr ...-630-20-1 and ITr ...-1600-40-1; (U_r 12/ $\sqrt{3}$ kV, 24/ $\sqrt{3}$ kV and 36/ $\sqrt{3}$ kV)
- 37 2-pole indoor disconnector ITr ...-630-20-2; (U_r 12 - 36 kV)
- 38 3-pole indoor changeover disconnector ITru 12-630-20 and ITru 12-1600-40; (U_r 12 kV)
- 40 3-pole indoor changeover disconnector ITru 24-...-... and ITru 36-630-50; (U_r 24 kV and 36 kV)
- 42 Indoor fuse holders for HV-HBC fuses with up to 200 A rated current
- 43 Notes

General

The various 3-pole **earthing switch ES** models can be used at rated voltages of 12 kV, 17.5 kV, 24 kV, 36 kV and 38.5 kV. 20 kA, 31.5 kA, 50 kA, 63 kA and 72 kA have been specified as rated short-time withstand currents.

Earthing switches up to a rated short-time withstand current of 31.5 kA have a short-circuit making capacity and are categorised under electrical class E1. For rated short-time withstand currents of 50 kA and above, the earthing switches do not have a short-circuit making capacity and are classified accordingly under electrical class E0. 1 and 2-pole earthing switches are available on request.

Our various 1, 2 and 3-pole **disconnecter ITr** models are designed for use in a rated voltage range of between 12 kV and 40.5 kV, and a rated current range of between 630 A and 6300 A. Depending on the model, the rated short-time withstand current has been successfully demonstrated up to 80 kA for a duration of 1 or 3 seconds. The disconnectors listed are designed to switch off the power in medium voltage networks.

All switching devices have undergone a type test according to EN 62271-102.

Each switching device is accompanied by a set of instructions (B731) for transport, assembly and commissioning.

General

Explanation of the mechanical and electrical classes:

Mechanical classes (in accordance with EN 62271-102)

for disconnector class M0 = 1.000 mechanical switching operations

for disconnector class M1 = 2.000 mechanical switching operations

for disconnector class M2 = 10.000 mechanical switching operations

for earthing switch class M0 = 1.000 mechanical switching operations

Electrical class for earthing switches

E0 = without short-circuit making capacity

E1 = with short-circuit making capacity for 2 making operations

Explanation of the type designation:

ES 24-20 (example)

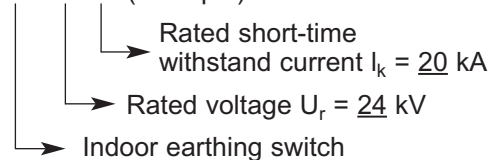

ITr 12-1600-40 (example)

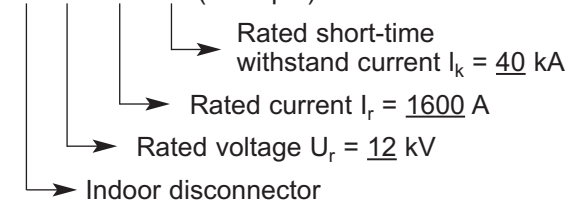

The disconnectors and earthing switches are also available in single and multi-pole versions and are classified according to the number of added poles.
(e.g. 4-pole disconnector: ITr 24-1600-20-4)

Operating conditions

The devices can be operated up to an installation altitude of 1000 m above sea level. In the case of installation altitudes over 1000 m, it is necessary to correct the rated insulation level on the switching device.

The switching devices are designed for use under normal operating conditions in accordance with EN 62271-1.

Additional applicable atmospheric limit values include the following:

Ambient temperature:

Highest ambient temperature: +40°C

Highest average temperature over 24 hours: +35°C

Lowest ambient temperature: - 5°C

(in accordance with „minus 5 indoors“ class)

Technical description

General

The earthing switches for the E1 class are generally equipped with a switch spring to facilitate a rapid switch-on process.

The base frames of the switching devices are electro-galvanised and chromated. Current paths are made of electrolytic copper and are galvanically silver plated. Rust-proof compression springs ensure sufficient contact pressure for the entire service life of the product.

Design features

All DRIESCHER disconnectors and earthing switches are generally equipped with a continuous drive shaft ($\varnothing=30$ mm).

This makes it possible to attach a motor drive on either the left or right-hand side.

Disconnectors with a rated current of 2500 A and higher have contact elements with a silver-graphite coating on the impact side.

DRIESCHER – 3-pole indoor earthing switch

ES 12-... ; (Ur 12 kV)

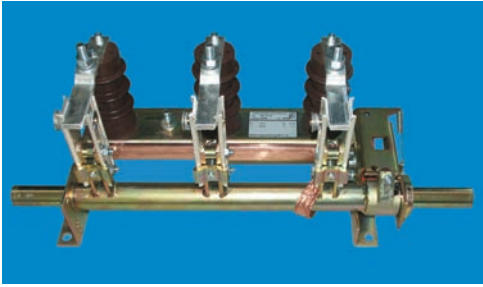

Switch type	ES 12-20	ES 12-31,5	ES 12-50
Rated voltage	U_r 12 kV	12 kV	12 kV
Rated frequency	f_r 50/60 Hz	50/60 Hz	50/60 Hz
Rated short-time withstand current	I_k 20 kA	31.5 kA	50 kA
Rated short-circuit duration	t_k 3 s	3 s	1 s
Rated peak withstand current	I_p 50 kA	80 kA	125 kA
Rated short-circuit making current	I_{ma} 50 kA	80 kA	–
Rated lightning impulse withstand voltage U_p			
- phase to earth	75 kV	75 kV	75 kV
Rated power frequency withstand voltage U_d			
- phase to earth	28 kV	28 kV	28 kV
Diagram number	096806	096809	111746
Mechanical service life	M1	M1	M1
Electrical class	E1	E1	E0
Weight (approx.)	19 kg	22 kg	50 kg
Phase spacing p, mm	155/210/250	210/250	210

Accessories:

- Auxiliary switch
- Motor drive (UM 10 and UM 50)
- Mechanical interlocking device
- Optional: electrical class E0

Diagram for ES 12-20 / Diagram number 096806 and ES 12-31,5 / Diagram number 096809

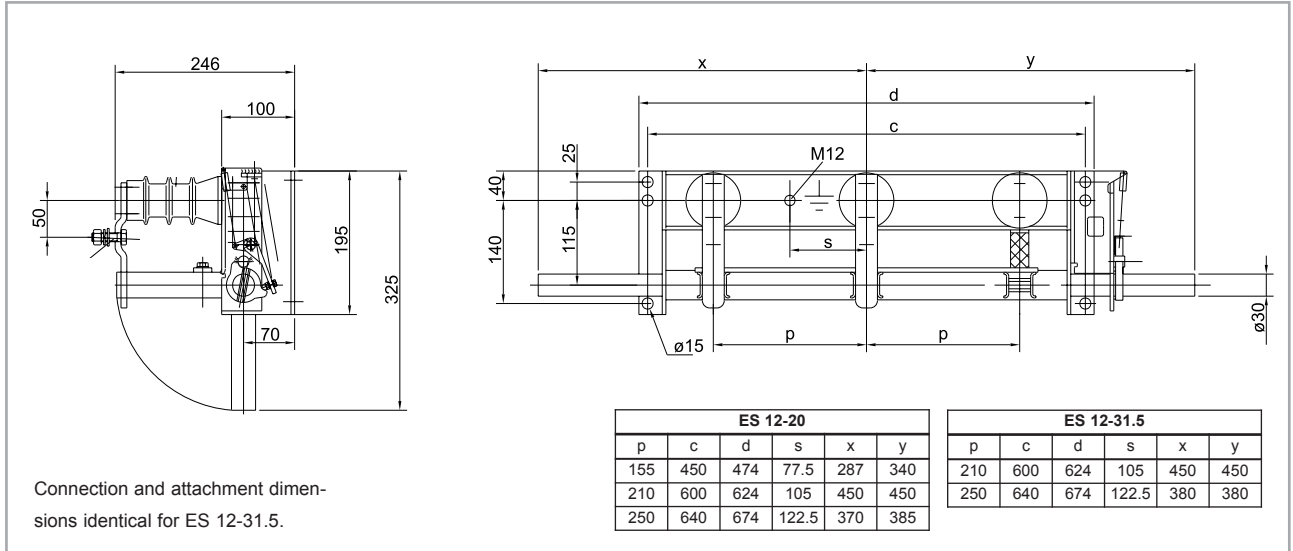
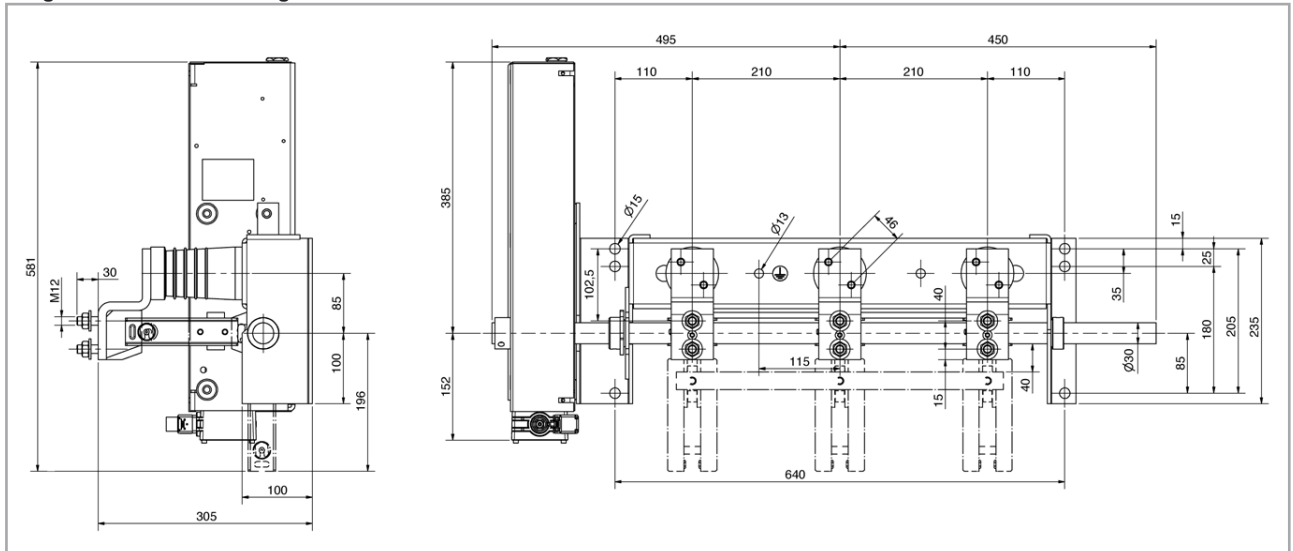
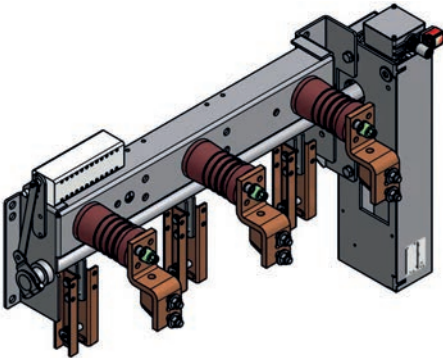

Diagram for ES 12-50 / Diagram number 111746



DRIESCHER – 3-pole indoor earthing switch

ES 17,5-... ; (Ur 17,5 kV)



Accessories:

- Auxiliary switch
- Motor drive (UM 10 and UM 50)
- Mechanical interlocking device

Switch type	ES 17,5-50	ES 17,5-63	ES 17,5-72
Rated voltage	U_r 17,5 kV	17,5 kV	17,5 kV
Rated frequency	f_r 50/60 Hz	50/60 Hz	50/60 Hz
Rated short-time withstand current	I_k 50 kA	63 kA	72 kA
Rated short-circuit duration	t_k 1 s	1 s	1 s
Rated peak withstand current	I_p 130 kA	164 kA	197 kA
Rated lightning impulse withstand voltage	U_p		
- phase to earth	95 kV	95 kV	95 kV
Rated power frequency withstand voltage	U_d		
- phase to earth	38 kV	38 kV	38 kV
Diagram number	115702	115712	117630
Mechanical service life	M0	M0	M0
Electrical class	E0	E0	E0
Weight (approx.)	50 kg	60 kg	65 kg
Phase spacing p, mm	275	275	300

Diagram for ES 17.5-50 / Diagram number 115702

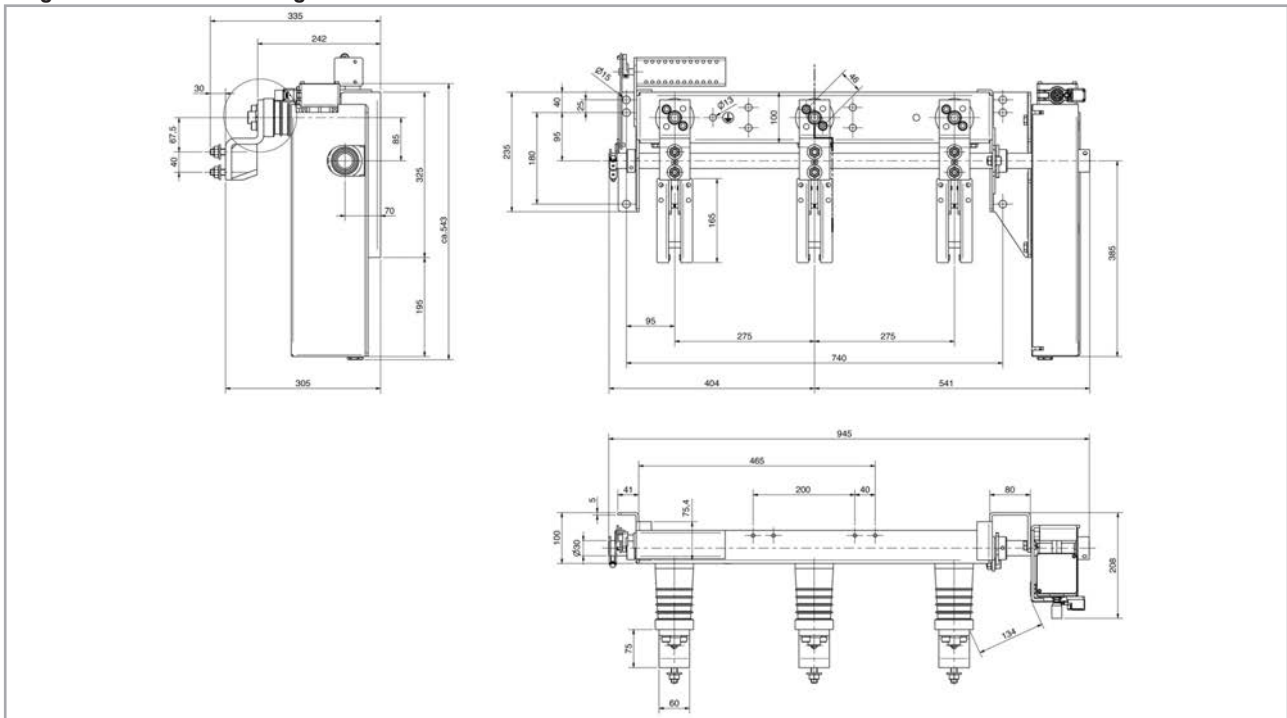

DRIESCHER – 3-pole indoor earthing switch

ES 17,5-... ; (Ur 17,5 kV)

Diagram for ES 17,5-63 / Diagram number 115712

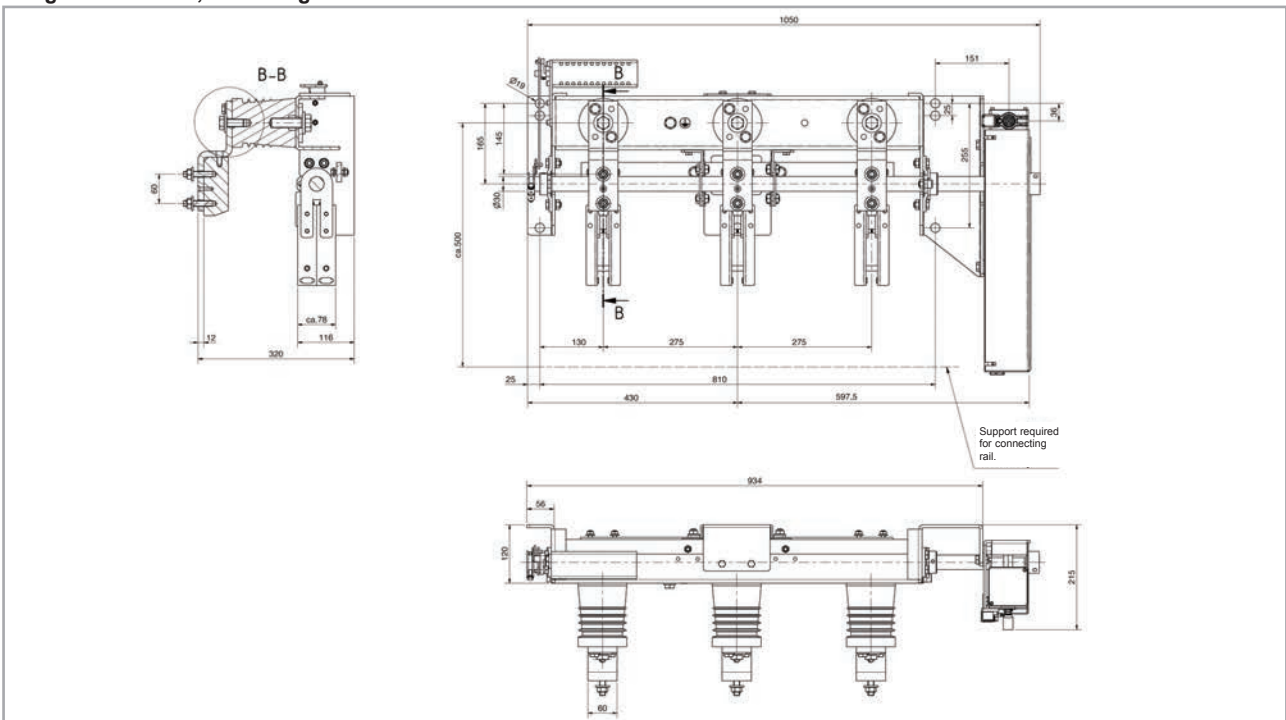
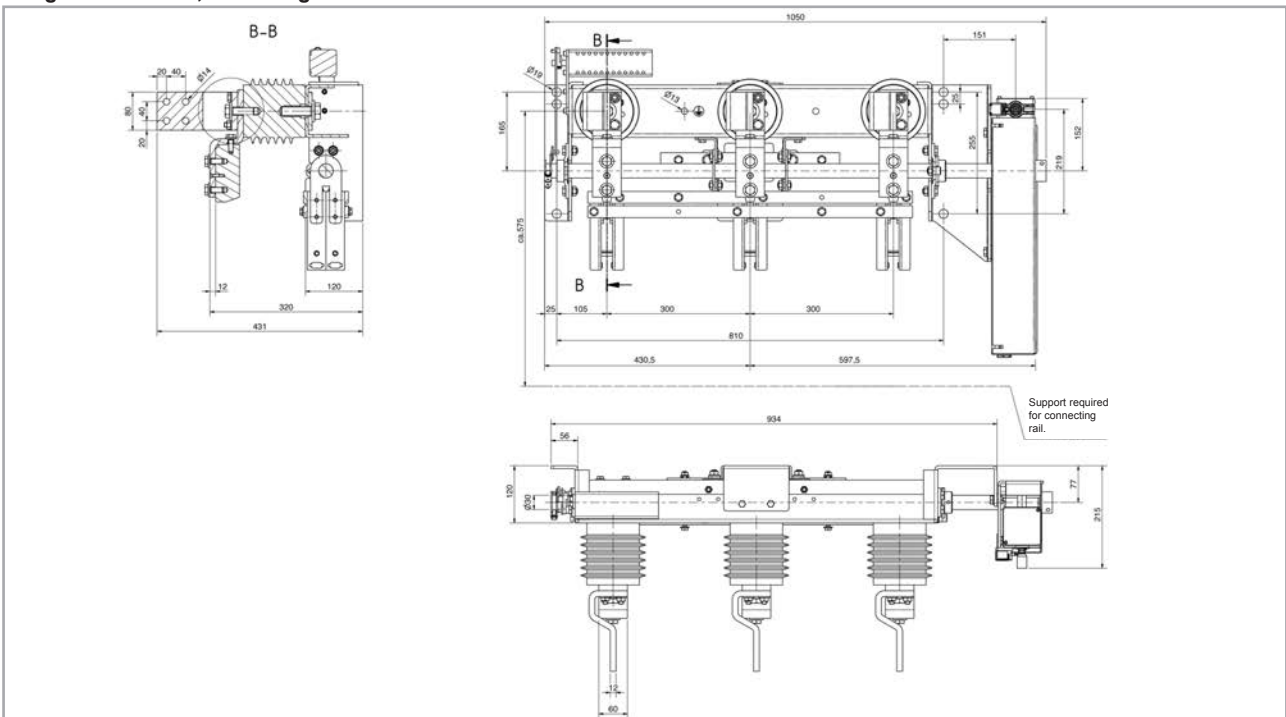
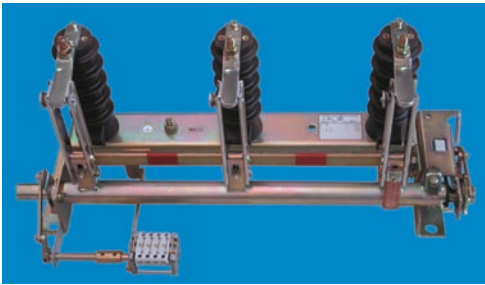

Diagram for ES 17,5-72 / Diagram number 117630



DRIESCHER – 3-pole indoor earthing switch

ES 24-... ; (Ur 24 kV)



Accessories:

- Auxiliary switch
- Motor drive (UM 10 and UM 50)
- Mechanical interlocking device
- Optional: electrical class E0

Switch type		ES 24-20	ES 24-31,5
Rated voltage	U_r	24 kV	24 kV
Rated frequency	f_r	50 Hz	50 Hz
Rated short-time withstand current	I_k	20 kA	31,5 kA
Rated short-circuit duration	t_k	3 s	3 s
Rated peak withstand current	I_p	50 kA	80 kA
Rated short-circuit making current	I_{ma}	50 kA	80 kA
Rated lightning impulse withstand voltage	U_p		
- phase to earth		125 kV	125 kV
Rated power frequency withstand voltage	U_d		
- phase to earth		50 kV	50 kV
Diagram number		096807	096810
Mechanical service life		M1	M1
Electrical class		E1	E1
Weight (approx.)		24 kg	27 kg
Phase spacing p, mm		210/250/275	250/275

Switch type		ES 24-50	ES 24-63	ES 24-72
Rated voltage	U_r	24 kV	24 kV	24 kV
Rated frequency	f_r	50 Hz	50 Hz	50 Hz
Rated short-time withstand current	I_k	50 kA	63 kA	72 kA
Rated short-circuit duration	t_k	1 s	1 s	1 s
Rated peak withstand current	I_p	130 kA	164 kA	197 kA
Rated lightning impulse withstand voltage	U_p			
- phase to earth		125 kV	125 kV	125 kV
Rated power frequency withstand voltage	U_d			
- phase to earth		50 kV	50 kV	50 kV
Diagram number		115827	115834	117988
Mechanical service life		M1	M1	M1
Electrical class		E0	E0	E0
Weight (approx.)		55 kg	60 kg	90 kg
Phase spacing p, mm		300	300	300

Diagram for ES 24-20 / Diagram number 096807

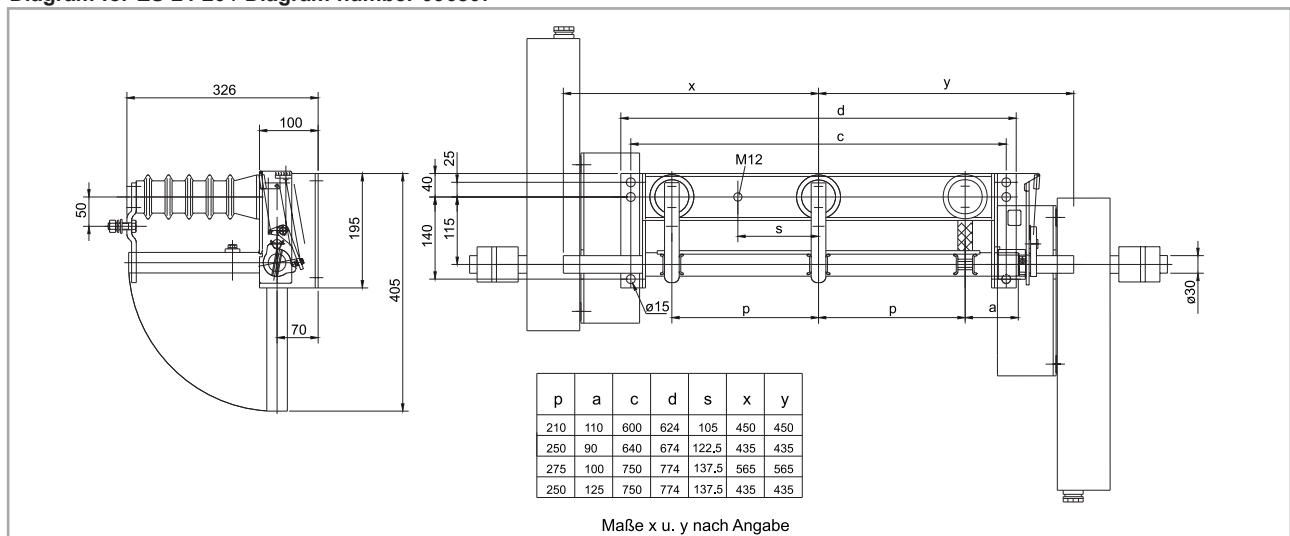

DRIESCHER – 3-pole indoor earthing switch

ES 24-... ; (Ur 24 kV)

Diagram for ES 24-31,5 / Diagram number 096810

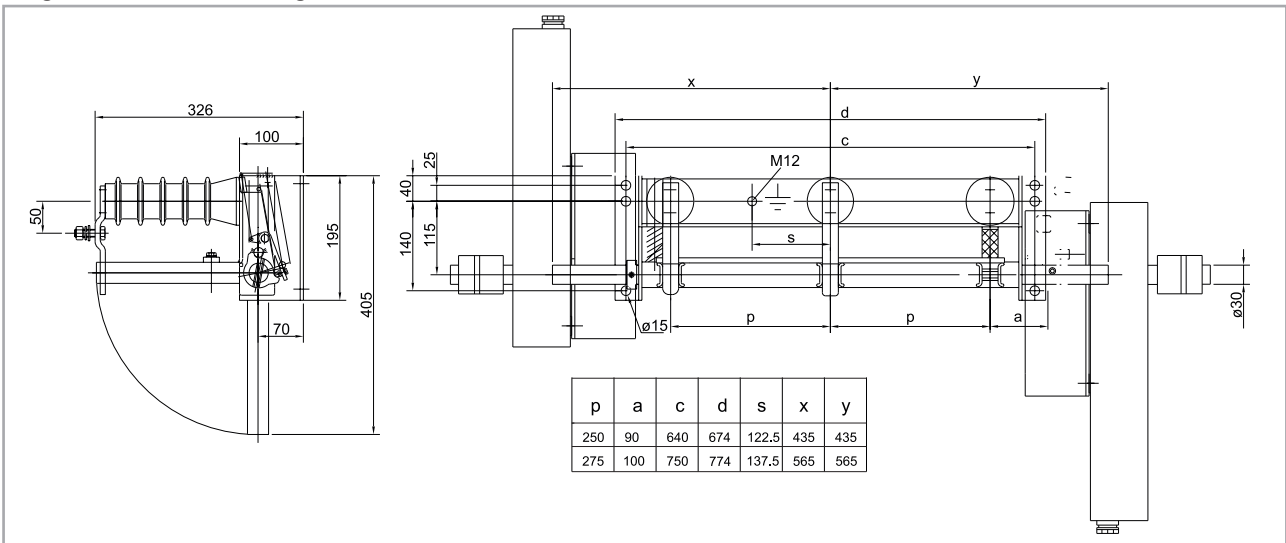
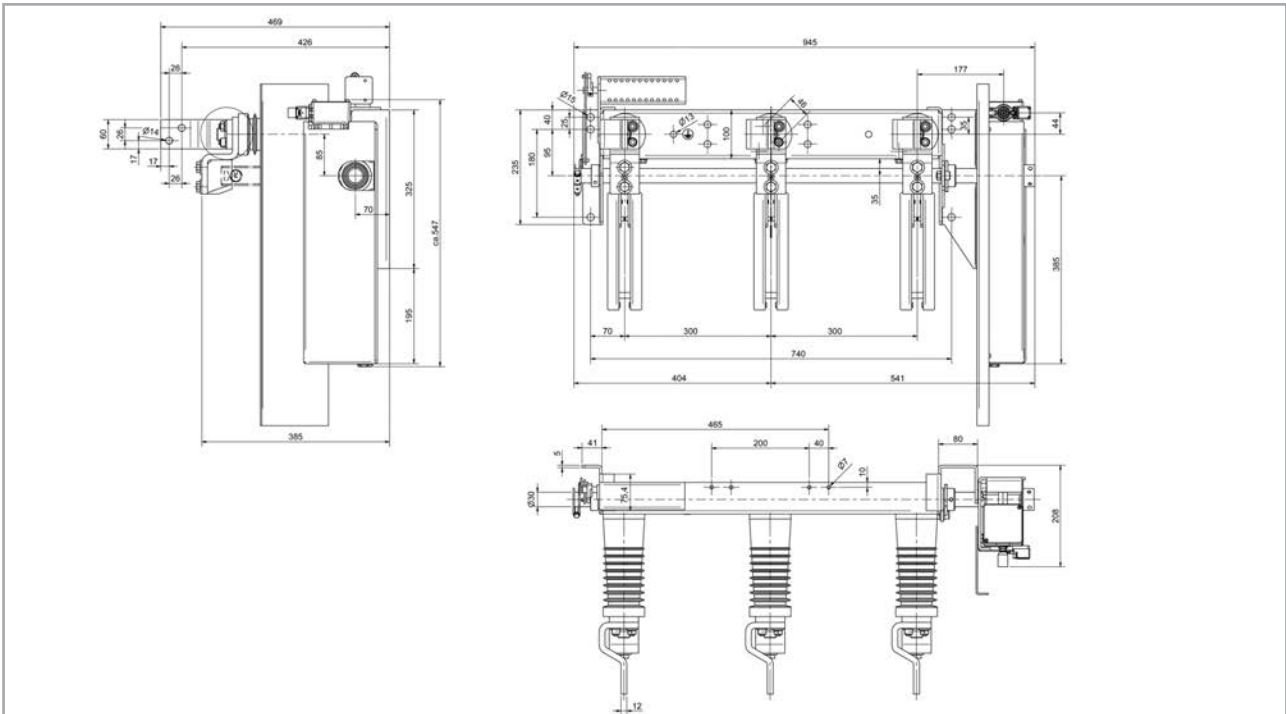

Diagram for ES 24-50 / Diagram number 115827



DRIESCHER – 3-pole indoor earthing switch

ES 24-... ; (Ur 24 kV)

Diagram for ES 24-63 / Diagram number 115834

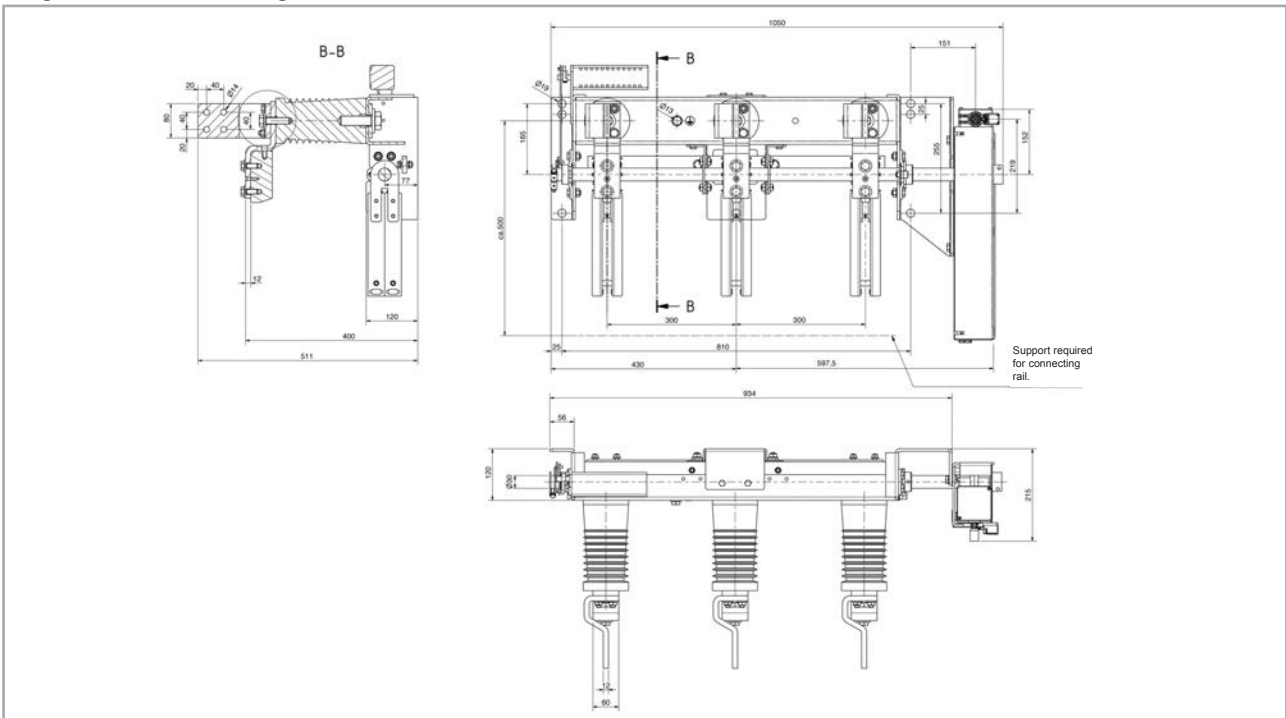
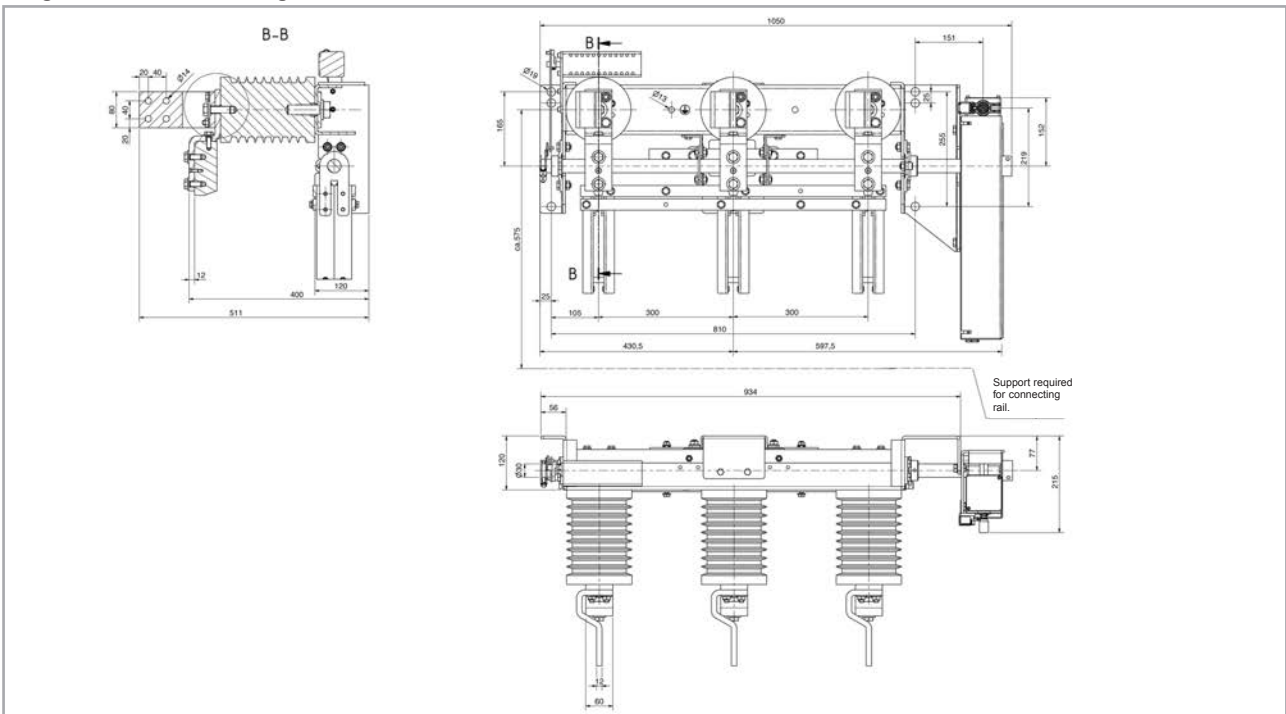

Diagram for ES 24-72 / Diagram number 117988



DRIESCHER – 3-pole indoor earthing switch

ES 36... ; (Ur 36 and 38,5 kV)

Switch type	ES 36-20		ES 36-31,5		
Rated voltage	U_r	36 kV	36 kV	38,5 kV	38,5 kV
Rated frequency	f_r	50 Hz	50 Hz	50 Hz	50 Hz
Rated short-time withstand current	I_k	20 kA	31,5 kA	20 kA	31,5 kA
Rated short-circuit duration	t_k	3 s	3 s	3 s	3 s
Rated peak withstand current	I_p	50 kA	80 kA	50 kA	80 kA
Rated short-circuit making current	I_{ma}	50 kA	50 kA*	50 kA	50 kA*
Rated lightning impulse withstand voltage	U_p				
- phase to earth		170 kV	170 kV	180 kV	180 kV
Rated power frequency withstand voltage	U_d				
- phase to earth		70 kV	70 kV	80 kV	80 kV
Diagram number		096808	096811	103605	104999
Mechanical service life		M1	M1	M1	M1
Electrical class		E1	E1	E1	E1
Weight (approx.)		40 kg	43 kg	44 kg	46 kg
Phase spacing p, mm		275**/400	400	275**/400	400

Accessories:

- Auxiliary switch
- Motor drive (UM 10 a. UM 50)
- Mechanical interlocking device
- Optional: electrical class E0

*Short-circuit making current I_{ma} restricted to 50 kA.

**With phase barriers only

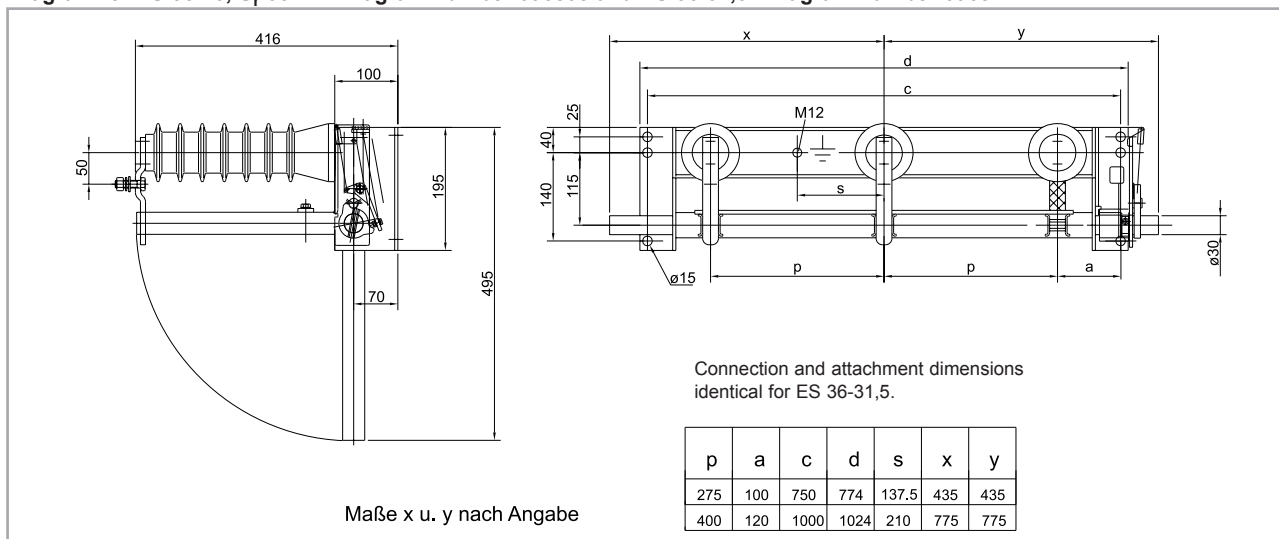
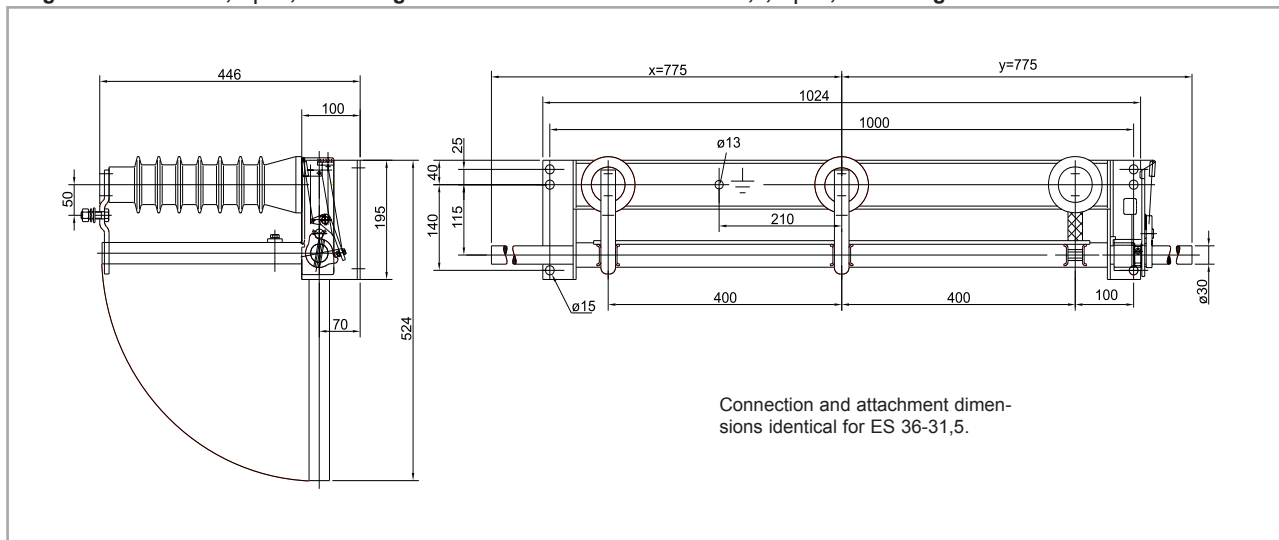
Diagram for ES 36-20, U_r 36 kV / Diagram number 096808 and ES 36-31,5 / Diagram number 096811Diagram for ES 36-20, U_r 38,5 kV / Diagram number 103605 and ES 36-31,5, U_r 38,5 kV / Diagram number 104999

DRIESCHER – 3-pole indoor disconnecter

ITr 12-....-... ; (Ur 12 kV, Ir 630 - 6300 A)

Switch type	ITr 12-630-20	ITr 12-1600-40	ITr 12-2500-40	ITr 12-2500-50
Rated voltage	U_r 12 kV	12 kV	12 kV	12 kV
Rated frequency	f_r 50/60 Hz	50/60 Hz	50/60 Hz	50/60 Hz
Rated current	I_r 630 A	1600 A	2500 A	2500 A
Rated short-time withstand current	I_k 20 kA	40 kA	40 kA	50 kA
Rated short-circuit duration	t_k 3 s	3 s	3 s	1 s
Rated peak withstand current	I_p 50 kA	100 kA	100 kA	130 kA
Rated lightning impulse withstand voltage	U_p			
- phase to earth	75 kV	75 kV	75 kV	75 kV
- via the isolating distance	85 kV	85 kV	85 kV	85 kV
Rated power frequency withstand voltage	U_d			
- phase to earth	28 kV	28 kV	28 kV	28 kV
- via the isolating distance	32 kV	32 kV	32 kV	32 kV
Diagram number	099824	116715	100813	116972
Mechanical service life	M2	M2	M1	M1
Motor drive	Optional	Optional	Optional	Optional
Optional Earthing switch	ES 12-20	ES 12-31,5	ES 12-31,5	ES 12-31,5
Weight (approx.)	20 kg	32 kg	55 kg	60 kg
Phase spacing p, mm	155/210	210	210	210



Fig.: ITr 12-1600-40

Accessories:

- Auxiliary switch
- Motor drive (UM 10 and UM 50)
- Earthing switch
- Mechanical interlocking device

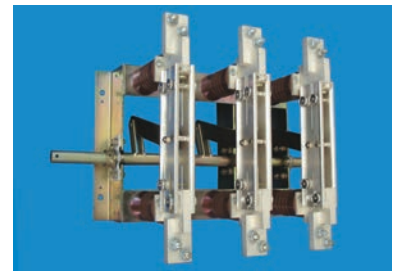

Fig.: ITr 12-2500-40

Switch type	ITr 12-4000-50	ITr 12-6300-63
Rated voltage	U_r 12 kV	12 kV
Rated frequency	f_r 50/60 Hz	50/60 Hz
Rated current	I_r 4000 A	6300 A
Rated short-time withstand current	I_k 50 kA	63 kA
Rated short-circuit duration	t_k 3 s	3 s
Rated peak withstand current	I_p 125 kA	160 kA
Rated lightning impulse withstand voltage	U_p	
- phase to earth	75 kV	75 kV
- via the isolating distance	85 kV	85 kV
Rated power frequency withstand voltage	U_d	
- phase to earth	28 kV	28 kV
- via the isolating distance	32 kV	32 kV
Diagram number	103229	110310
Mechanical service life	M1	M1
Motor drive	standard UM10	standard UM10
Optional Earthing switch	ES 12-31,5	ES 12-31,5
Weight (approx.)	91 kg	125 kg
Phase spacing p, mm	250	350

DRIESCHER – 3-pole indoor disconnecter

ITr 12-...-... ; (Ur 12 kV, Ir 630 and 1600 A)

Diagram for ITr 12-630-20 / Diagram number 099824

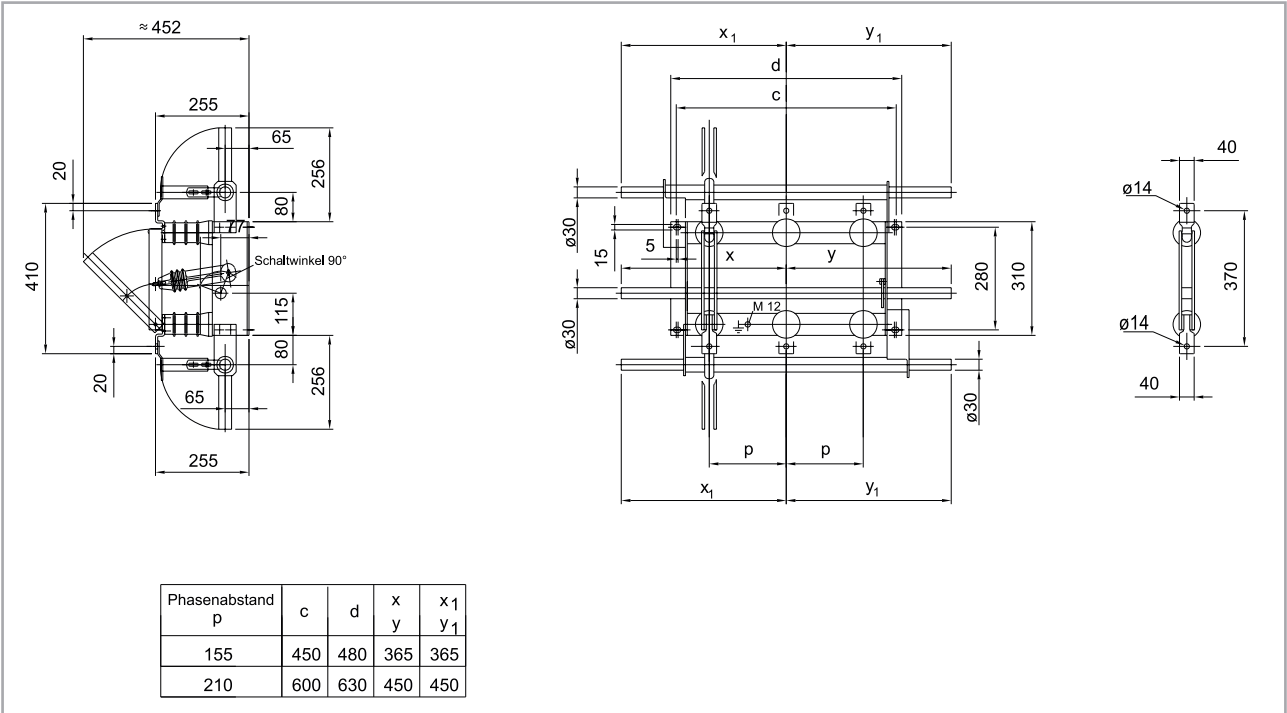
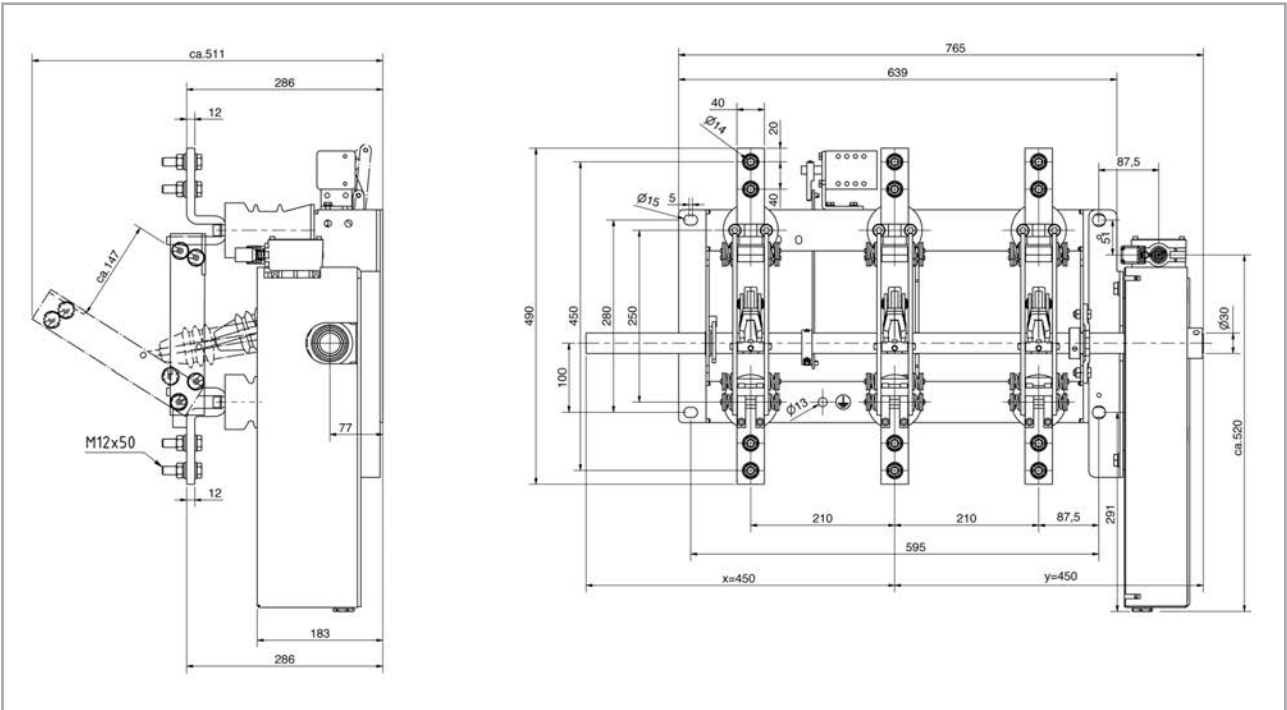

Diagram for ITr 12-1600-40 / Diagram number 116715



DRIESCHER – 3-pole indoor disconnecter

ITr 12-...-... ; (Ur 12 kV, Ir 2500 A)

Diagram for ITr 12-2500-40 / Diagram number 100813

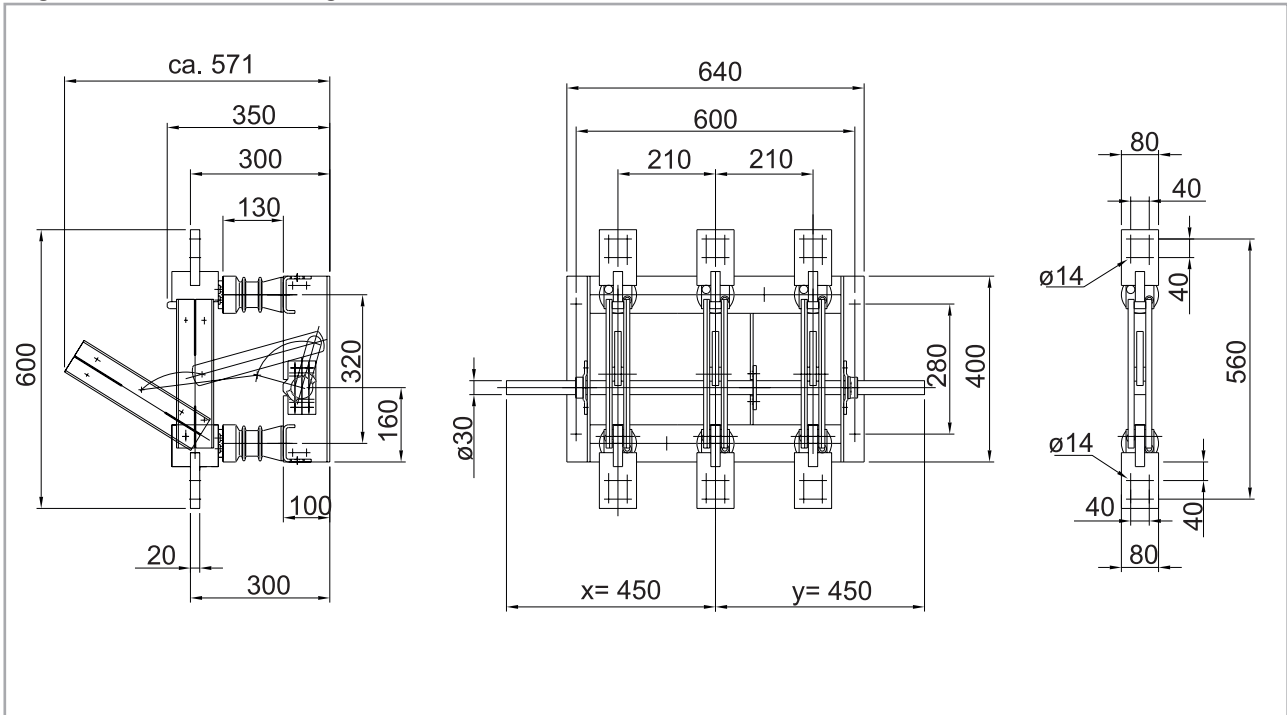
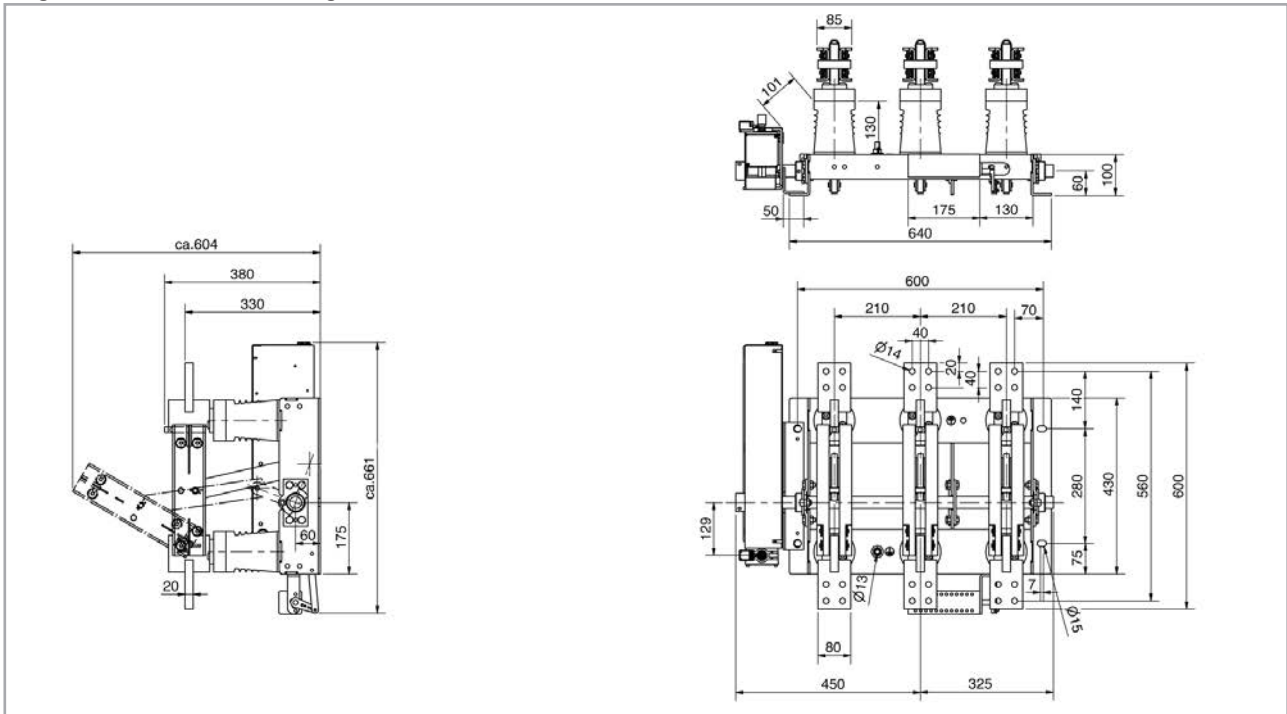

Diagram for ITr 12-2500-50 / Diagram number 116972



DRIESCHER – 3-pole indoor disconnecter

ITr 12-...-... ; (Ur 12 kV, Ir 4000 and 6300 A)

Diagram for ITr 12-4000-50 / Diagram number 103229

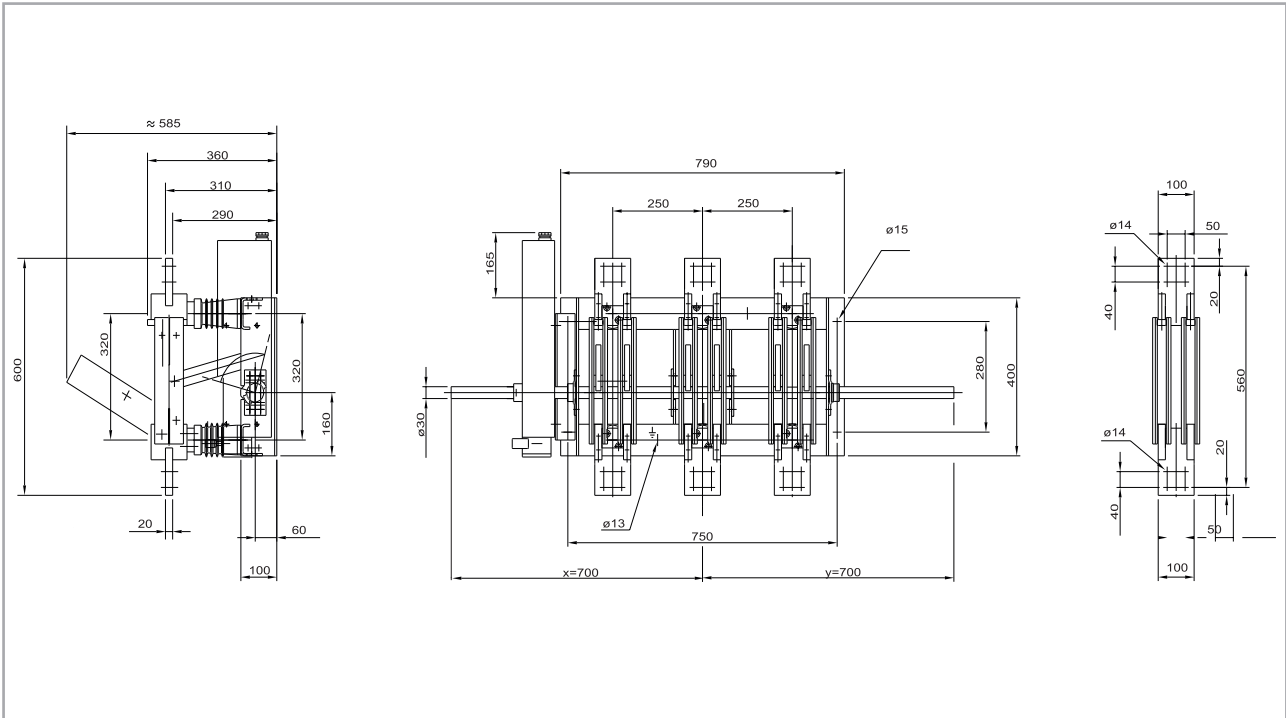
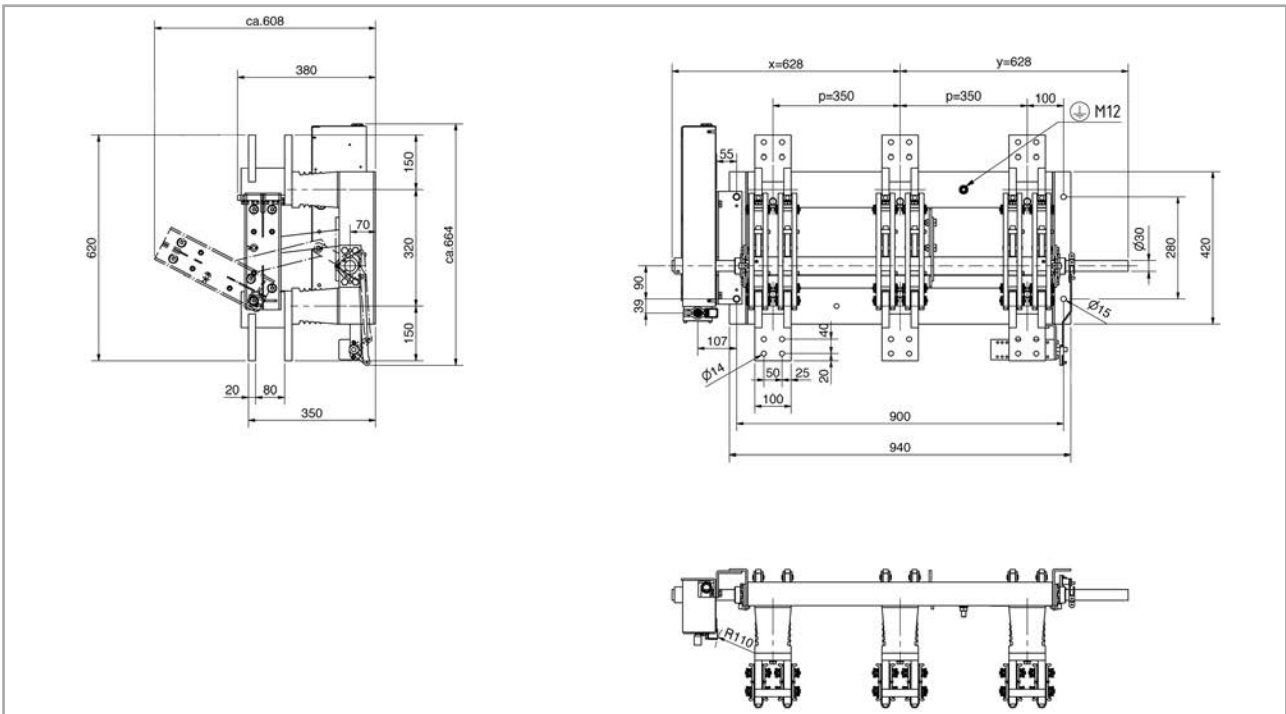

Diagram for ITr 12-6300-63 / Diagram number 110310



DRIESCHER – 3-pole indoor disconnecter

ITr 17,5-...-... ; (Ur 17,5 kV, Ir 4000 A and 6300 A)

Switch type		ITr 17,5-4000-50	ITr 17,5-4000-63	ITr 17,5-4000-72
Rated voltage	U_r	17,5 kV	17,5 kV	17,5 kV
Rated frequency	f_r	50/60 Hz	50/60 Hz	50/60 Hz
Rated current	I_r	4000 A	4000 A	4000 A
Rated short-time withstand current	I_k	50 kA	63 kA	72 kA
Rated short-circuit duration	t_k	3 s	1s / 3s	1s / 3s
Rated peak withstand current	I_p	137 kA	173 kA	198 kA
Rated lightning impulse withstand voltage	U_p			
- phase to earth		95 kV	95 kV	95 kV
- via the isolating distance		110 kV	110 kV	110 kV
Rated power frequency withstand voltage	U_d			
- phase to earth		38 kV	38 kV	38 kV
- via the isolating distance		45 kV	45 kV	45 kV
Mechanical service life		M1	M1	M1
Phase spacing p, mm		275	275	350
Motor drive		standard UM10	standard UM10	standard UM10
Weight (approx.)		100 kg	100 kg	105 kg
Diagram number for disconnectors with upright connections		115475	115807	117987
Diagram number for disconnectors with flat connections		115664	115808	118140
Diagram number for disconnector/earthing combination		117988	117500	on request

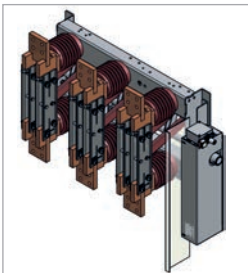

Fig.: ITr 17,5-4000-63
with flat connection

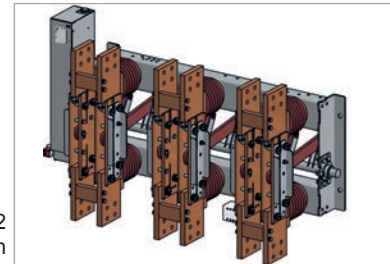

Fig.: ITr 17,5-6300-72
with upright connection

Switch type		ITr 17,5-6300-50	ITr 17,5-6300-63	ITr 17,5-6300-72	ITr 17,5-6300-80
Rated voltage	U_r	17,5 kV	17,5 kV	17,5 kV	17,5 kV
Rated frequency	f_r	50/60 Hz	50/60 Hz	50/60 Hz	50/60 Hz
Rated current	I_r	6300 A	6300 A	6300 A	6300 A
Rated short-time withstand current	I_k	50 kA	63 kA	72 kA	80 kA
Rated short-circuit duration	t_k	1s / 3s	1s / 3s	1 s	1 s
Rated peak withstand current	I_p	137 kA	173 kA	197 kA	208 kA
Rated lightning impulse withstand voltage	U_p				
- phase to earth		95 kV	95 kV	95 kV	95 kV
- via the isolating distance		110 kV	110 kV	110 kV	110 kV
Rated power frequency withstand voltage	U_d				
- phase to earth		38 kV	38 kV	38 kV	38 kV
- via the isolating distance		45 kV	45 kV	45 kV	45 kV
Mechanical service life		M1	M1	M1	M1
Phase spacing p, mm					
Motor drive		standard UM10	standard UM10	standard UM10	standard UM10
Weight (approx.)		115 kg	120 kg	125 kg	125 kg
Diagram no. for disconnectors with upright connections		115809	115678	117949	117956
Diagram no. for disconnectors with flat connections		on request	on request	on request	on request
Diagram no. for disconnector/earthing combination		117482	115790	on request	on request

DRIESCHER – 3-pole indoor disconnector

ITr 17,5-...-... ; (Ur 17,5 kV, Ir 4000 A)

Diagram for ITr 17,5-4000-50 flat connection / Diagram number 115664

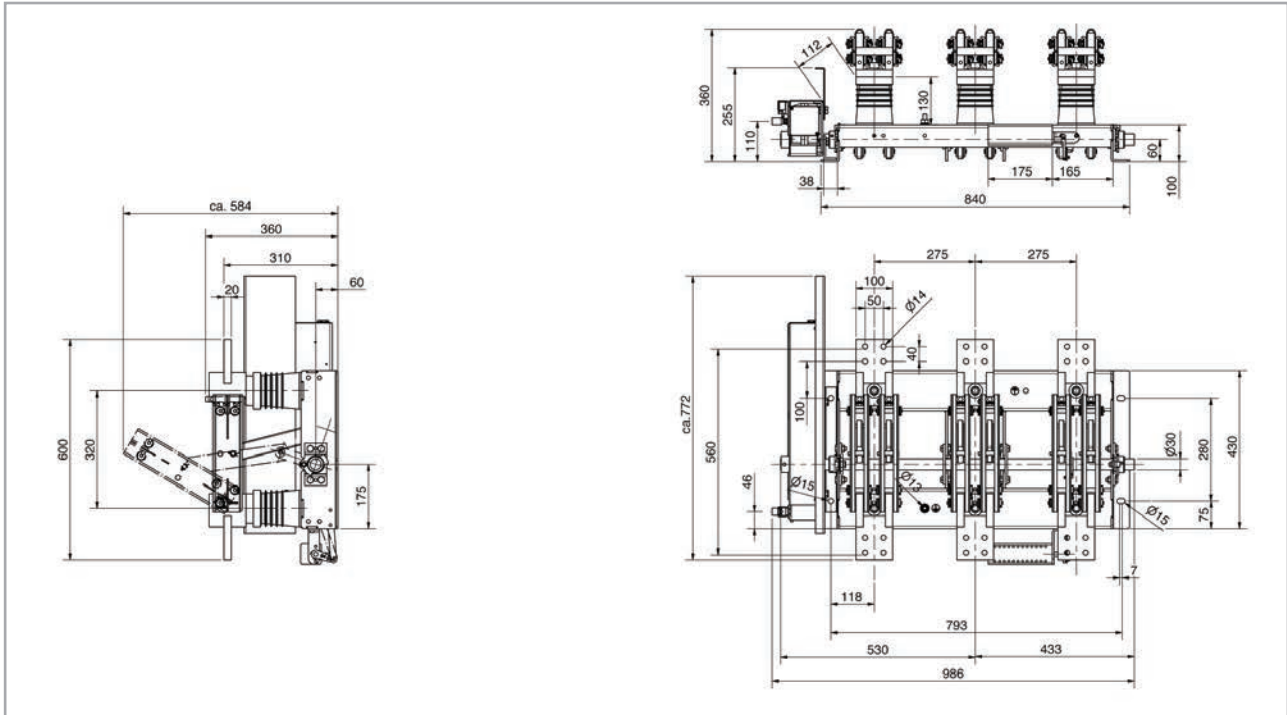
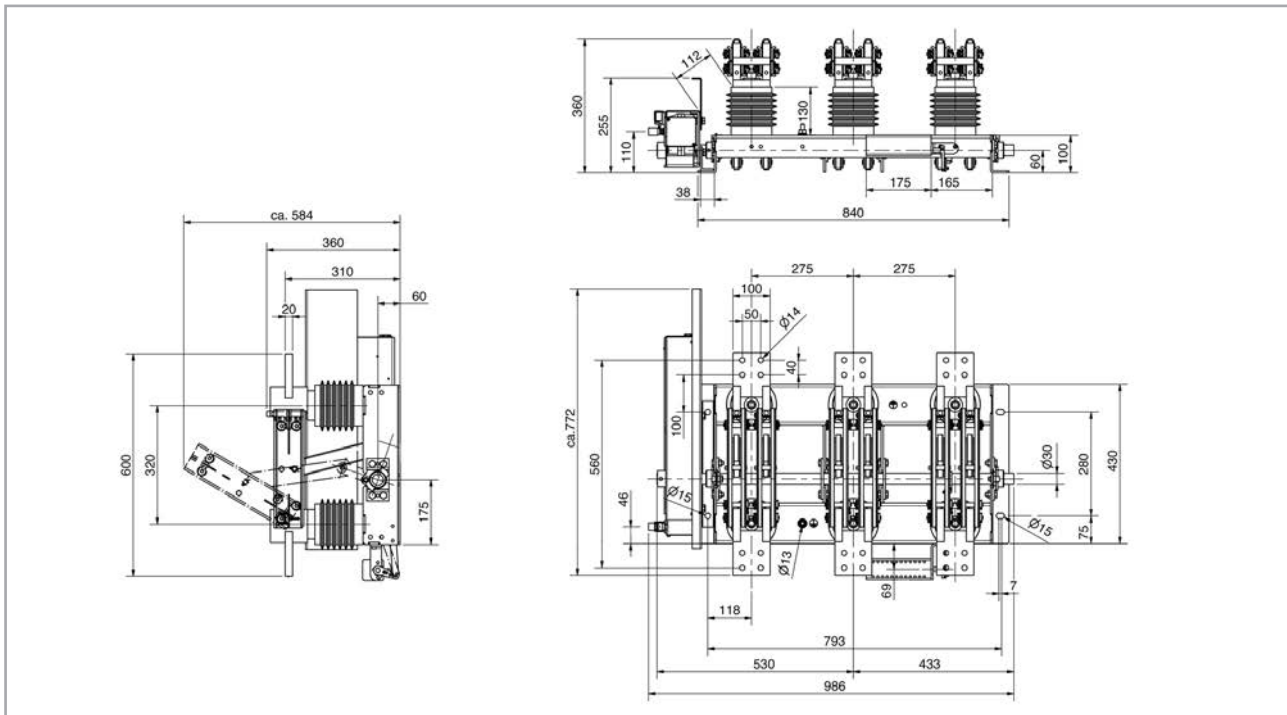

Diagram for ITr 17,5-4000-63 flat connection / Diagram number 115808



DRIESCHER – 3-pole indoor disconnecter

ITr 17,5-...-... ; (Ur 17,5 kV, Ir 4000 A and 6300 A)

Diagram for ITr 17,5-4000-72 flat connection / Diagram number 118140

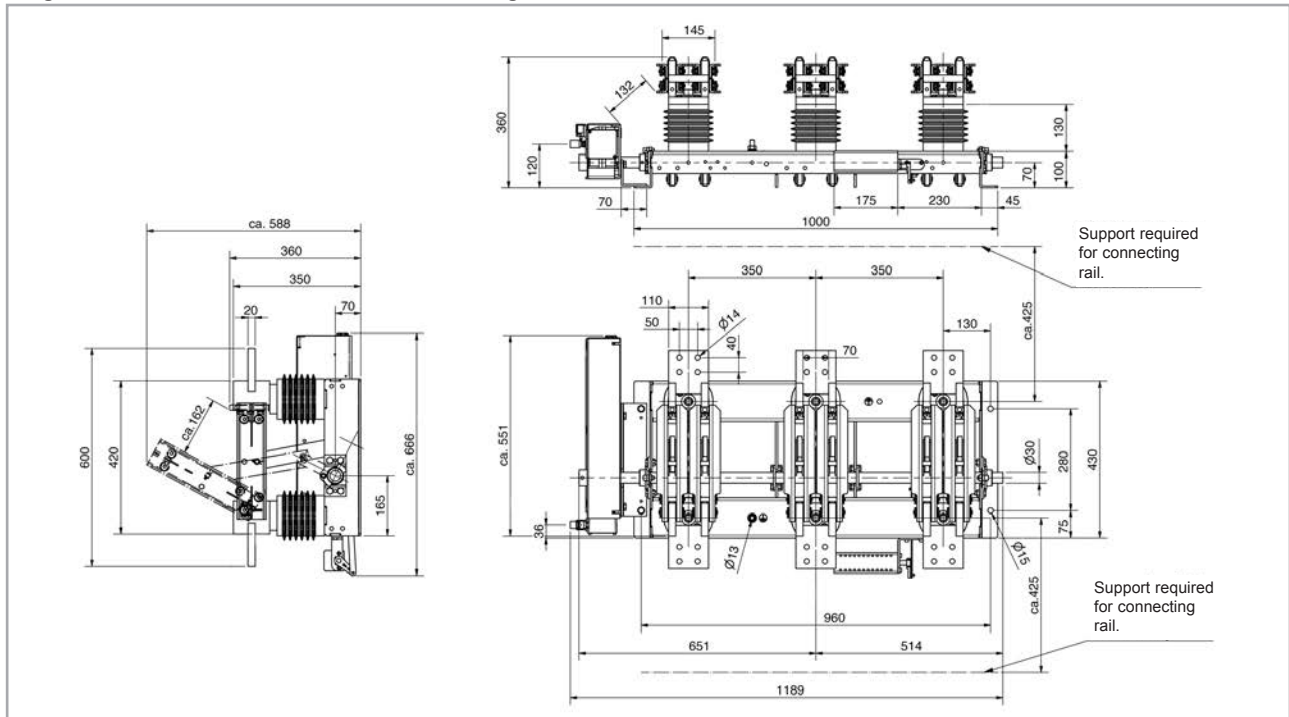
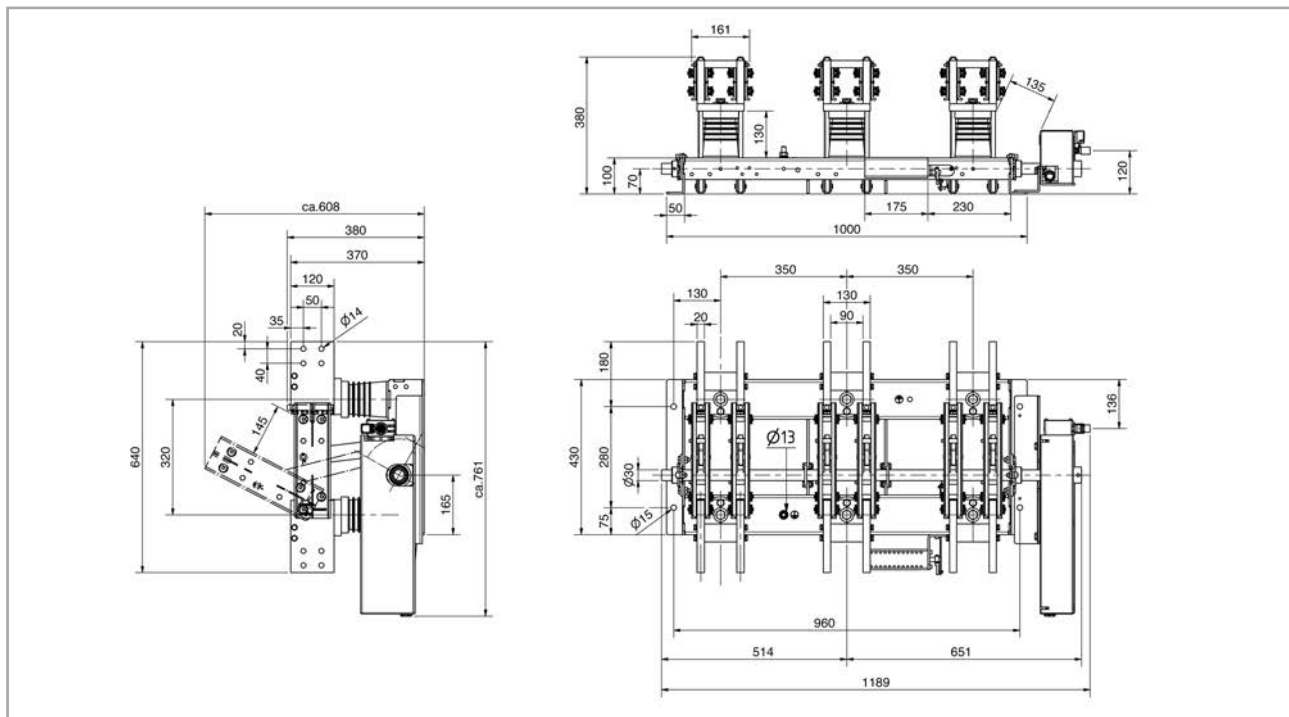

Diagram for ITr 17,5-6300-50 upright connection / Diagram number 115809



DRIESCHER – 3-pole indoor disconnecter

ITr 17,5-...-... ; (Ur 17,5 kV, Ir 6300 A)

Diagram for ITr 17,5-6300-63 upright connection / Diagram number 115678

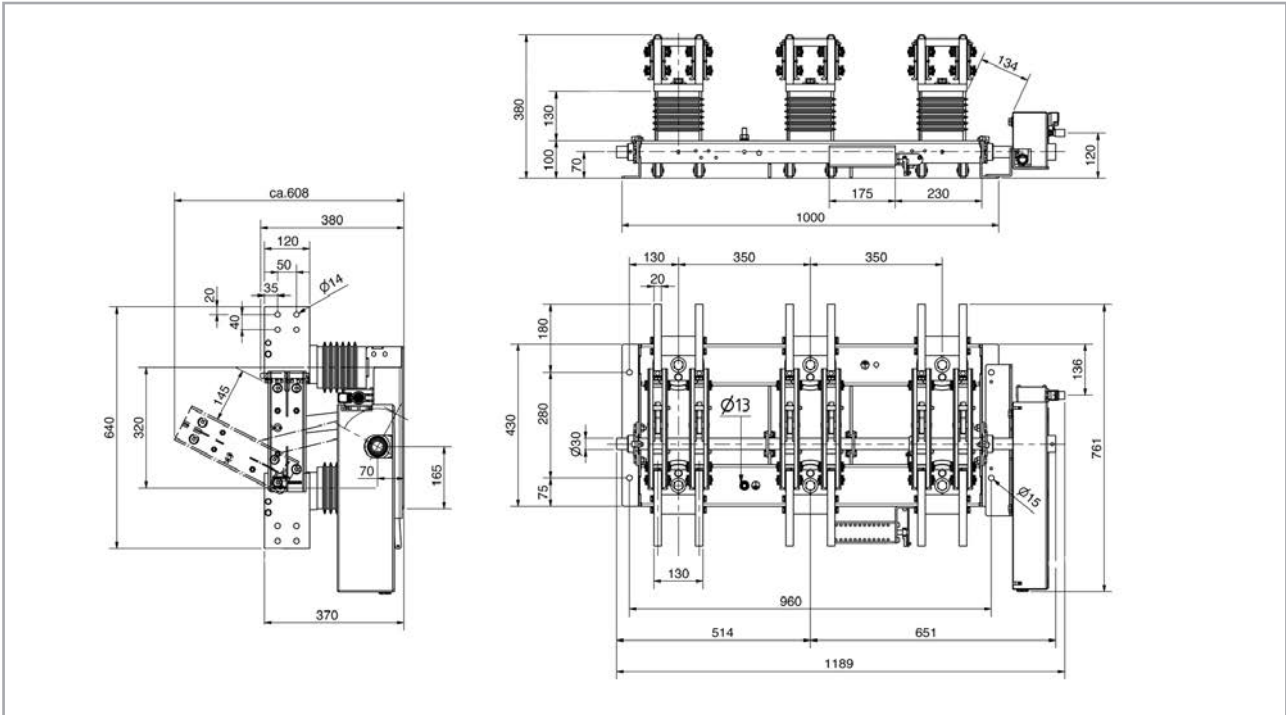
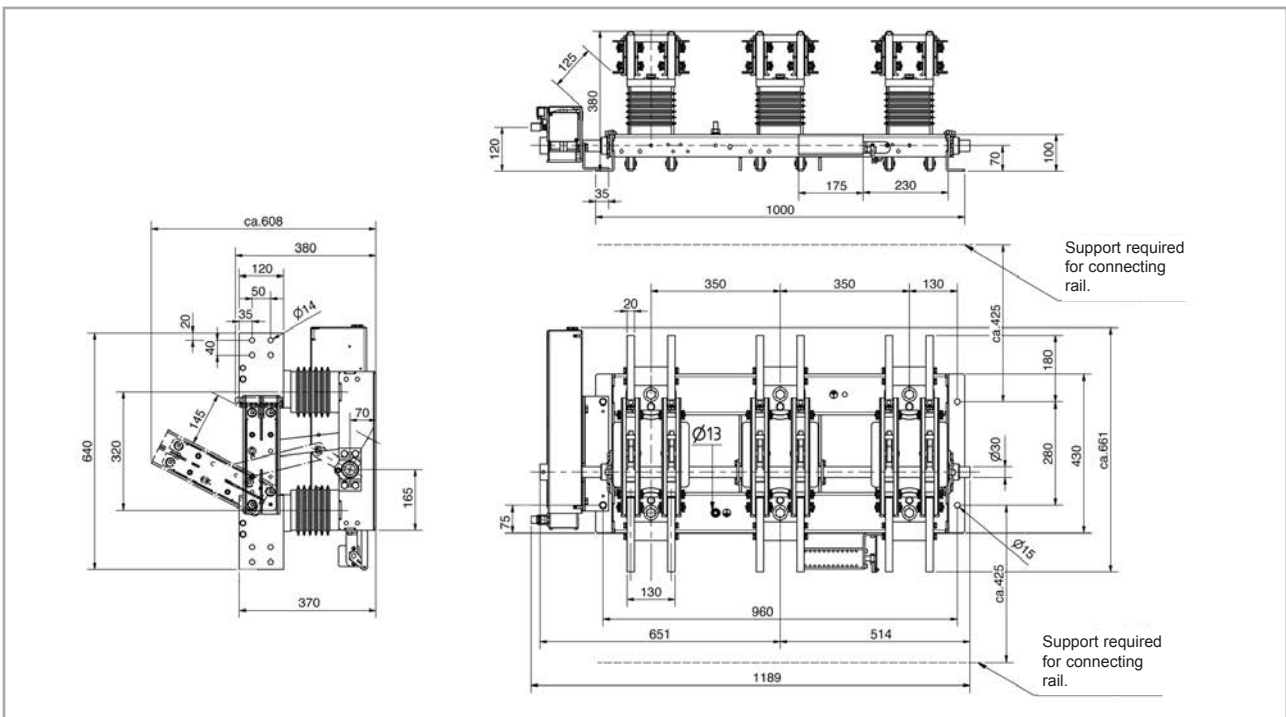

Diagram for ITr 17,5-6300-72 upright connection / Diagram number 117949



DRIESCHER – 3-pole indoor disconnecter

ITr 17.5-...-... ; (Ur 17.5 kV, Ir 6300 A)

Diagram for ITr 17.5-6300-80 upright connection / Diagram number 117956

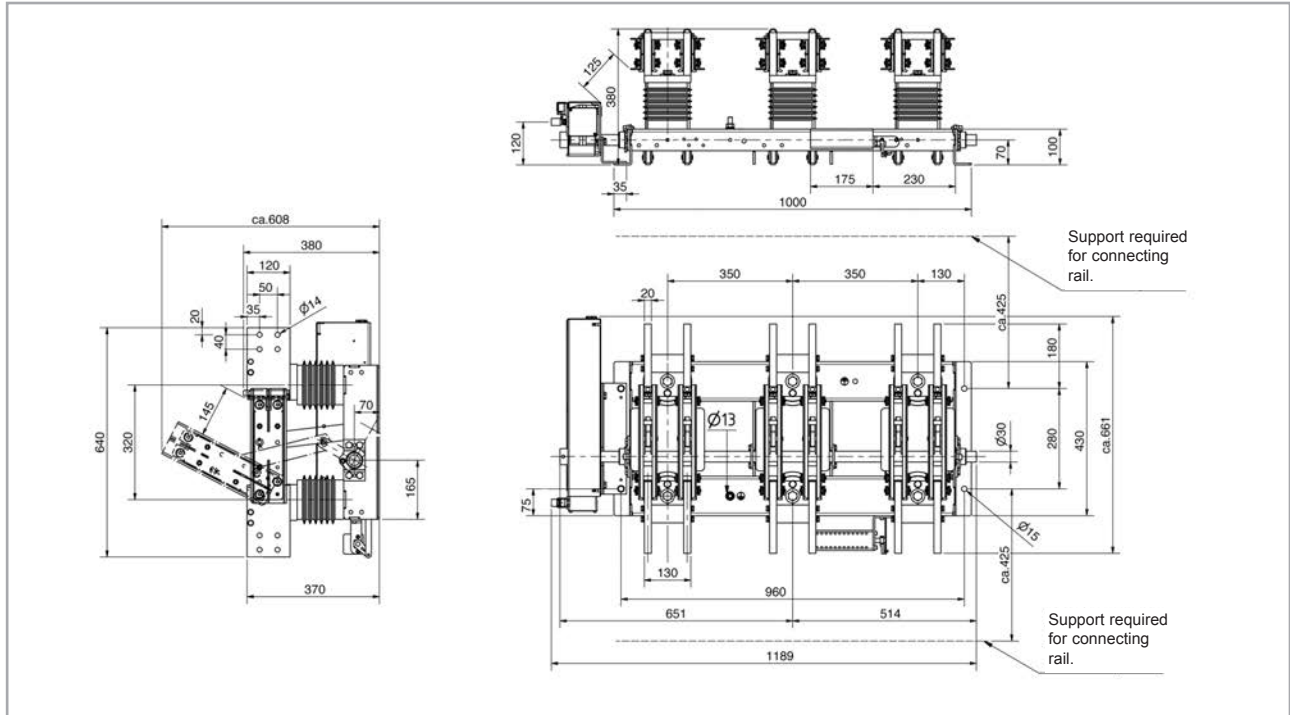

DRIESCHER – 3-pole indoor disconnecter

ITr 24-...-... ; (Ur 24 kV, Ir 630 - 6300 A) with flat connection

Switch type		ITr 24-630-20	ITr 24-800-25	ITr 24-1600-31,5	ITr 24-1600-40
Rated voltage	U_r	24 kV	24 kV	24 kV	24 kV
Rated frequency	f_r	50/60 Hz	50/60 Hz	50/60 Hz	50/60 Hz
Rated current	I_r	630 A	800 A	1600 A	1600 A
Rated short-time withstand current	I_k	20 kA	25 kA	31,5 kA	40 kA
Rated short-circuit duration	t_k	3 s	1 s	3 s	1 s
Rated peak withstand current	I_p	50 kA	63 kA	80 kA	100 kA
Rated lightning impulse withstand voltage	U_p				
- phase to earth		125 kV	125 kV	125 kV	125 kV
- via the isolating distance		145 kV	145 kV	145 kV	145 kV
Rated power frequency withstand voltage	U_d				
- phase to earth		50 kV	50 kV	50 kV	50 kV
- via the isolating distance		60 kV	60 kV	60 kV	60 kV
Mechanical service life		M2	M2	M2	M2
Motor drive		Optional	Optional	Optional	Optional
Optional Earthing switch		ES 24-20	ES 24-31,5	ES 24-31,5	ES 24-31,5
Weight (approx.)		31 kg	35 kg	50 kg	55 kg
Diagram number for disconnectors with flat connections		099825	112623	099847	112624
Phase spacing p, mm		245/275	275	275	275

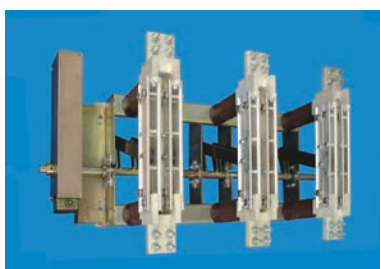

Fig.: ITr 24-4000-50

Accessories:

- Motor drive (UM10 and UM50)
- Auxiliary switch and earthing switch
- Mechanical interlocking device



Fig.: ITr 24-630-20

Switch type		ITr 24-2500-40	ITr 24-2500-50	ITr 24-4000-50	ITr 24-6300-63
Rated voltage	U_r	24 kV	24 kV	24 kV	24 kV
Rated frequency	f_r	50/60 Hz	50/60 Hz	50/60 Hz	50/60 Hz
Rated current	I_r	2500 A	2500 A	4000 A	6300 A
Rated short-time withstand current	I_k	40 kA	50 kA	50 kA	63 kA
Rated short-circuit duration	t_k	3 s	3 s	3 s	1s / 3s
Rated peak withstand current	I_p	100 kA	125 kA	125 kA	160 kA
Rated lightning impulse withstand voltage	U_p				
- phase to earth		125 kV	125 kV	125 kV	125 kV
- via the isolating distance		145 kV	145 kV	145 kV	145 kV
Rated power frequency withstand voltage	U_d				
- phase to earth		50 kV	50 kV	50 kV	50 kV
- via the isolating distance		60 kV	60 kV	60 kV	60 kV
Mechanical service life		M1	M1	M1	M1
Motor drive		Optional	Optional	standard UM10	standard UM10
Optional Earthing switch		ES 24-31,5	ES 24-31,5	ES 24-31,5	ES 24-31,5
Weight (approx.)		75 kg	85 kg	142 kg	210 kg
Diagram number for disconnectors with flat connections		100812	117088	115630	117673
Phase spacing p, mm		275	275	400	350

DRIESCHER – 3-pole indoor disconnecter

ITr 24-...-... ; (Ur 24 kV, Ir 630 and 800 A) with flat connection

Diagram for ITr 24-630-20 / Diagram number 099825

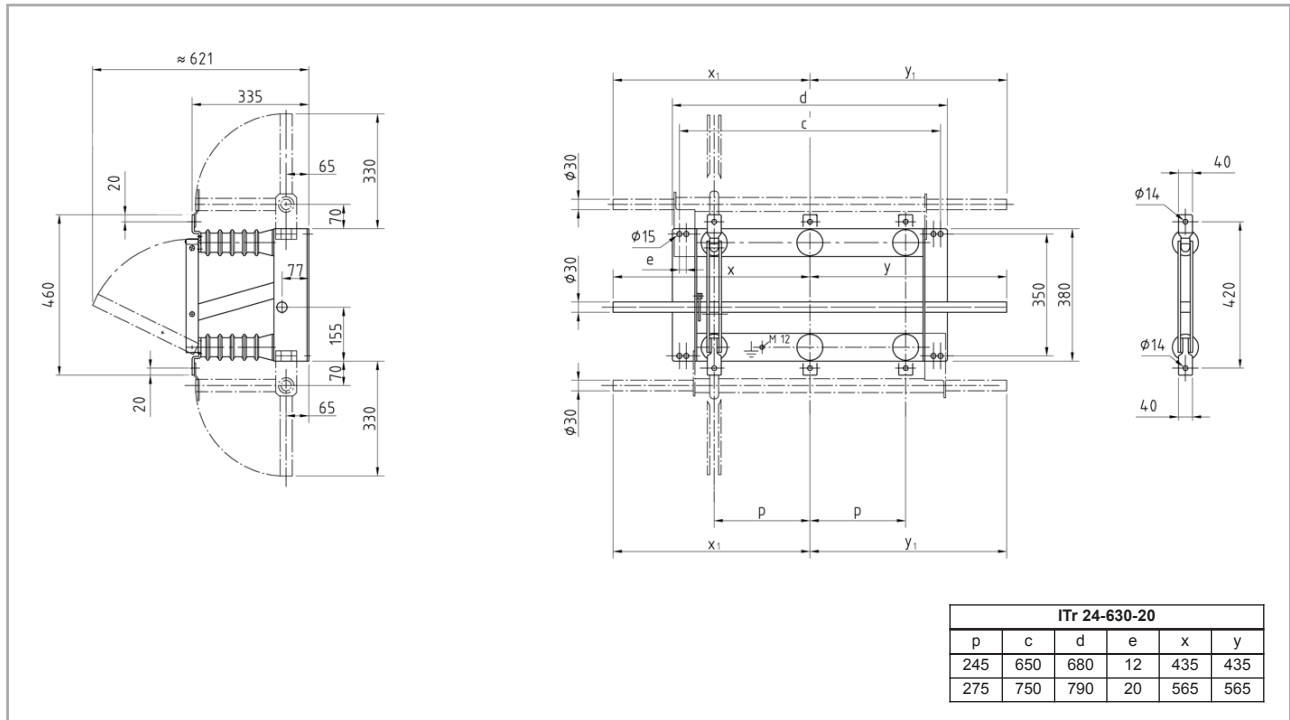
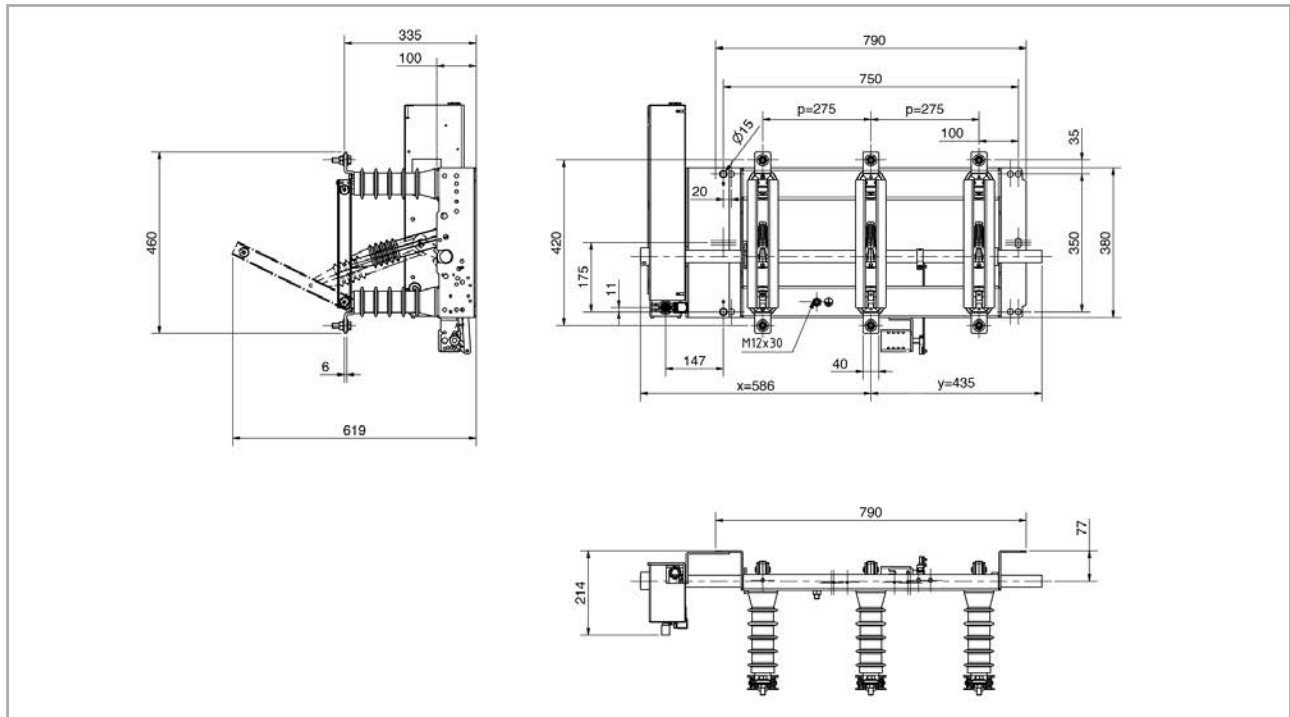

Diagram for ITr 24-800-25 / Diagram number 112623



DRIESCHER – 3-pole indoor disconnecter

ITr 24-...-... ; (Ur 24 kV, Ir 1600 A) with flat connection

Diagram for ITr 24-1600-31,5 / Diagram number 099847

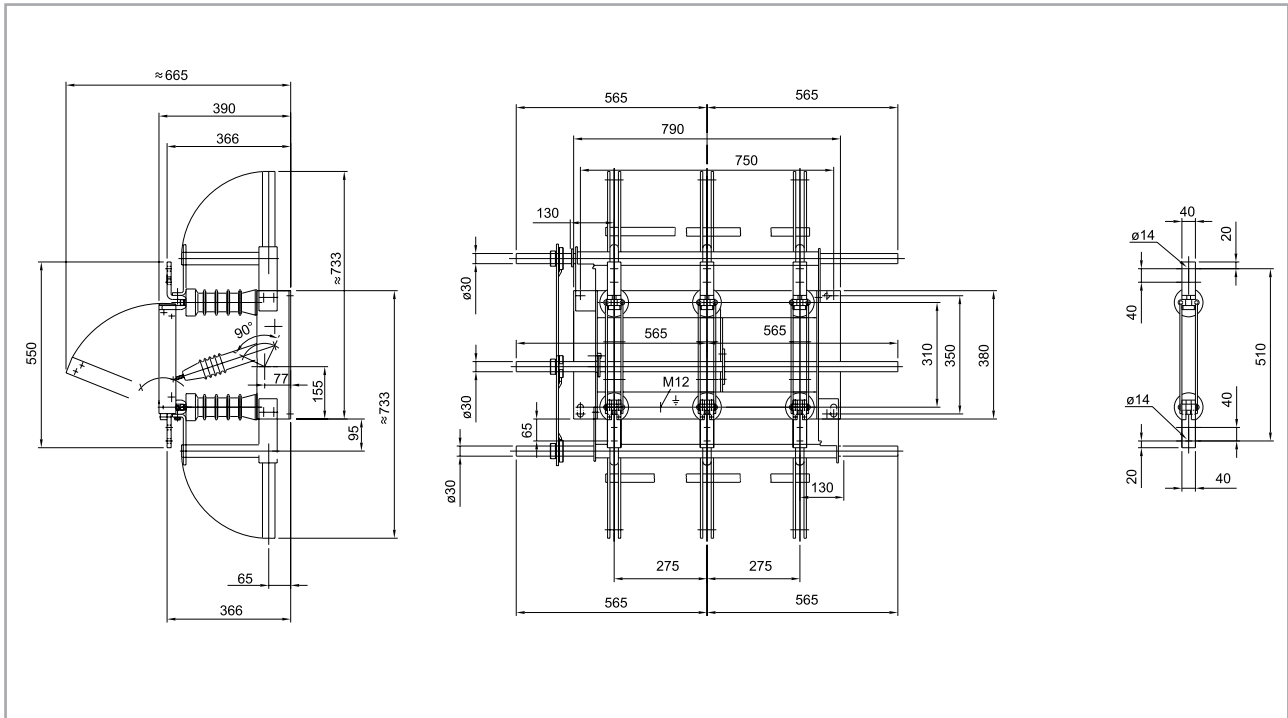
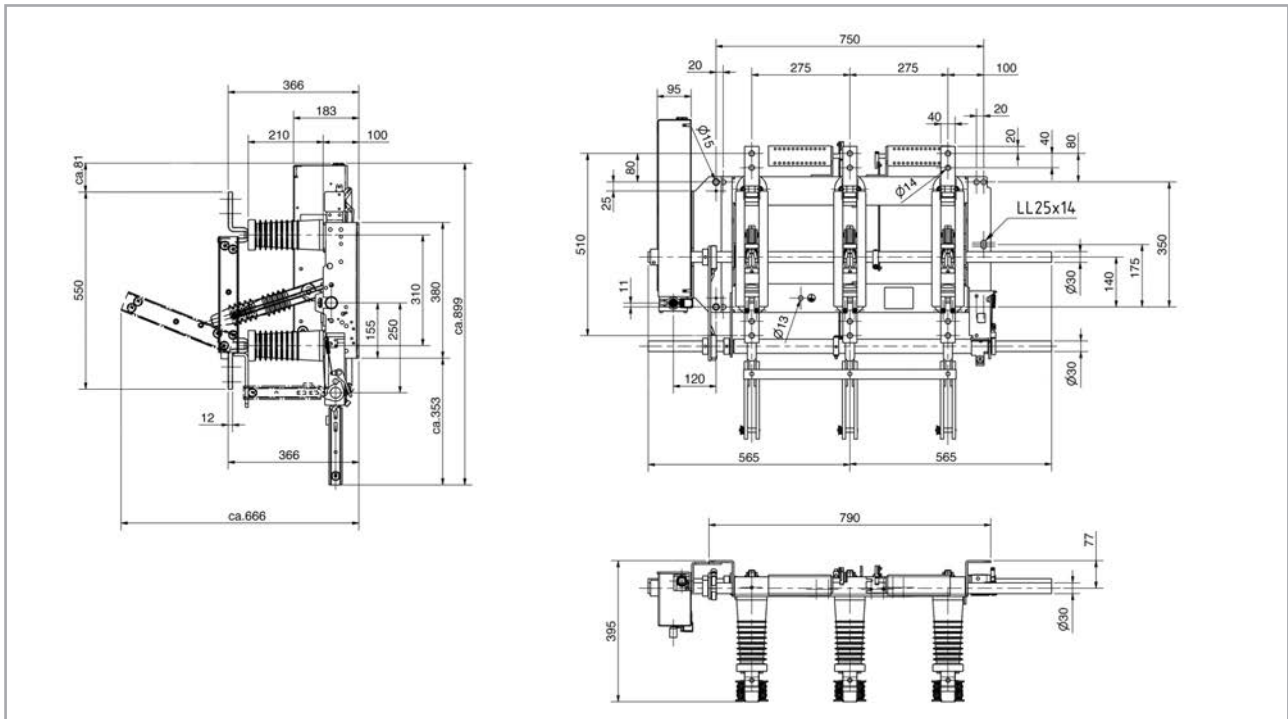

Diagram for ITr 24-1600-40 / Diagram number 112624



DRIESCHER – 3-pole indoor disconnecter

ITr 24-...-... ; (Ur 24 kV, Ir 2500 A) with flat connection

Diagram for ITr 24-2500-40 / Diagram number 100812

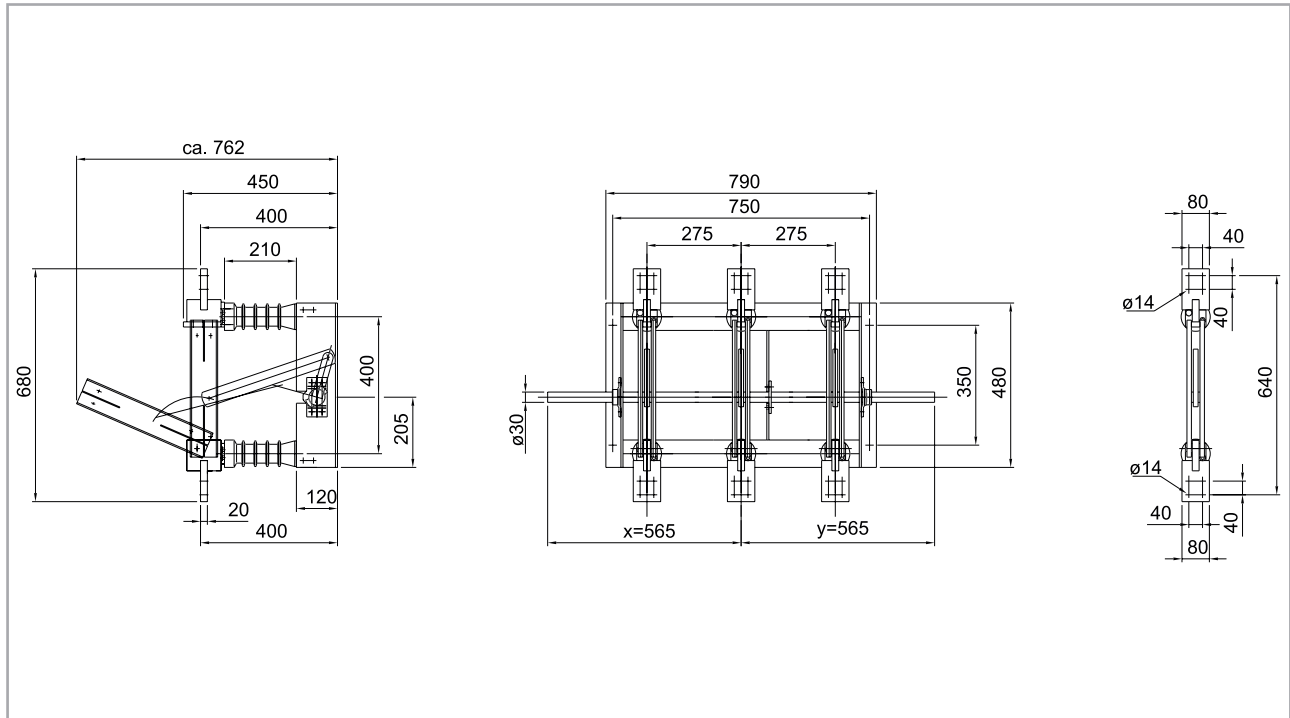
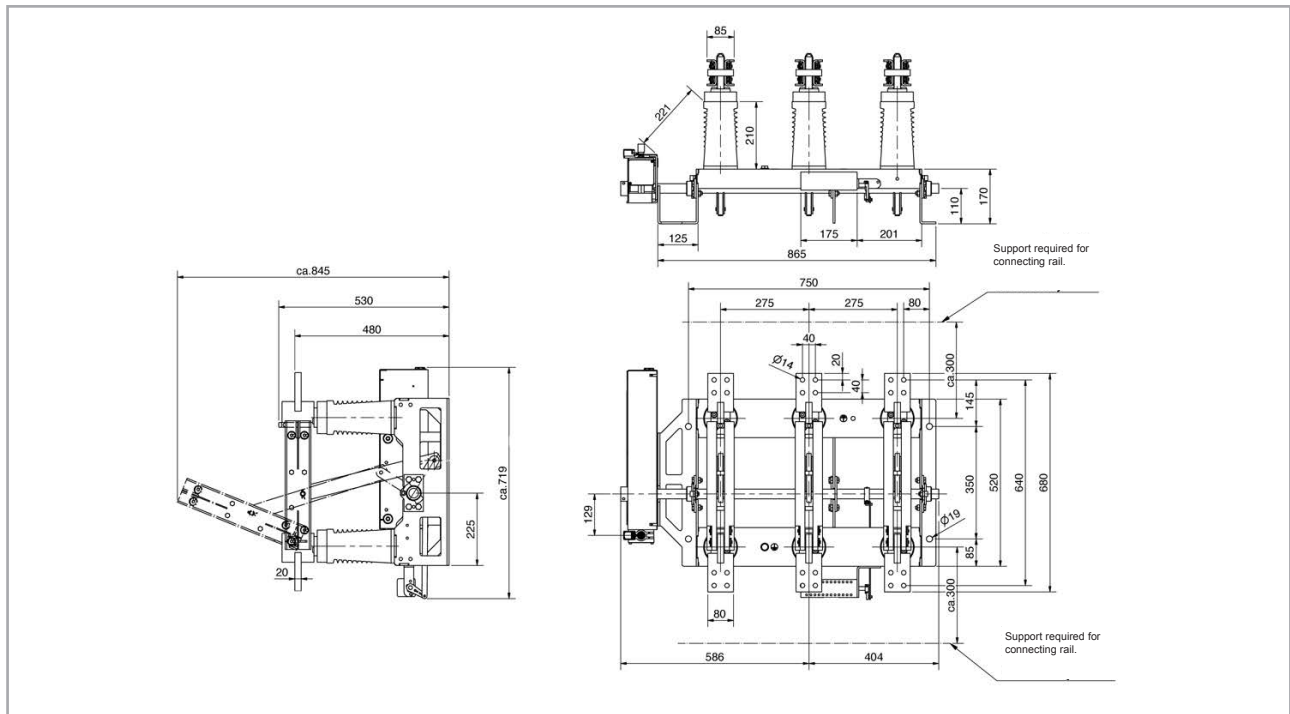

Diagram for ITr 24-2500-50 / Diagram number 117088



DRIESCHER – 3-pole indoor disconnecter

ITr 24-...-... ; (Ur 24 kV, Ir 4000 and 6300 A) with flat connection

Diagram for ITr 24-4000-50 / Diagram number 115630

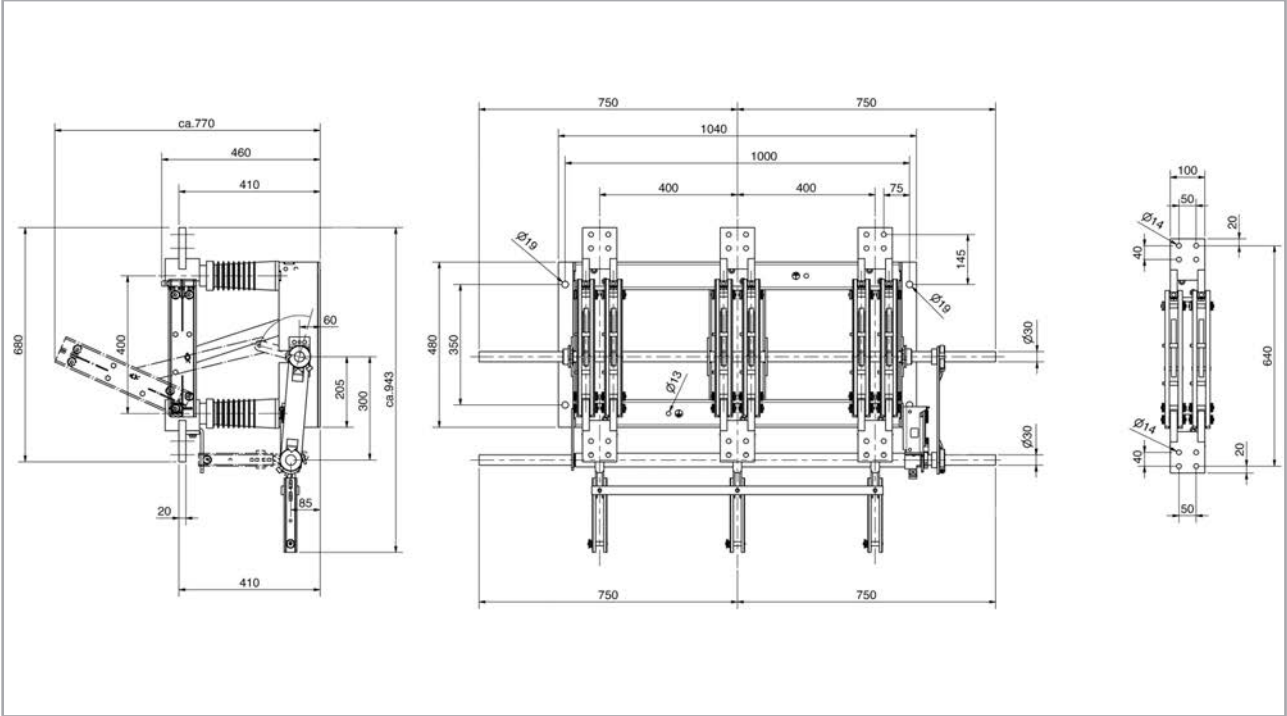
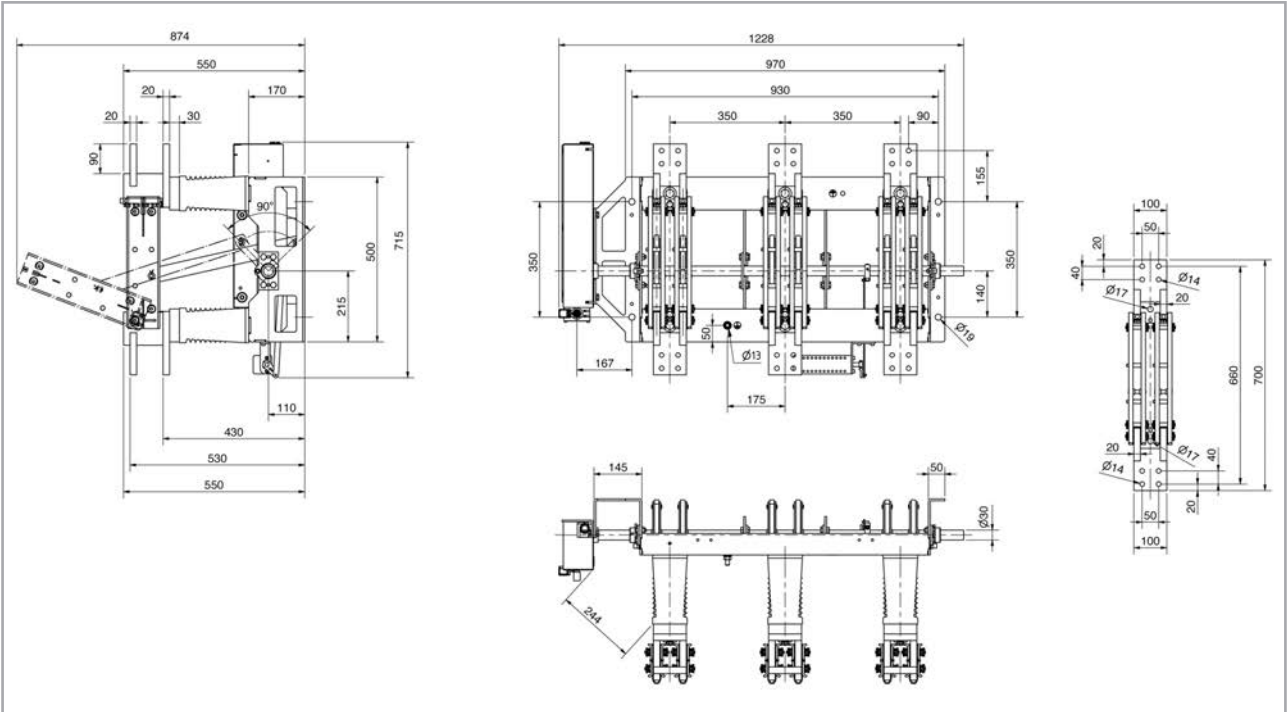

Diagram for ITr 24-6300-63 / Diagram number 117673



DRIESCHER – 3-pole indoor disconnecter

ITr 24-...-... ; (Ur 24 kV, Ir 4000 A and 6300 A) with upright connection

Switch type		ITr 24-4000-50	ITr 24-4000-63	ITr 24-4000-72
Rated voltage	U_r	24 kV	24 kV	24 kV
Rated frequency	f_r	50/60 Hz	50/60 Hz	50/60 Hz
Rated current	I_r	4000 A	4000 A	4000 A
Rated short-time withstand current	I_k	50 kA	63 kA	72 kA
Rated short-circuit duration	t_k	3 s	1 s / 3 s	1 s
Rated peak withstand current	I_p	137 kA	173 kA	198 kA
Rated lightning impulse withstand voltage	U_p			
- phase to earth		125 kV	125 kV	125 kV
- via the isolating distance		145 kV	145 kV	145 kV
Rated power frequency withstand voltage	U_d			
- phase to earth		50 kV	50 kV	50 kV
- via the isolating distance		60 kV	60 kV	60 kV
Mechanical service life		M1	M1	M1
Motor drive		standard UM10	standard UM10	standard UM10
Weight (approx.)		130 kg	150 kg	150 kg
Diagram number for disconnectors with upright connections		117196	117246	117948
Phase spacing p, mm		350	350	350

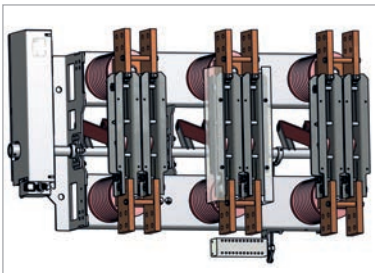

Fig.: ITr 24-4000-50
with upright connection

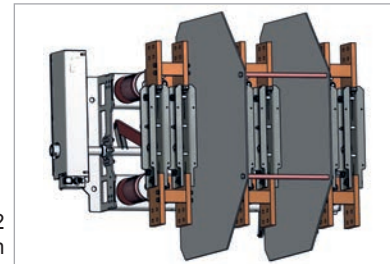

Fig.: ITr 24-6300-72
with upright connection

Switch type		ITr 24-6300-50	ITr 24-6300-63	ITr 24-6300-72
Rated voltage	U_r	24 kV	24 kV	24 kV
Rated frequency	f_r	50/60 Hz	50/60 Hz	50/60 Hz
Rated current	I_r	6300 A	6300 A	6300 A
Rated short-time withstand current	I_k	50 kA	63 kA	72 kA
Rated short-circuit duration	t_k	3 s	1 s / 3 s	1 s
Rated peak withstand current	I_p	137 kA	164 kA	197 kA
Rated lightning impulse withstand voltage	U_p			
- phase to earth		125 kV	125 kV	125 kV
- via the isolating distance		145 kV	145 kV	145 kV
Rated power frequency withstand voltage	U_d			
- phase to earth		50 kV	50 kV	50 kV
- via the isolating distance		60 kV	60 kV	60 kV
Mechanical service life		M1	M1	M1
Motor drive		standard UM10	standard UM10	standard UM10
Weight (approx.)		190 kg	230 kg	230 kg
Diagram number for disconnectors with upright connections		117958	117985	117986
Phase spacing p, mm		350	350	350

DRIESCHER – 3-pole indoor disconnecter

ITr 24-...-... ; (Ur 24 kV, Ir 4000 A) with upright connection

Diagram for ITr 24-4000-50 upright connection / Diagram number 117196

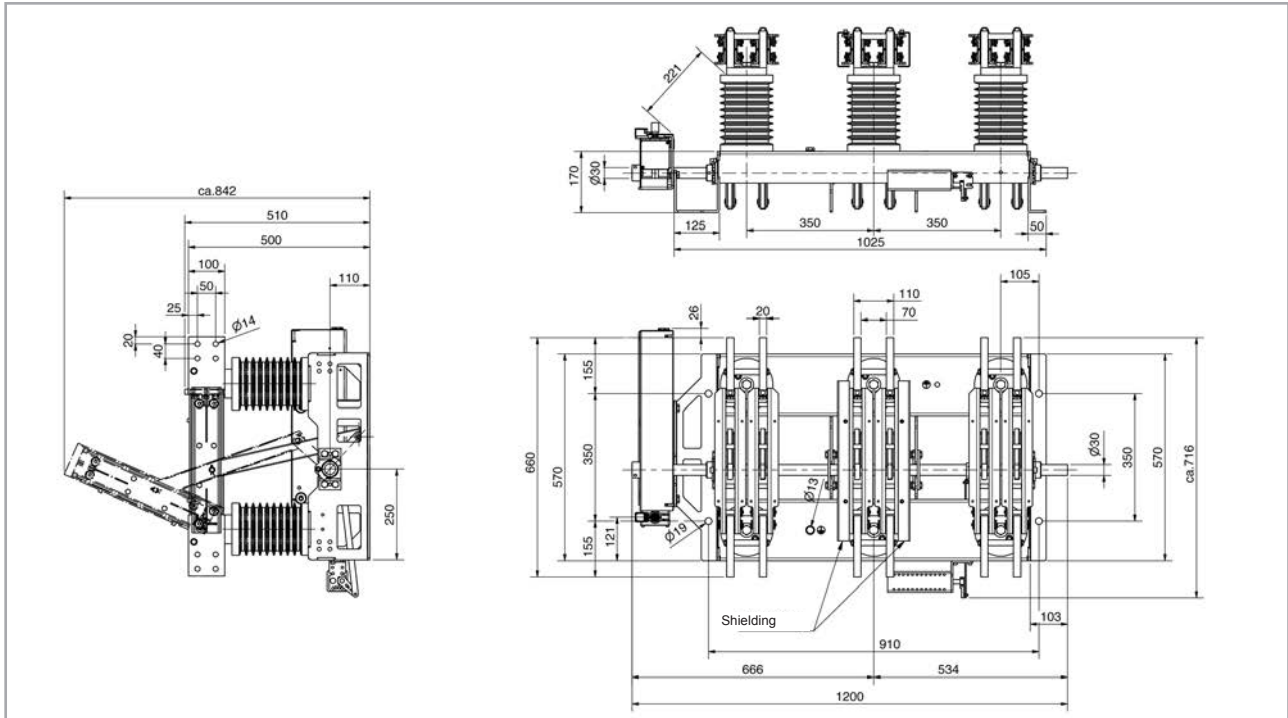
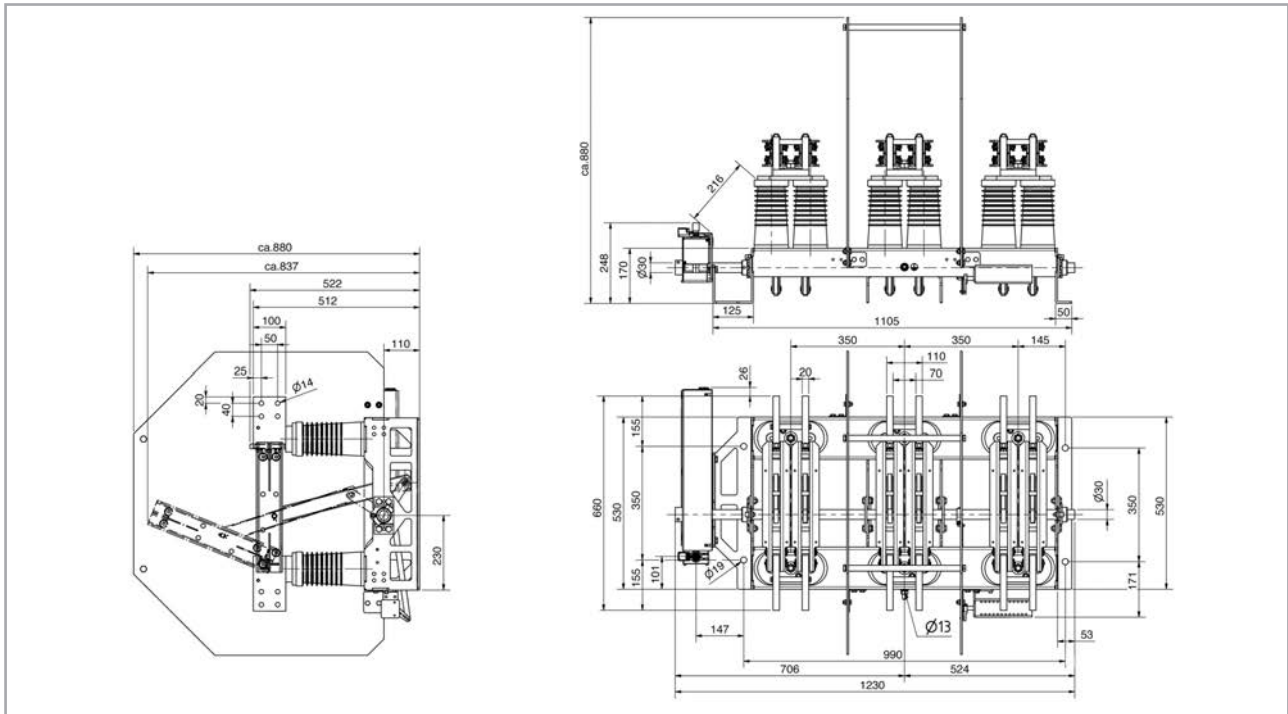

Diagram for ITr 24-4000-63 upright connection / Diagram number 117246



DRIESCHER – 3-pole indoor disconnecter

ITr 24-....-... ; (Ur 24 kV, Ir 4000 and 6300 A) with upright connection

Diagram for ITr 24-4000-72 upright connection / Diagram number 117948

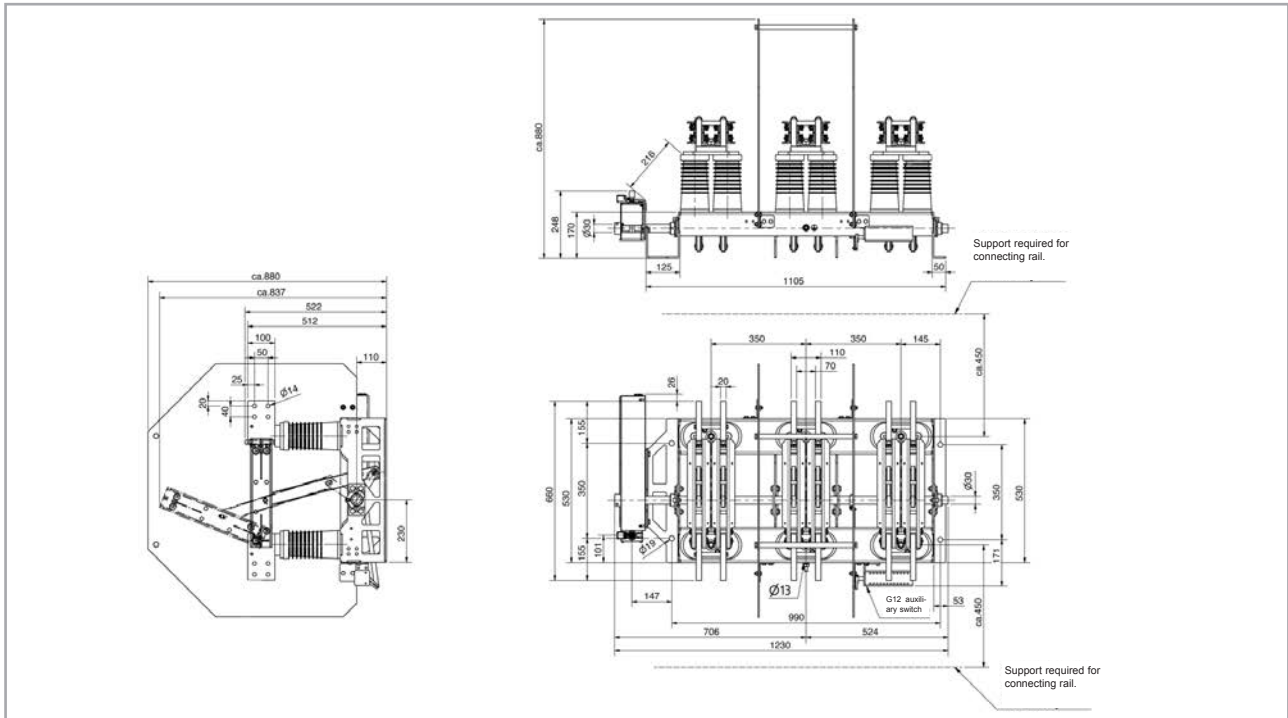
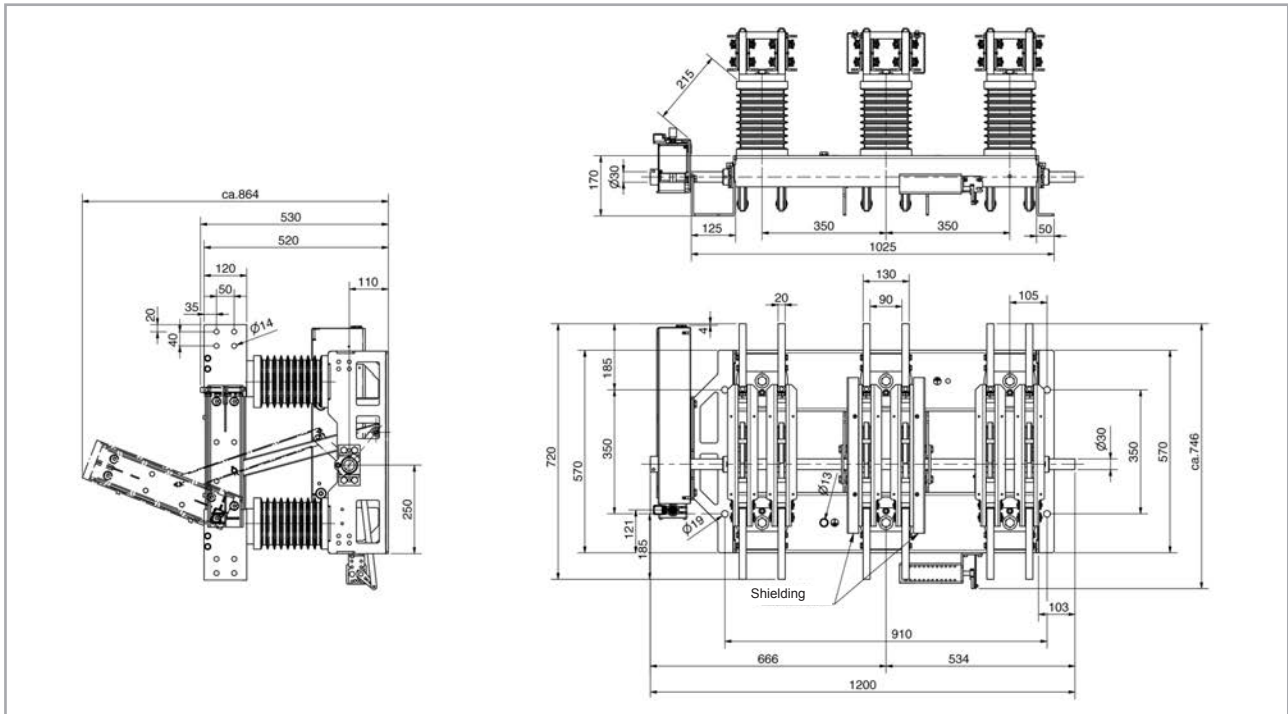

Diagram for ITr 24-6300-50 upright connection / Diagram number 117958



DRIESCHER – 3-pole indoor disconnecter

ITr 24-...-... ; (Ur 24 kV, Ir 6300 A) with upright connection

Diagram for ITr 24-6300-63 upright connection / Diagram number 117985

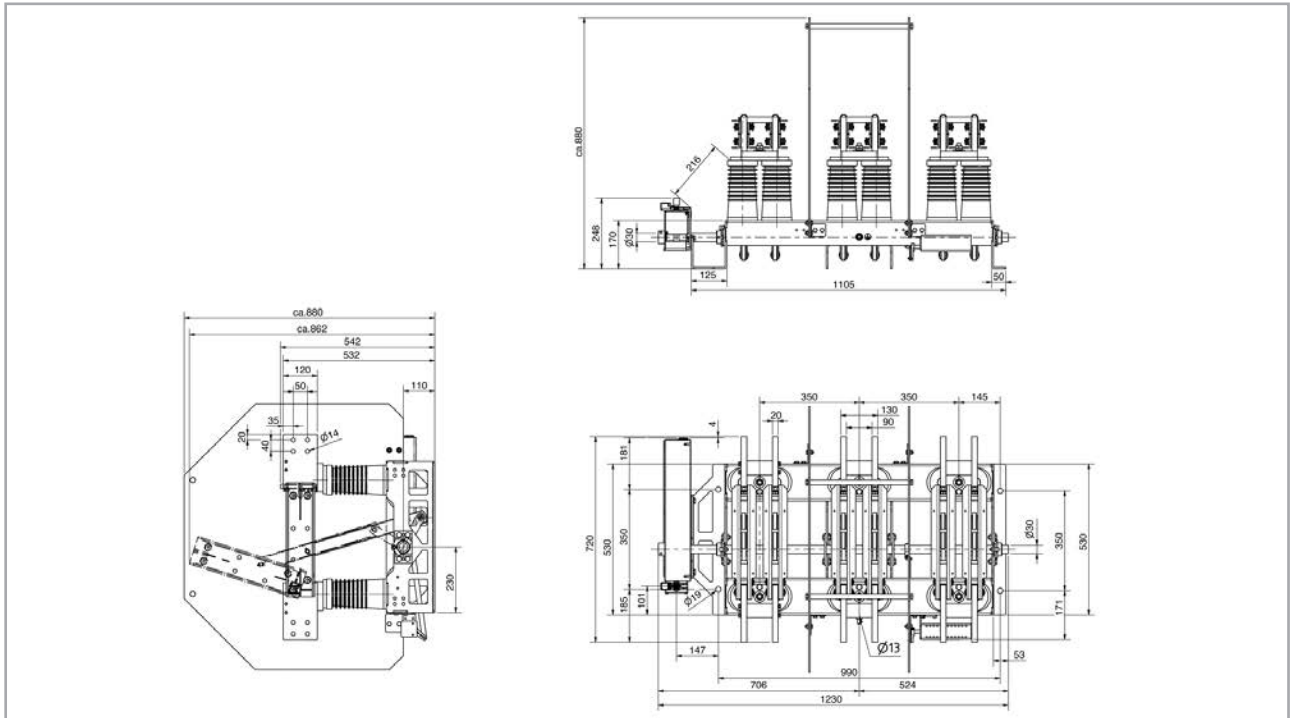
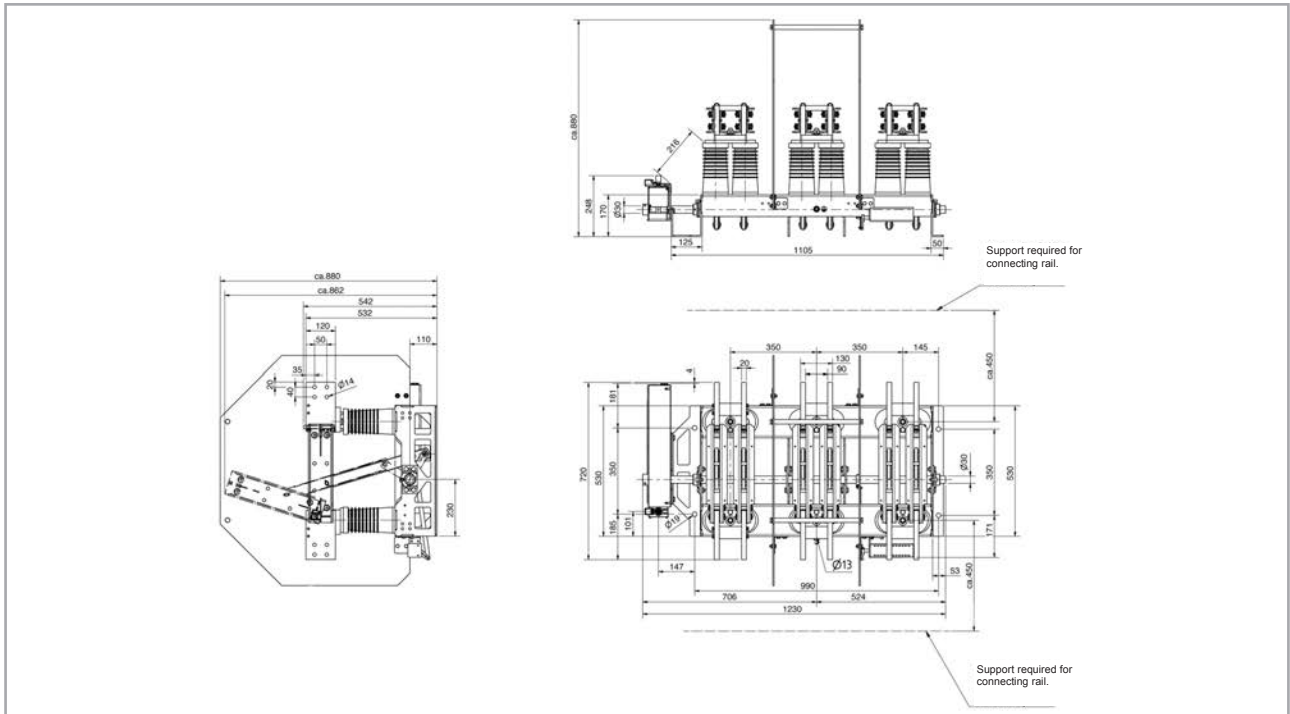

Diagram for ITr 24-6300-72 upright connection / Diagram number 117986



DRIESCHER – 3-pole indoor disconnecter

ITr 36-...-... ; (Ur 36 kV, Ir 630 - 4000 A)

Switch type		ITr 36-630-20	ITr 36-1600-40	ITr 36-2500-50	ITr 36-4000-50
Rated voltage	U_r	36 kV	36 kV	36 kV	36 kV
Rated frequency	f_r	50/60 Hz	50/60 Hz	50/60 Hz	50/60 Hz
Rated current	I_r	630 A	1600 A	2500 A	4000 A
Rated short-time withstand current	I_k	20 kA	40 kA	50 kA	50 kA
Rated short-circuit duration	t_k	3 s	3 s	3 s	3 s
Rated peak withstand current	I_p	50 kA	100 kA	125 kA	125 kA
Rated lightning impulse withstand voltage	U_p				
- phase to earth		170 kV	170 kV	170 kV	170 kV
- via the isolating distance		195 kV	195 kV	195 kV	195 kV
Rated power frequency withstand voltage	U_d				
- phase to earth		70 kV	70 kV	70 kV	70 kV
- via the isolating distance		80 kV	80 kV	80 kV	80 kV
Diagram number		099826	102811	101187	106246
Mechanical service life		M2	M2	M1	M1
Motor drive		Optional	Optional	Optional	standard UM10
Optional Earthing switch		ES 36-20	ES 36-31,5*	ES 36-31,5*	ES 36-31,5*
Weight (approx.)		40 kg	63 kg	105 kg	175 kg
Phase spacing p, mm		400	400	400	500

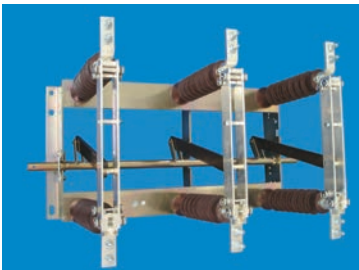
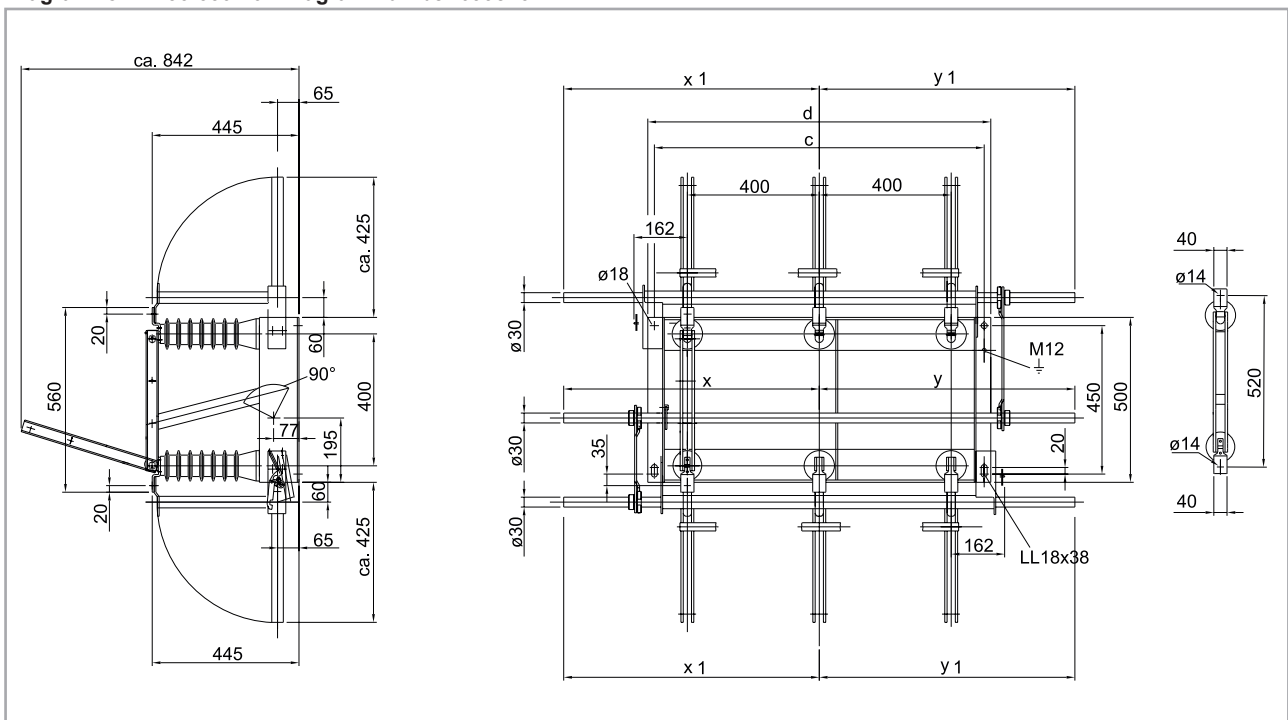

Fig.: ITr 36-1600-40

*Short-circuit making current I_{ma} restricted to 50 kA.

- Accessories:**
- Earthing switch
 - Mechanical interlocking device
 - Motor drive (UM 10 and UM 50)
 - Auxiliary switch

Diagram for ITr 36-630-20 / Diagram number 099826



DRIESCHER – 3-pole indoor disconnecter

ITr 36-...-... ; (Ur 36 kV, Ir 1600 A and 2500 A)

Diagram for ITr 36-1600-40 / Diagram number 102811

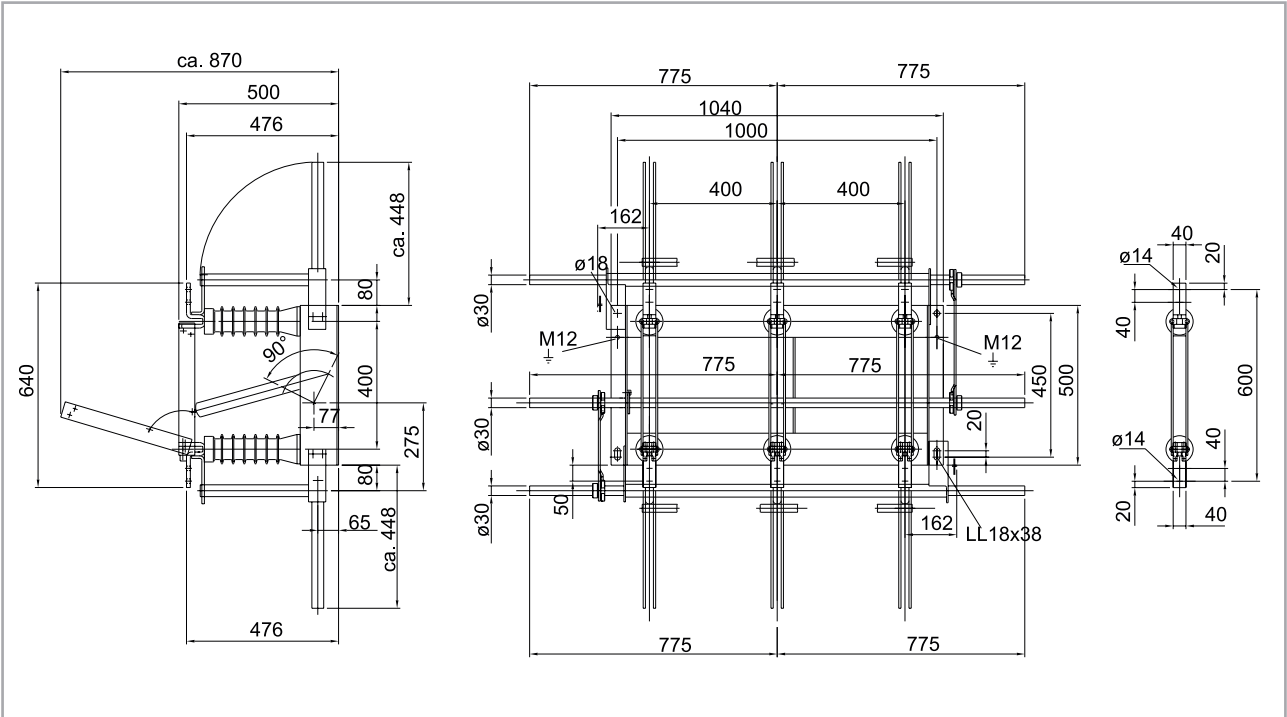
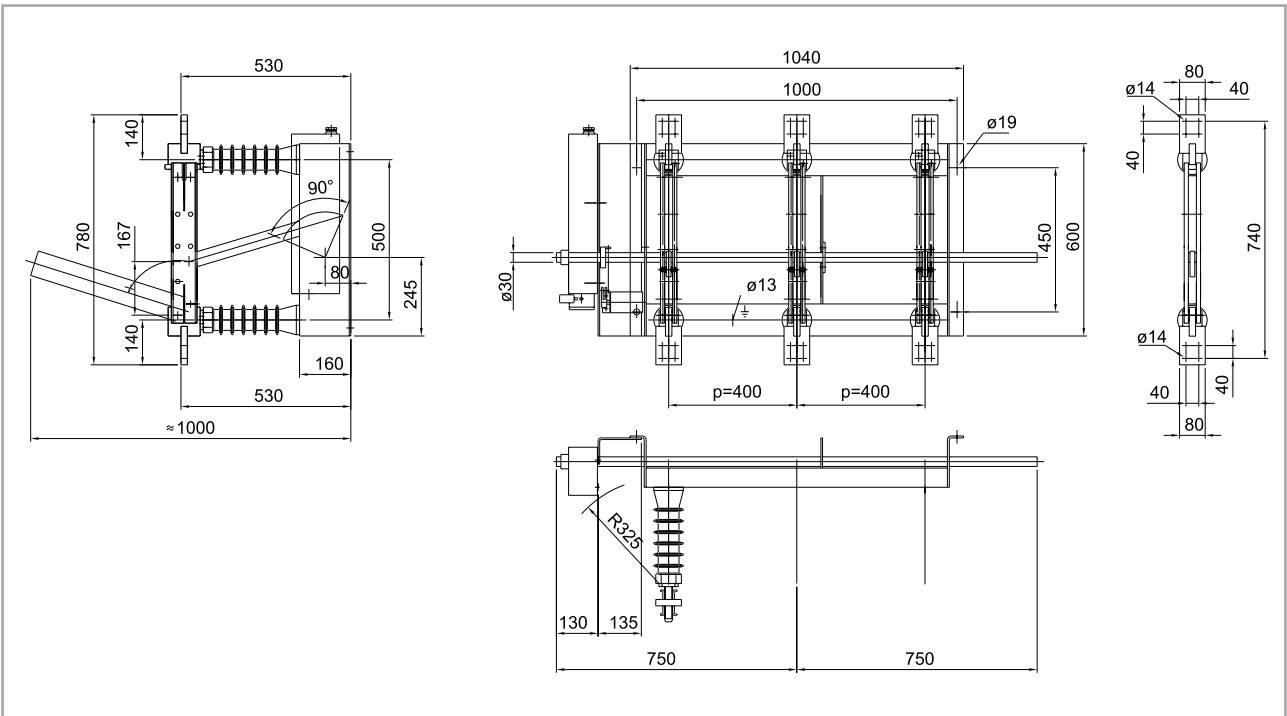

Diagram for ITr 36-2500-50 / Diagram number 101187



DRIESCHER – 3-pole indoor disconnecter

ITr 36/38,5-...-... ; (Ur 38,5 kV)

Switch type		ITr 38,5-630-20	ITr 38,5-1600-40	ITr 36-2500-50
Rated voltage	U_r	38,5 kV	38,5 kV	38,5 kV
Rated frequency	f_r	50 Hz	50 Hz	50 Hz
Rated current	I_r	630 A	1600 A	2500 A
Rated short-time withstand current	I_k	20 kA	40 kA	50 kA
Rated short-circuit duration	t_k	3 s	3 s	3 s
Rated peak withstand current	I_p	50 kA	100 kA	125 kA
Rated lightning impulse withstand voltage	U_p			
- phase to earth		180 kV	180 kV	180 kV
- via the isolating distance		210 kV	210 kV	210 kV
Rated power frequency withstand voltage	U_d			
- phase to earth		80 kV	80 kV	80 kV
- via the isolating distance		90 kV	90 kV	90 kV
Diagram number		099827	104596	110770
Mechanical service life		M2	M2	M2
Motor drive		Optional	Optional	Optional
Optional Earthing switch		ES 38,5-20	ES 38,5-31,5*	ES 38,5-31,5*
Weight (approx.)		43 kg	66 kg	66 kg
Phase spacing p, mm		400	400	400

*Short-circuit making current I_{ma} restricted to 50 kA.

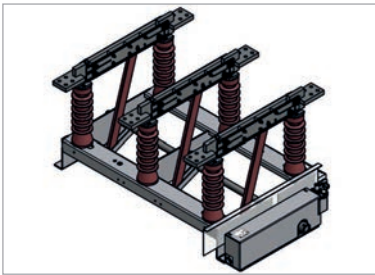
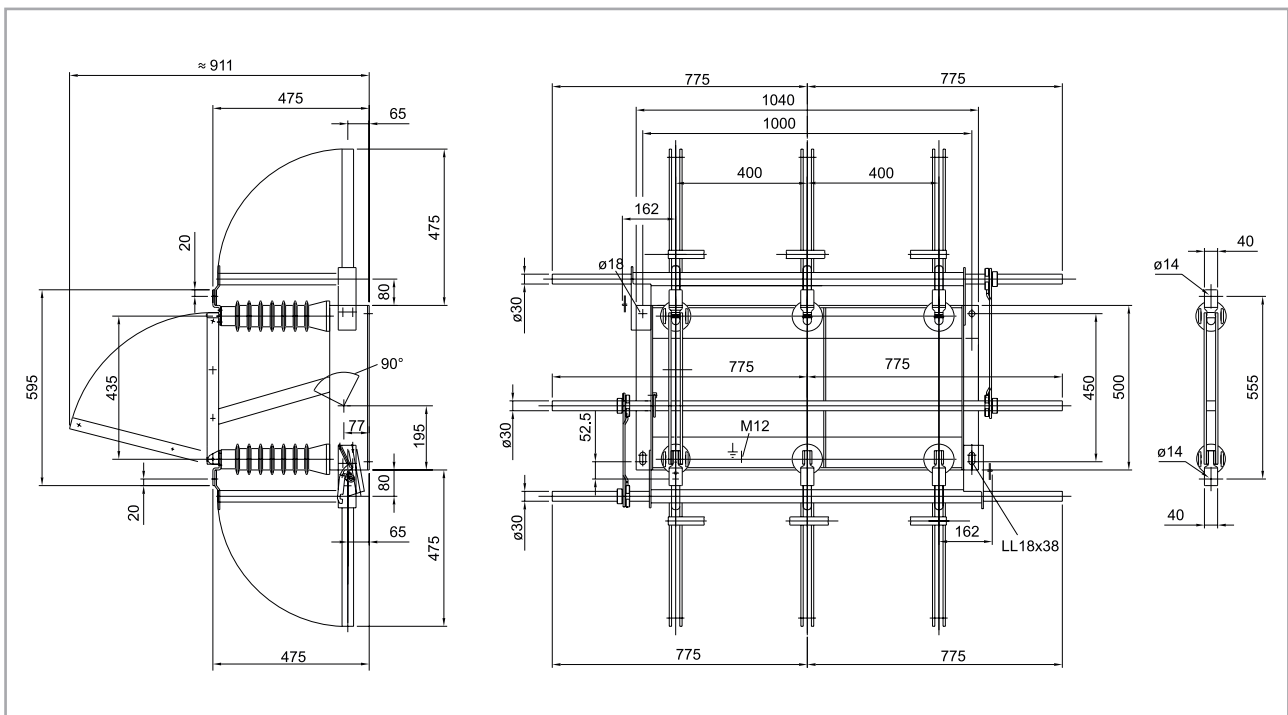

Fig.: ITr 38,5-1600-40

Accessories:

- Earthing switch
- Mechanical interlocking device
- Motor drive (UM 10 and UM 50)
- Auxiliary switch

Diagram for ITr 38,5-630-20 / Diagram number 099827



DRIESCHER – 3-pole indoor disconnecter

ITr 38,5-...-... ; (Ur 38,5 kV)

Diagram for ITr 38,5-1600-40 / Diagram number 104596

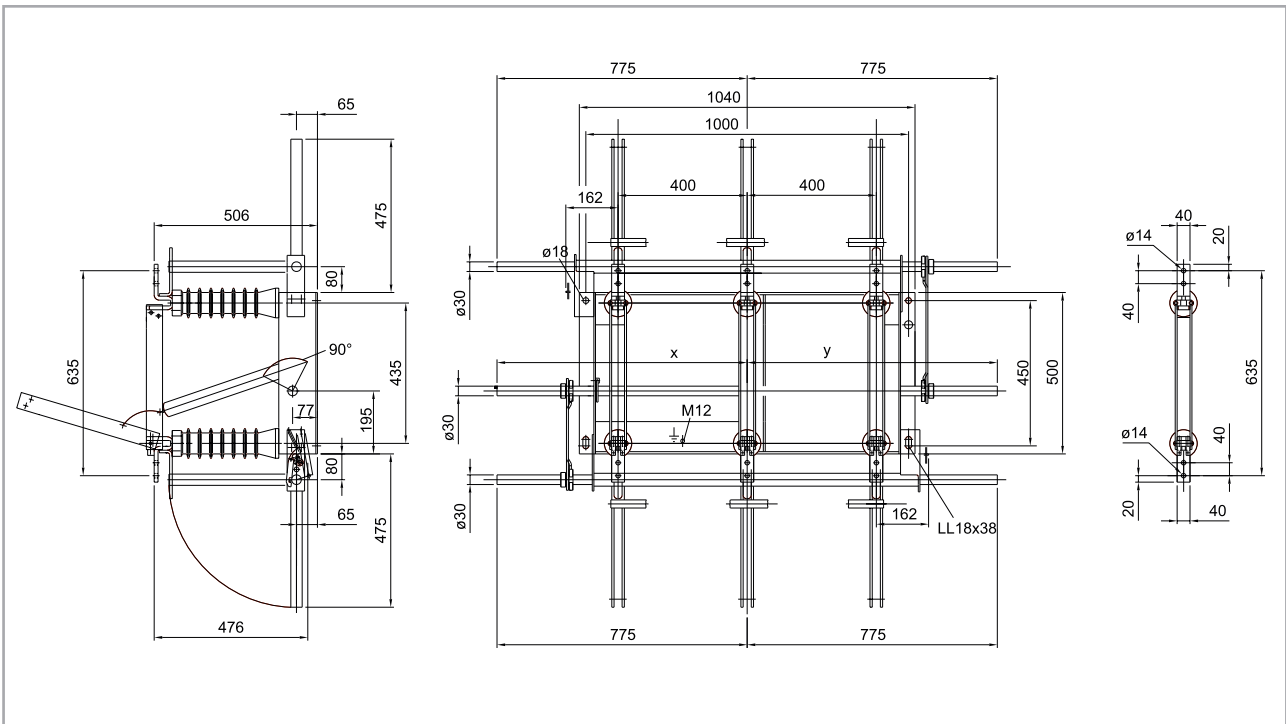
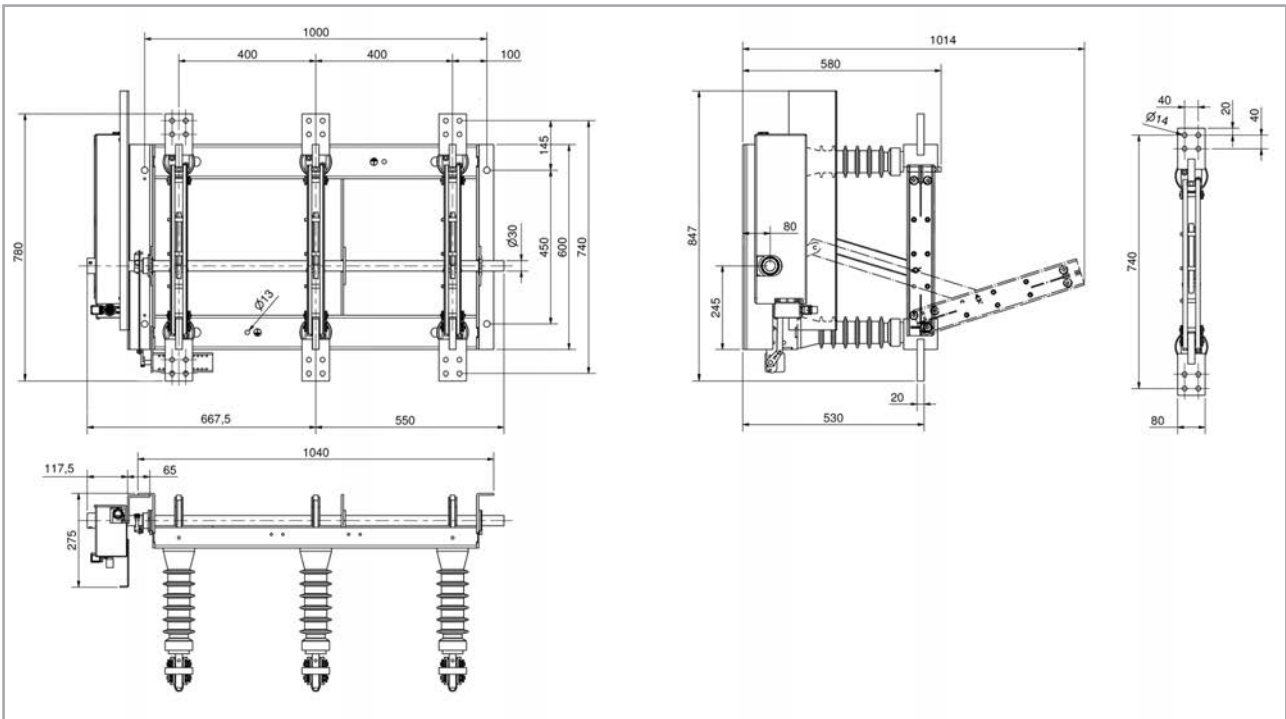

Diagram for ITr 36-2500-50 / Diagram number 110770



DRIESCHER – 3-pole indoor disconnecter

ITr 36/38,5-...-... ; (Ur 40,5 kV)

Switch type		ITr 38,5-1600-40	ITr 38,5-2500-50	ITr 36-4000-50
Rated voltage	U_r	40,5 kV	40,5 kV	40,5 kV
Rated frequency	f_r	50/60 Hz	50/60 Hz	50/60 Hz
Rated current	I_r	1600 A	2500 A	4000 A
Rated short-time withstand current	I_k	40 kA	50 kA	50 kA
Rated short-circuit duration	t_k	3 s	3 s	3 s
Rated peak withstand current	I_p	100 kA	125 kA	125 kA
Rated lightning impulse withstand voltage	U_p			
- phase to earth		180 kV	180 kV	180 kV
- via the isolating distance		210 kV	210 kV	210 kV
Rated power frequency withstand voltage	U_d			
- phase to earth		80 kV	80 kV	80 kV
- via the isolating distance		90 kV	90 kV	90 kV
Diagram number		108705	108367	113928
Mechanical service life		M2	M2	M2
Motor drive		Optional	Optional	standard UM10
Optional Earthing switch		ES 38,5-31,5*	ES 38,5-31,5*	ES 38,5-31,5*
Weight (approx.)		75 kg	115 kg	175 kg
Phase spacing p, mm		400	500	500

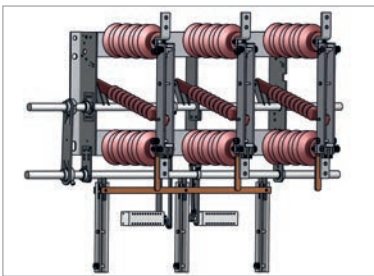
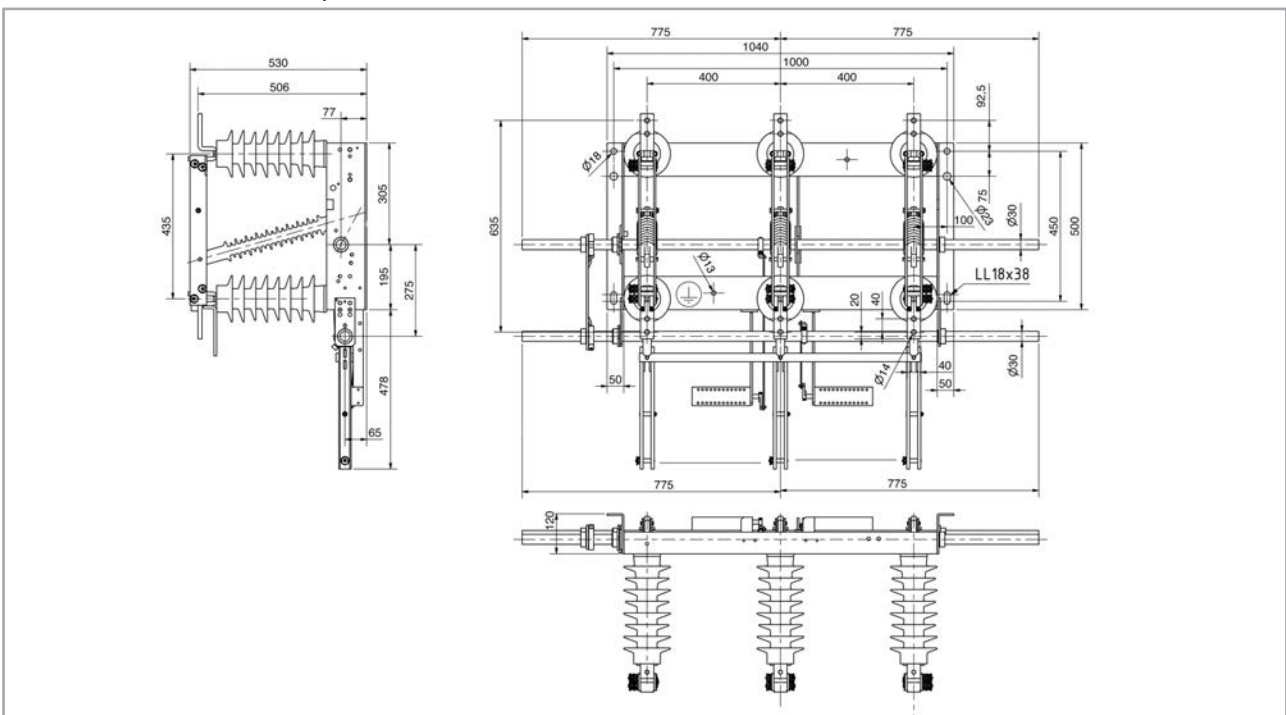

Fig.: ITr 38,5-1600-40

*Short-circuit making current I_{ma} restricted to 50 kA.**Accessories:**

- Earthing switch
- Mechanical interlocking device
- Motor drive (UM 10)
- Auxiliary switch

Diagram for ITr 38,5-1600-40, U_r 40,5 kV / Diagram number 108705

DRIESCHER – 3-pole indoor disconnecter

ITr 36/38,5-...-... ; (Ur 40,5 kV)

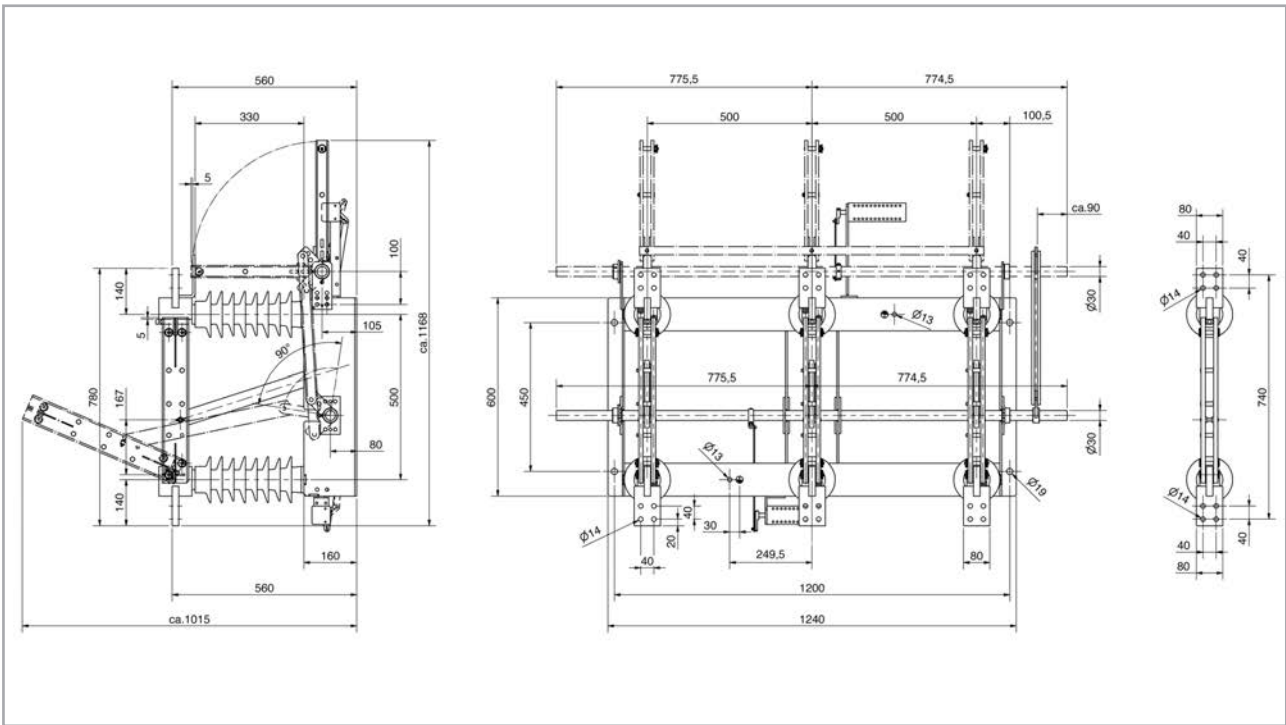
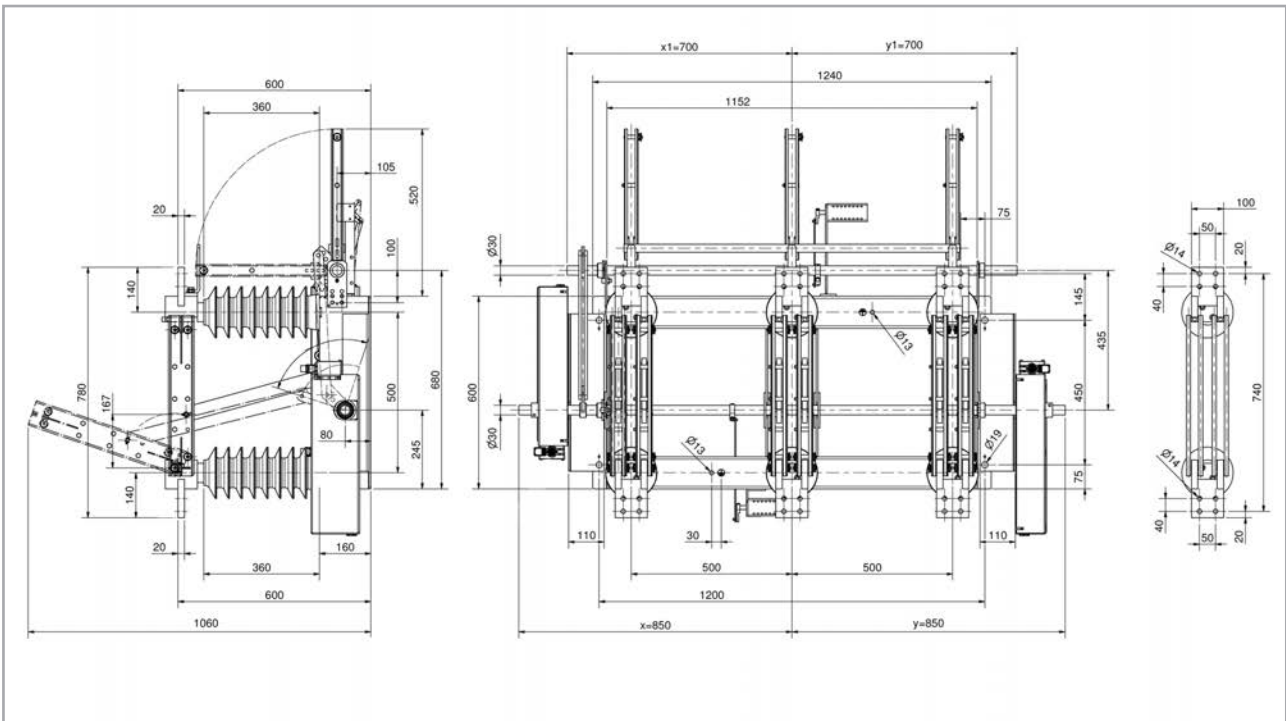
Diagram for ITr 38,5-2500-50, U_r 40,5 kV / Diagram number 108367Diagram for ITr 36-4000-50, U_r 40,5 kV / Diagram number 113928

DRIESCHER – 1-pole indoor disconnecter

ITr ...-630-20-1 (Ur 12 - 36 kV)

Switch type		ITr 12-630-20-1	ITr 24-630-20-1	ITr 36-630-20-1
Rated voltage	U_r	12/ $\sqrt{3}$ kV	24/ $\sqrt{3}$ kV	36/ $\sqrt{3}$ kV
Rated frequency	f_r	50/60 Hz	50/60 Hz	50/60 Hz
Rated current	I_r	630 A	630 A	630 A
Rated short-time withstand current	I_k	20 kA	20 kA	20 kA
Rated short-circuit duration	t_k	3 s	3 s	3 s
Rated peak withstand current	I_p	50 kA	50 kA	50 kA
Rated lightning impulse withstand voltage U_p				
- phase to earth		75 kV	125 kV	170 kV
- via the isolating distance		85 kV	145 kV	195 kV
Rated power frequency withstand voltage U_d				
- phase to earth		28 kV	50 kV	70 kV
- via the isolating distance		32 kV	60 kV	80 kV
Diagram number		028932/1	028932/2	028932/3
Mechanical service life		M2	M2	M2
Motor drive		Optional	Optional	Optional
Weight without motor drive (approx.)		12 kg	16 kg	20 kg

- Accessories:**
- Auxiliary switch
 - Motor drive (UM 10 and UM 50)
 - Earthing switch
 - Mechanical interlocking device

Diagram for ITr 24-630-20-1 / Diagram number 028932

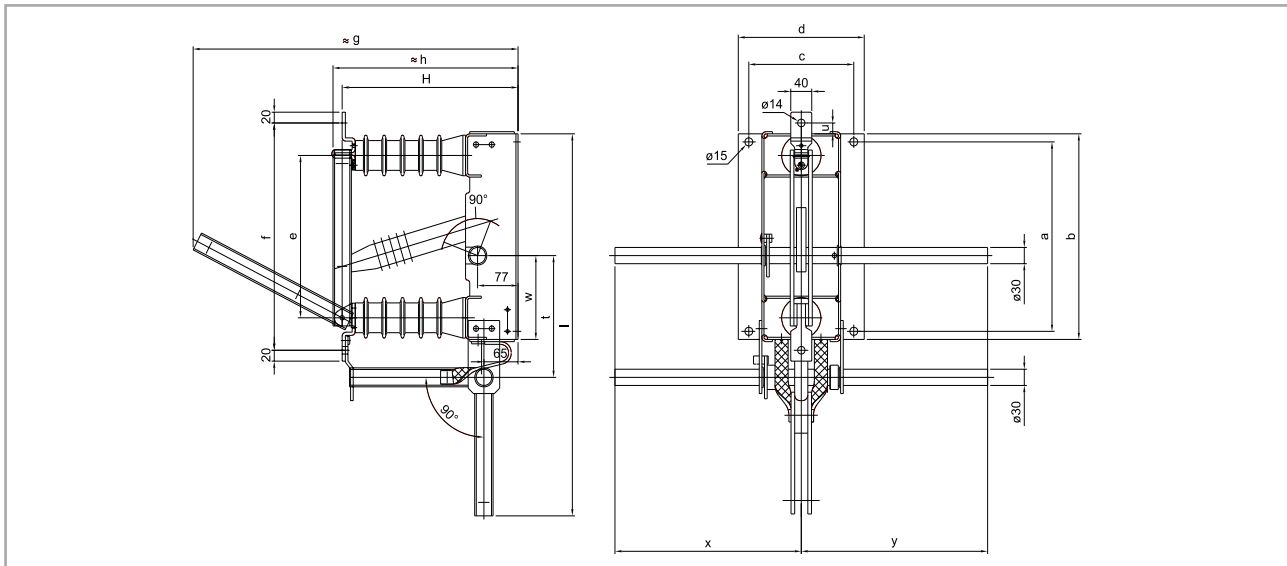

Switch type	Rated voltage kV	a	b	c	d	e	f	≈g	≈h	H	l	t	u	w	x	y
-------------	------------------	---	---	---	---	---	---	----	----	---	---	---	---	---	---	---

ITr 12-630-20-1	12/ $\sqrt{3}$	280	310	180	220	250	370	454	273	255	566	195	30	115	355	355
ITr 24-630-20-1	24/ $\sqrt{3}$	350	380	200	240	300	420	619	353	335	706	225	20	155	355	355
ITr 36-630-20-1	36/ $\sqrt{3}$	450	500	200	240	400	520	833	463	445	926	255	10	195	417.5	417.5

DRIESCHER – 1-pole indoor disconnecter

ITr ...-1600-40-1 (Ur 12 - 36 kV)

Switch type		ITr 12-1600-40-1	ITr 24-1600-40-1	ITr 36-1600-40-1
Rated voltage	U_r	$12/\sqrt{3}$ kV	$24/\sqrt{3}$ kV	$36/\sqrt{3}$ kV
Rated frequency	f_r	50 Hz	50 Hz	50 Hz
Rated current	I_r	1600 A	1600 A	1600 A
Rated short-time withstand current	I_k	40 kA	40 kA	40 kA
Rated short-circuit duration	t_k	3 s	3 s	3 s
Rated peak withstand current	I_p	100 kA	100 kA	100 kA
Rated lightning impulse withstand voltage U_p				
- phase to earth		75 kV	125 kV	170 kV
- via the isolating distance		85 kV	145 kV	195 kV
Rated power frequency withstand voltage U_d				
- phase to earth		28 kV	50 kV	70 kV
- via the isolating distance		32 kV	60 kV	80 kV
Diagram number		IT4-059842	IT4-101566	IT4-095922
Mechanical service life		M2	M2	M2
Motor drive		Optional	Optional	Optional
Weight without motor drive (approx.)		20 kg	25 kg	30 kg

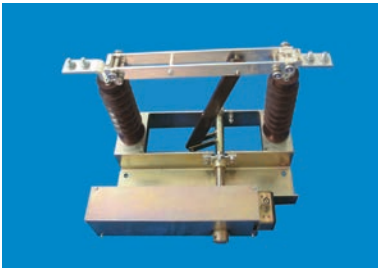

- Accessories:**
- Auxiliary switch
 - Motor drive (UM 10 and UM 50)
 - Earthing switch
 - Mechanical interlocking device

Fig.: ITr 36-1600-40-1

Diagram for ITr ...-1600-40-1

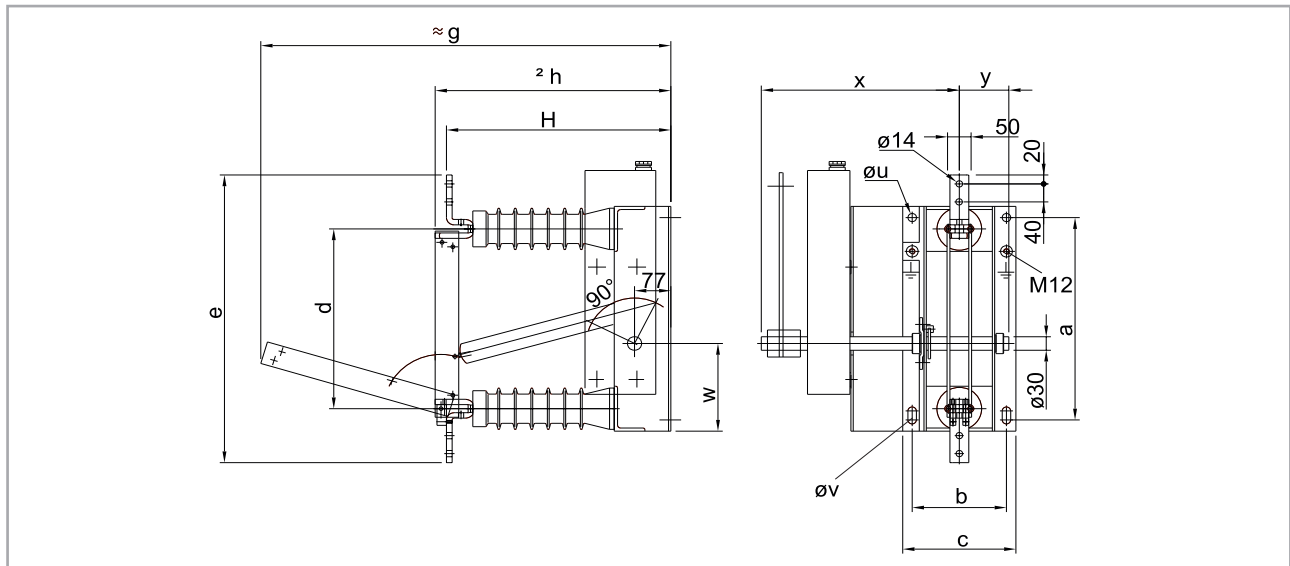

Switch type	Rated voltage kV	a	b	c	d	e	≈g	≈h	H	u	v	w	x
-------------	------------------	---	---	---	---	---	----	----	---	---	---	---	---

ITr 12-1600-40-1	$12/\sqrt{3}$	280	180	220	250	490	525	315	286	15	15	115	311
ITr 24-1600-40-1	$24/\sqrt{3}$	350	200	240	310	550	665	390	366	15	15	155	311
ITr 36-1600-40-1	$36/\sqrt{3}$	450	200	240	400	640	870	500	476	18	LL18x38	195	420

1-pole switching device with higher rated current available on request.

DRIESCHER – 2-pole indoor disconnecter

ITr ...-630-20-2 ; (Ur 12 and 24 kV)

Switch type		ITr 12-630-20-2	ITr 24-630-20-2
Rated voltage	U_r	12 kV	24 kV
Rated frequency	f_r	50/60 Hz	50/60 Hz
Rated current	I_r	630 A	630 A
Rated short-time withstand current	I_k	20 kA	20 kA
Rated short-circuit duration	t_k	3 s	3 s
Rated peak withstand current	I_p	50 kA	50 kA
Rated lightning impulse withstand voltage	U_p		
- phase to earth		75 kV	125 kV
- via the isolating distance		85 kV	145 kV
Rated power frequency withstand voltage	U_d		
- phase to earth		28 kV	50 kV
- via the isolating distance		32 kV	60 kV
Diagram number		100427	108084
Mechanical service life		M2	M2
Motor drive		Optional	Optional
Earthing switch		Optional	Optional
Weight without motor drive (approx.)		30 kg	45 kg
Phase spacing p, mm		210	275

1-pole switching device with higher rated current available on request.

Accessories:

- Auxiliary switch
- Motor drive (UM 10 and UM 50)
- Mechanical interlocking device

Diagram for ITr 12-630-20-2 / Diagram number 100427

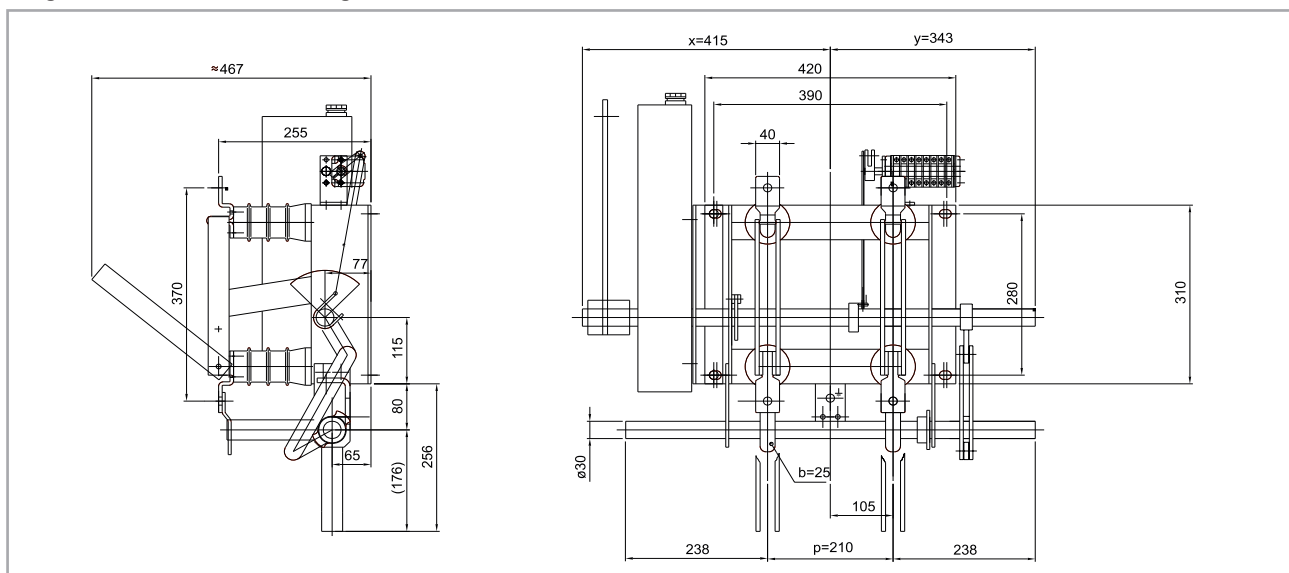

DRIESCHER – 3-pole indoor changeover disconnecter

ITru 12 kV (Ur 12 kV)

Switch type		ITru 12-630-20	ITru 12-1600-40
Rated voltage	U_r	12 kV	12 kV
Rated frequency	f_r	50 Hz	50 Hz
Rated current	I_r	630 A	1600 A
Rated short-time withstand current	I_k	20 kA	40 kA
Rated short-circuit duration	t_k	3 s	3 s
Rated peak withstand current	I_p	50 kA	100 kA
Rated lightning impulse withstand voltage	U_p		
- phase to earth		75 kV	75 kV
- via the isolating distance		85 kV	85 kV
Rated power frequency withstand voltage	U_d		
- phase to earth		28 kV	28 kV
- via the isolating distance		32 kV	32 kV
Diagram number		111949	111853
Mechanical service life		M2	M2
Motor drive		Optional	Optional
Weight (approx.)		50 kg	60 kg

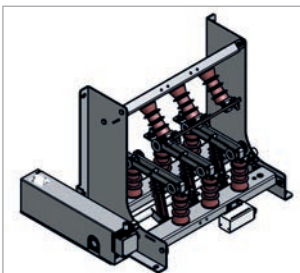
**Accessories:**

- Motor drive (UM 10 and UM 15)
- Auxiliary switch
- Mechanical interlocking device

Fig.: ITru 12-630-20

Diagram for ITru 12-630-20 / Diagram number 111949

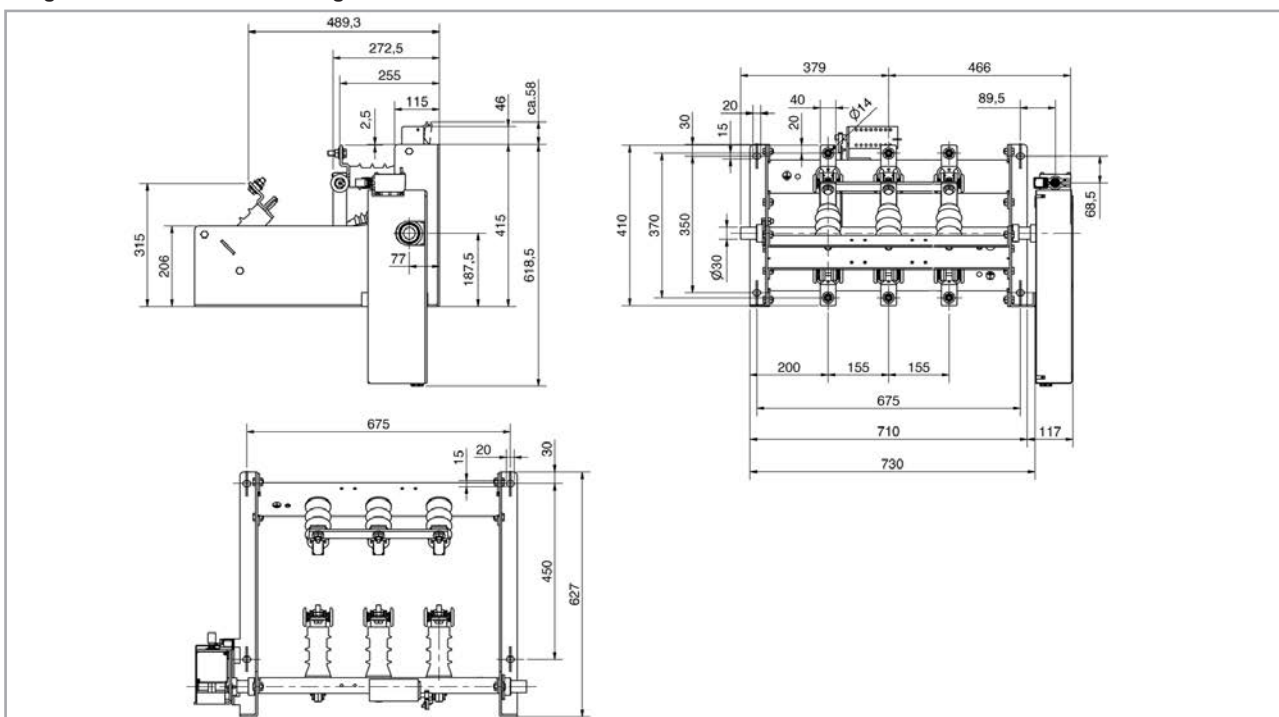

DRIESCHER – 3-pole indoor changeover disconnecter

ITru 12 kV (Ur 12 kV)

Diagram for ITru 12-1600-40 / Diagram number 111853

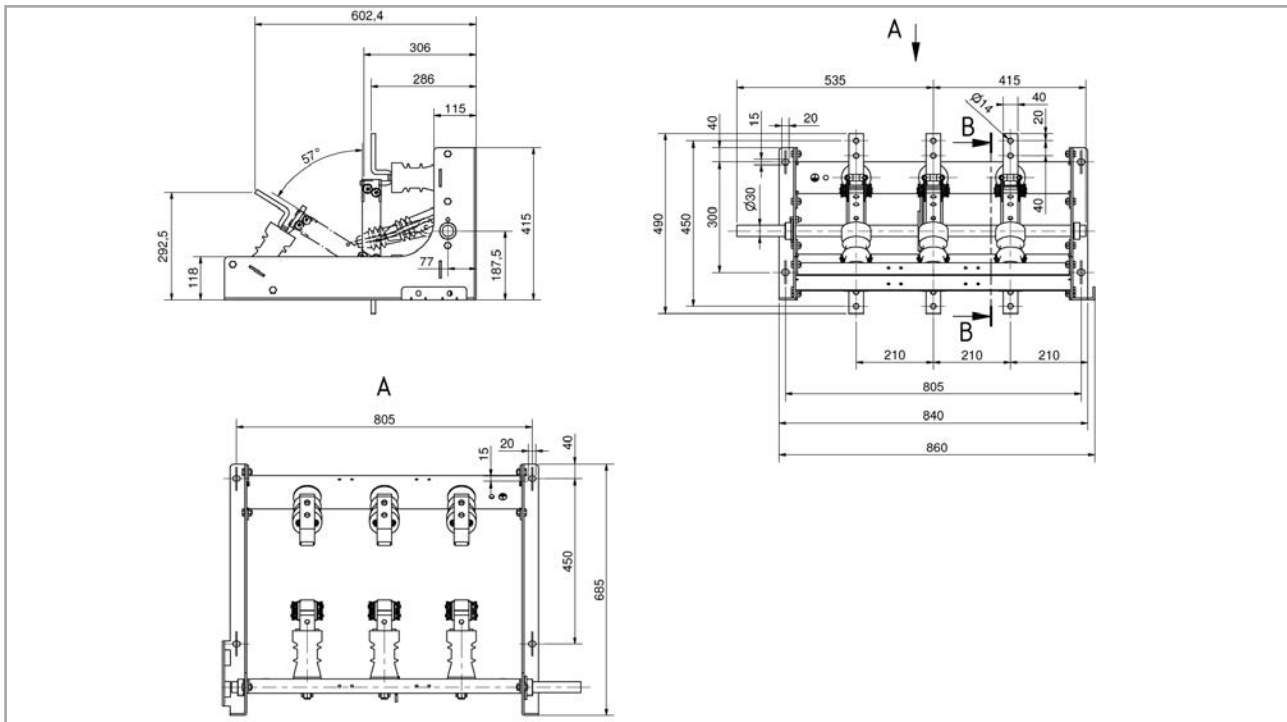

DRIESCHER – 3-pole indoor changeover disconnecter

ITru 24 kV and 36 kV (Ur 24 kV and 36 kV)

Switch type		ITru 24-1600-31,5	ITru 24-2500-50	ITru 36-630-20
Rated voltage	U_r	24 kV	24 kV	36 kV
Rated frequency	f_r	50 Hz	50 Hz	50 Hz
Rated current	I_r	1600 A	2500 A	630 A
Rated short-time withstand current	I_k	31,5 kA	50 kA	20 kA
Rated short-circuit duration	t_k	3 s	3 s	3 s
Rated peak withstand current	I_p	80 kA	125 kA	50 kA
Rated lightning impulse withstand voltage	U_p			
- phase to earth		125 kV	125 kV	170 kV
- via the isolating distance		145 kV	145 kV	195 kV
Rated power frequency withstand voltage	U_d			
- phase to earth		50 kV	50 kV	70 kV
- via the isolating distance		60 kV	60 kV	80 kV
Diagram number		111961	118369	117251
Mechanical service life		M2	M2	M2
Motor drive		Optional	Optional	Optional
Weight (approx.)		70 kg	80 kg	90 kg

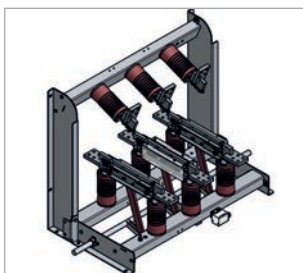

Accessories:

- Motor drive (UM 10 and UM 15)
- Auxiliary switch
- Mechanical interlocking device

Fig.: ITru 24-2500-50

Diagram for ITru 24-1600-31,5 / Diagram number 111961

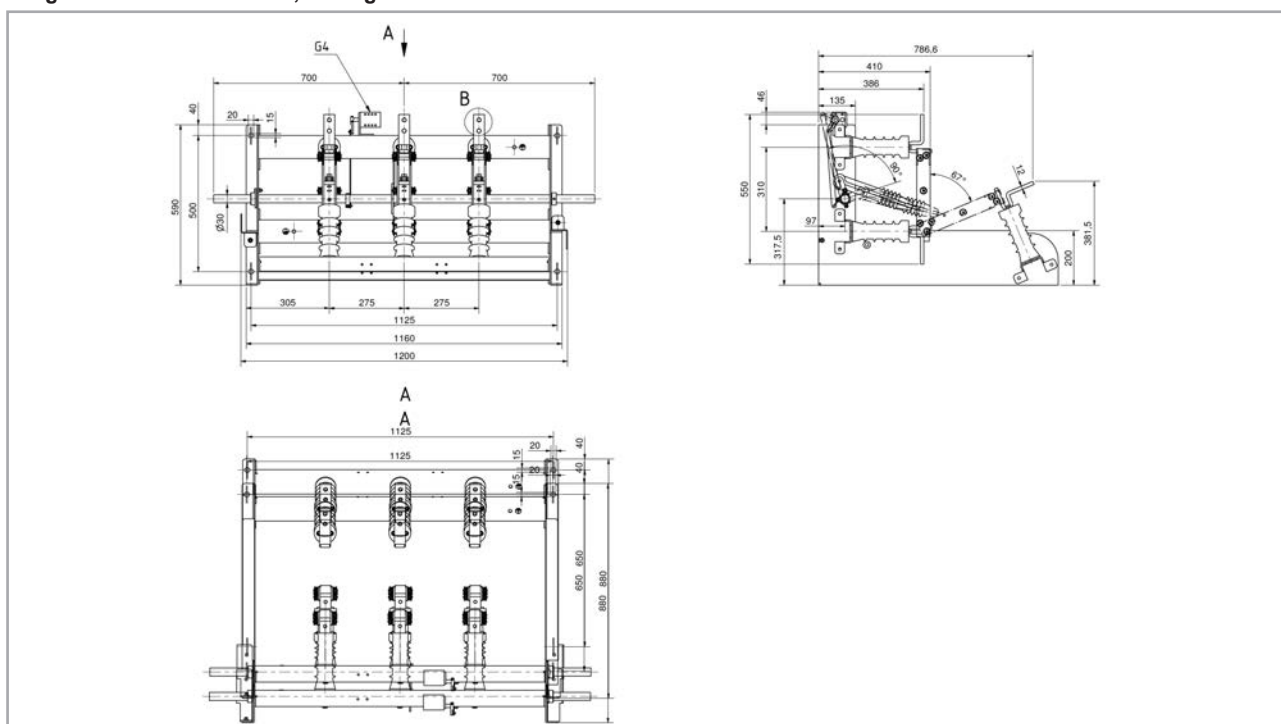

DRIESCHER – 3-pole indoor changeover disconnecter

ITru 24 kV and 36 kV (Ur 24 kV and 36 kV)

Diagram for ITru 24-2500-50 / Diagram number 118369

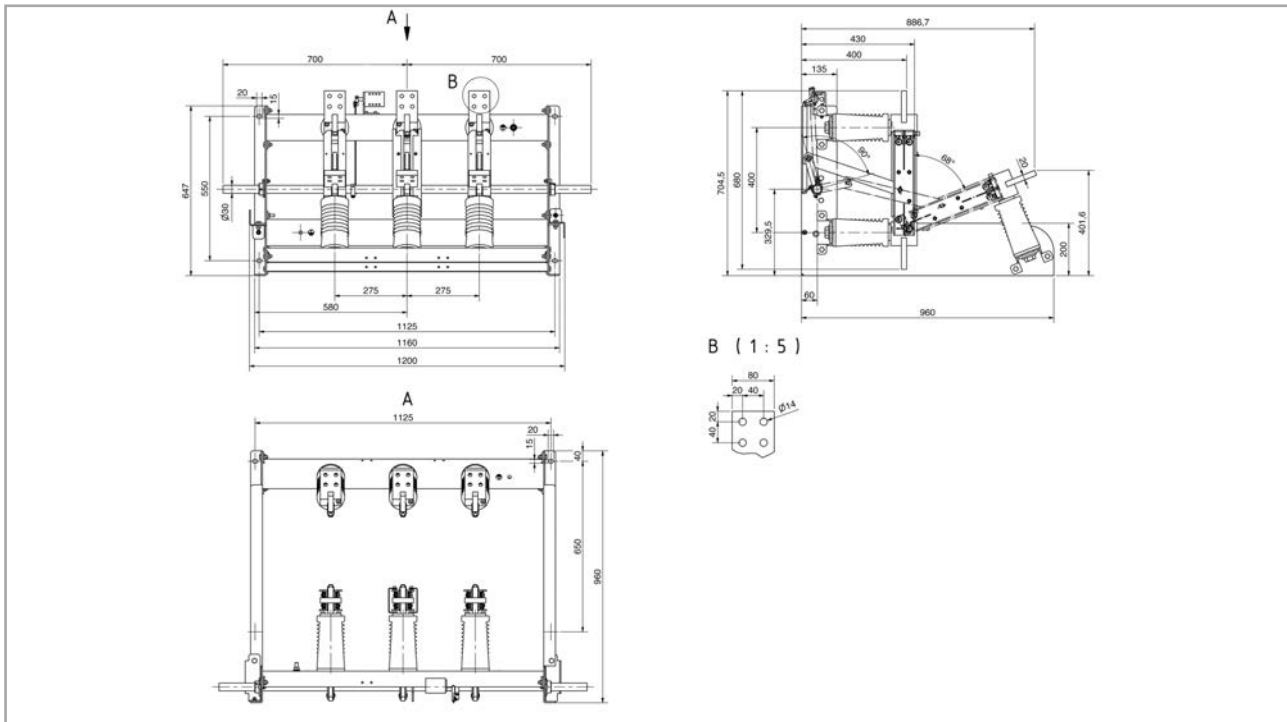
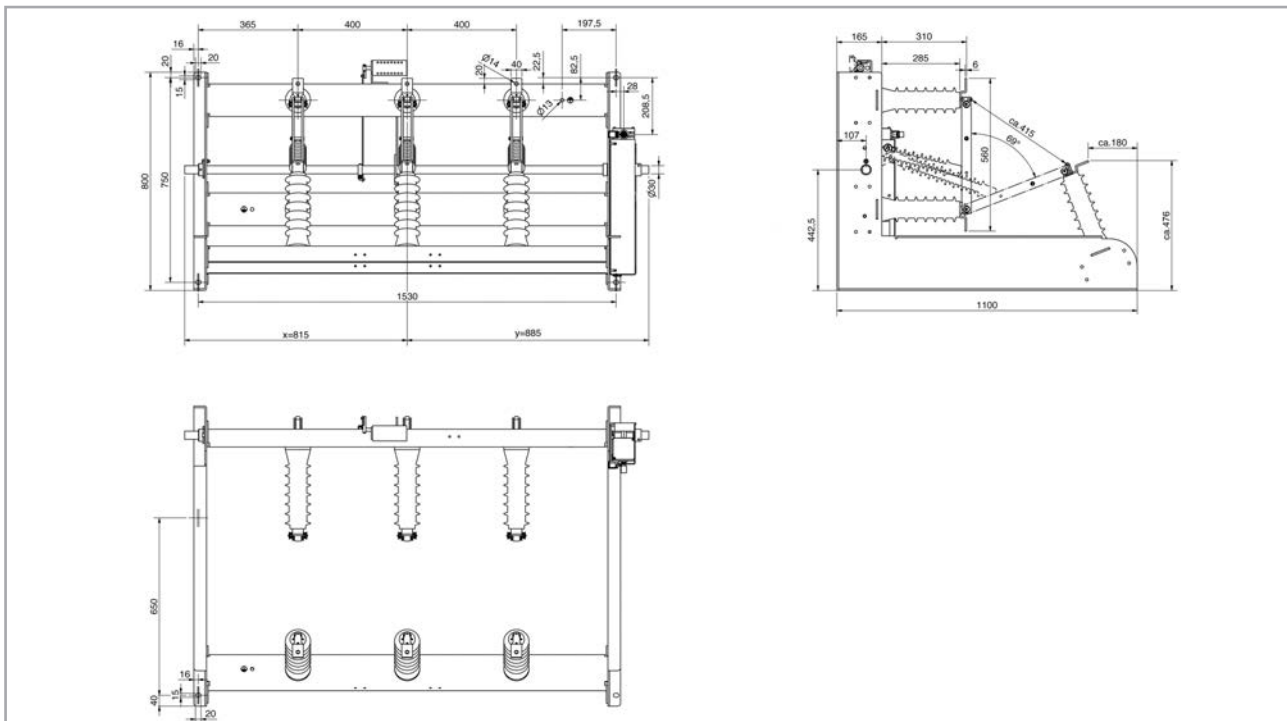

Diagram for ITru 36-630-20 / Diagram number 117251



Please see brochure 774 for information on manual drives and motor drives.

DRIESCHER - 1-pole and 3-pole indoor fuse holders

Ur 12 kV, 24 kV and 36 kV for HV-HBC fuses in accordance with EN 60282-1

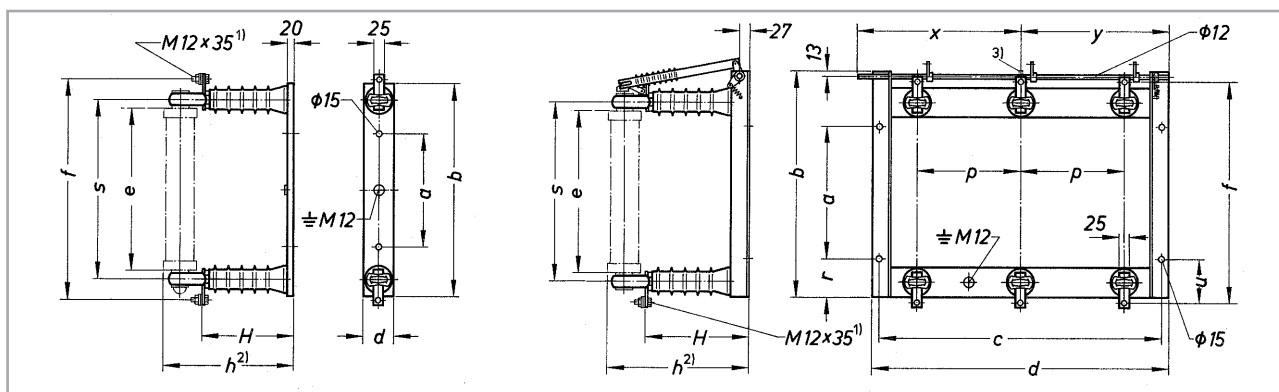

Rated voltage	U_r	12 kV	24 kV	36 kV
Rated frequency	f_r	50/60 Hz	50/60 Hz	50/60 Hz
Rated power frequency withstand voltage	U_d	28 kV	50 kV	70 kV
Rated lightning impulse withstand voltage	U_p	75 kV	125 kV	170 kV
Rated current	I_r	125 A	125 A	125 A
Dimension „e“ from fuse link		292 mm	442 mm	537 mm

• 1-pole fuse holders

Rated voltage kV	Part number	a	b	d	f	h	H	s	Weight kg	Diagram number
12/ $\sqrt{3}$	733 14000	180	405	80	435	267	167	325	3,5	IT 4-002510
24/ $\sqrt{3}$	733 24000	300	565	80	585	347	247	475	5,5	IT 4-002510
36/ $\sqrt{3}$	733 34000	380	670	100	680	437	337	570	11,1	IT 4-002510

• 3-pole fuse holders

Rated voltage kV	Part number without tripping device	Part number with tripping device											Weight kg	Diagram number			
			p	a	b	c	d	f	h	H	r	s			u	x	y
12	733 11000	—	210	280	428	600	640	435	297	197	52,5	325	77,5	—	—	15,5	IT 3-005308
12	—	733 12000	210	280	428	600	640	435	297	197	52,5	325	77,5	360	320	18,0	
24	733 21000	—	275	350	598	750	790	585	377	277	102,5	475	117,5	—	—	26,0	
24	—	733 22000	275	350	598	750	790	585	377	277	102,5	475	117,5	435	395	29,0	
36	733 31000	—	400	450	693	1000	1040	680	467	367	100	570	115	—	—	40,0	
36	—	733 32000	400	450	693	1000	1040	680	467	367	100	570	115	560	520	43,7	

Please see brochure 791 for information on HV-HBC fuses
Please see brochure 773 for information on HV-HBC fuse tongs

Our range of products includes:

Medium-voltage systems

- Single-busbar and duplicate-busbar switchgear
- Fixed mounting, withdrawable design and truck-type units
- Compact switchgear assemblies
- Customer-specific models
- Industrial switchgear
- Power factor correction and filter equipment

Medium-voltage switches

- Indoor load-break switches, disconnectors, and earthing switches (single and triple pole)
- Indoor circuit breakers (low oil content and vacuum)
- Outdoor load-break switches, disconnectors, and earthing switches (single and triple pole)
- Railway switches for power supply and catenary
- High-voltage high-breaking-capacity fuses
- Customer-specific switches

Low-voltage systems

- Open-framework design
- Enclosed switchgear (up to 6.300 A)
- Motor Control Center (MCC)
- Cable and fixed-station distribution cabinets

Low-voltage switches

- Switch disconnectors
- Switching strips and fuse blocks

Compact sub-station

- Concrete construction
- Container construction

Driving gear

- Hand-operated and motor-operated mechanisms for indoor and outdoor application

Accessories

- For medium and low voltage
- For station equipment
- Insulators (0,5 kV - 38,5 kV)
- Plastic and glass fibre-reinforced plastic screening

Service

- Maintenance and Service of all switches and switchgear
- Training courses and seminars
- Thermography; Live-line working

Dimensions, weights, diagrams and descriptions in this brochure are non-binding. Subject to change without notice.

STROM • SICHER • SCHALTEN

Printed on chlorine free bleached paper. For nature's sake.

**ELEKTROTECHNISCHE WERKE
FRITZ DRIESCHER & SÖHNE GMBH**

D-85366 Moosburg • Phone: +49 8761 681-0 • Fax: +49 8761 681-137
www.driescher.com info@service@driescher.de

