

Operating Instruction for

DRIESCHER - Circuit - breaker panels

- for fixed mounting type WL
- withdrawable design type WEL
- withdrawable type in 2- or 3-
compartment design E2K, E3K

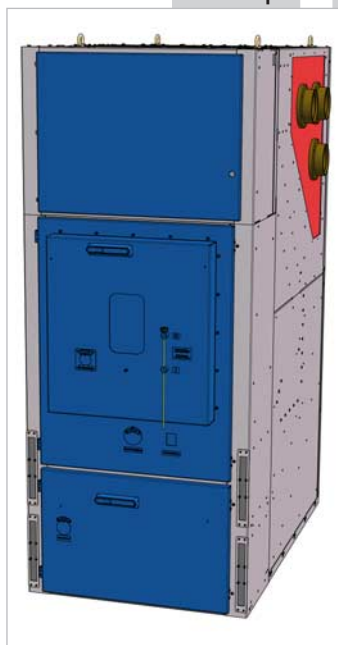

Driescher Moosburg
Strom • Sicher • Schalten
www.driescher.de

24kV

ELEKTROTECHNISCHE WERKE
FRITZ DRIESCHER & SÖHNE GMBH

D-85366 Moosburg • Phone: +49 8761 681-0 • Fax: +49 8761 681-137
www.driescher.com infoservice@driescher.de



- 2 General notes, Operating conditions
- 3 Shipping, Transport, Storage, Installation, Earthing, Cable mounting and Cable connection
- 4 Operation Withdrawable Design Type WEL
- 5 Operating Instruction for Service-Lift Truck
- 6 Operation Fixed mounting Type WL
- 7 Operating Instruction for Service Truck
- 8 Operation 2- or 3-Compartment Design Type E2K or Type E3K
- 10 Operation 3-Compartment Design Type E3K24-101624
- 11 Commissioning, Maintenance, Service



General notes

These operating and maintenance instructions must always be kept at the place of installation and must be available to operating personnel at all times.

The operating and maintenance personnel must have read and understood these instructions prior to the commencement of any work.

Correct transport, storage, installation and assembly, as well as careful operating and commissioning are essential to ensure the satisfactory and safe operation of these switchgears.

Guarantee

Driescher shall not accept any liability for damage which is based on incorrect use, incorrect implementation of work or work carried out by non-trained persons, or third party liability.



Warning

During the operation of these electrical switchgears some parts are inevitably under hazardous voltage and mechanical parts, also those remotely controlled, may move fast.

Non-observance of the warning signs can lead to severe injury or damage to property.

Only appropriately qualified personnel, as specified in the VDE 0105 (trained electricians) are to work on this equipment or in the vicinity thereof.

These persons must have a sound knowledge of all general regulations; VDE/IEC specifications, 5 rules on safety in compliance with VDE, safety regulations, accident prevention regulations as well as all warnings and maintenance measures given in these instructions.

Please take also into consideration the enclosed operating instruction of each switch !

Operating conditions

The switch panels are installed in closed electrical operating areas which are only to be entered by skilled personnel and appropriately instructed persons. The equipment can be used at an altitude of up to 1000 m above sea level. For installations above an altitude of 1000 m the rated insulating level of the switchgear must be corrected accordingly. The switch panels are designed for use under normal

operating conditions in compliance with the standard EN 62271-1.

According to this the following limiting values applies:

Ambient temperature:

Peak value of the ambient temperature +40°C

Average value over 24 hours +35°C

Min. value of the ambient temperature - 5°C

(class "minus 5 Indoor")

Shipping, Transport and Storage

Delivery condition

We deliver individual panels or complete switch gears bolted.

The individual panels or units are usually fully pre-assembled at the manufacturing factory.

Transportation on the site

There are transporting lugs on the top of the switch

panels or units. These must be removed again after installation.

Storage

The switch panels must be appropriately stored in a dry, well-vented area and protected against contamination.

Installation switch panels

Floor properties

A level floor is sufficient.

Compensate any irregularities by metal strips. Make sure to avoid any distortion of the panels and the panel doors!

Floor openings

The openings can also be continuous along the length of the switchgear.

Securing the panels

The switch panels can be bolted directly to the floor of the building or bolted to an iron frame in the floor. The panels can also be installed on an elevated floor.

Earthing, Cable mounting and Cable connection

Connection to the station earth

It is sufficient to connect the station earth once for each switchgear. With switchgear lengths of over 10 m, connect at least twice at places as far away from each other as possible (DIN VDE 0141).

For this purpose there is a panel earthing in each panel, drill $\varnothing 14,5$ mm.

Satisfactory earthing of the entire system is provided by using hot-galvanized sheeting and with the bolting of the individual panels.

The earthing of the switch panel door is about the hinges warranted.

Earthing the cable

Earthing of the cable jacket is carried out at the galvanized cable mounting arms.

Cable fastening and cable connection

The cable and sealing-end fastening as well as the cable connection is to be carried out using the height and width-adjustable galvanized sealing-end mounts.

When connecting the cables always make sure to avoid any tension, thrust or torsion at the connecting contacts.

75 Nm tightening torque.

When connecting the sealing-end fastenings make sure to avoid any torsion at the connecting contacts.

After proper installation and connection of all cable and wires, the switch panel is fully functional. In the product-specific documentation (specification, wiring diagram) you can find all individual functions according to the customer's request.

All switching activities, including the traversing of the circuit breaker into disconnected position, should be carried out with the front door closed so as to ensure maximum operator safety.

It will be possible within a very short period of time to withdraw the circuit breaker for service and maintenance purposes.

For this, either a **service-lift truck** (page 5) or an **auxiliary truck** (page 7). Both are equipped with a docking facility and are hence stable, adjustable for height, and operator-friendly. The service lift-truck also has a hydraulic device to lift and to lower the circuit-breaker.

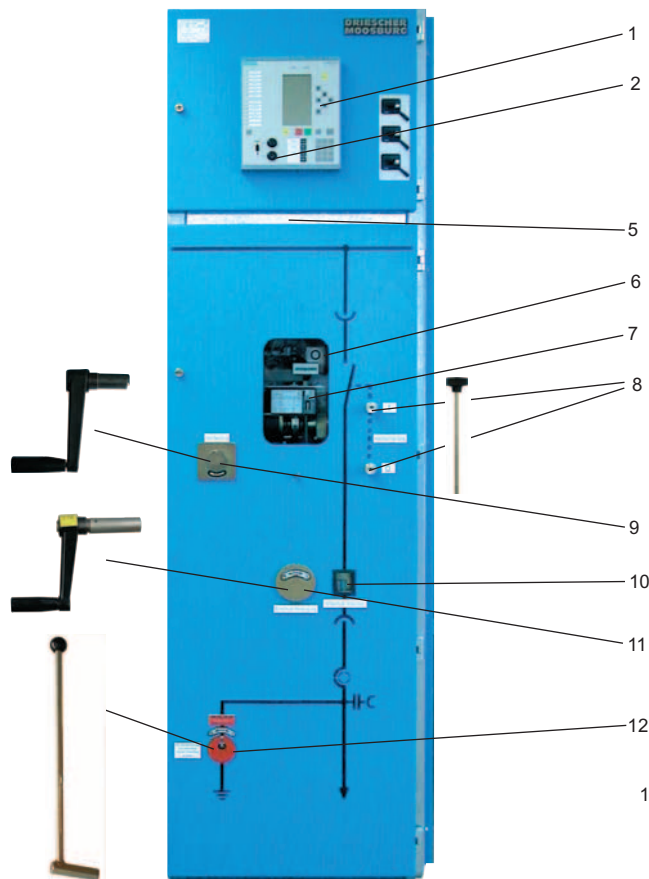

Picture 1:
Withdrawable design circuit-breaker panel

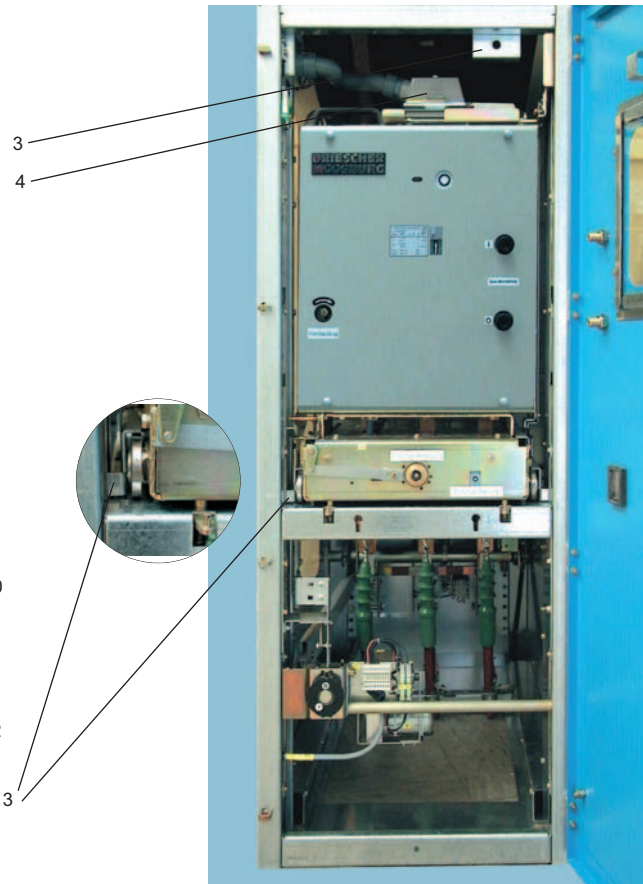

Picture 2: Withdrawable design circuit-breaker panel with open panel door

Operation type WEL

1. The circuit-breaker can be moved into the operating position and into the connecting position either electrically by means of a control unit (1) or manually by means of a hand crank (11).
2. For actuating the circuit-breaker (electrically or manually), the energy-storage mechanism must be charged automatically.

After the connection to the voltage supply through the control line, and after each operation the energy-storage mechanism is charged through the motor drive.

3. Through the inspection window, the condition of the energy-storage mechanism (7) (charged / not charged) and the switching position (6) (1 = closed / 0 = opened) can be seen.
4. All switching operations can be manually actuated, e.g. in case of failure of supply voltage:

It is possible to close and open the circuit-breaker with the mounted auxiliary operating device (8), but the last switching has to be an opening operation. The energy-storage mechanism can be charged by means of a hand crank on the manual winding mechanism (9). The circuit-breaker can be manually removed and inserted by means of the hand crank (11).

The circuit-breaker can only be removed and inserted in the opened condition !

5. The position of the circuit-breaker (inserted = 1 / removed = 0) is shown (10).
6. If desired, the earthing switch (12) can be interlocked with the circuit-breaker and can be operated electrically or manually by means of a rotary handle (12).

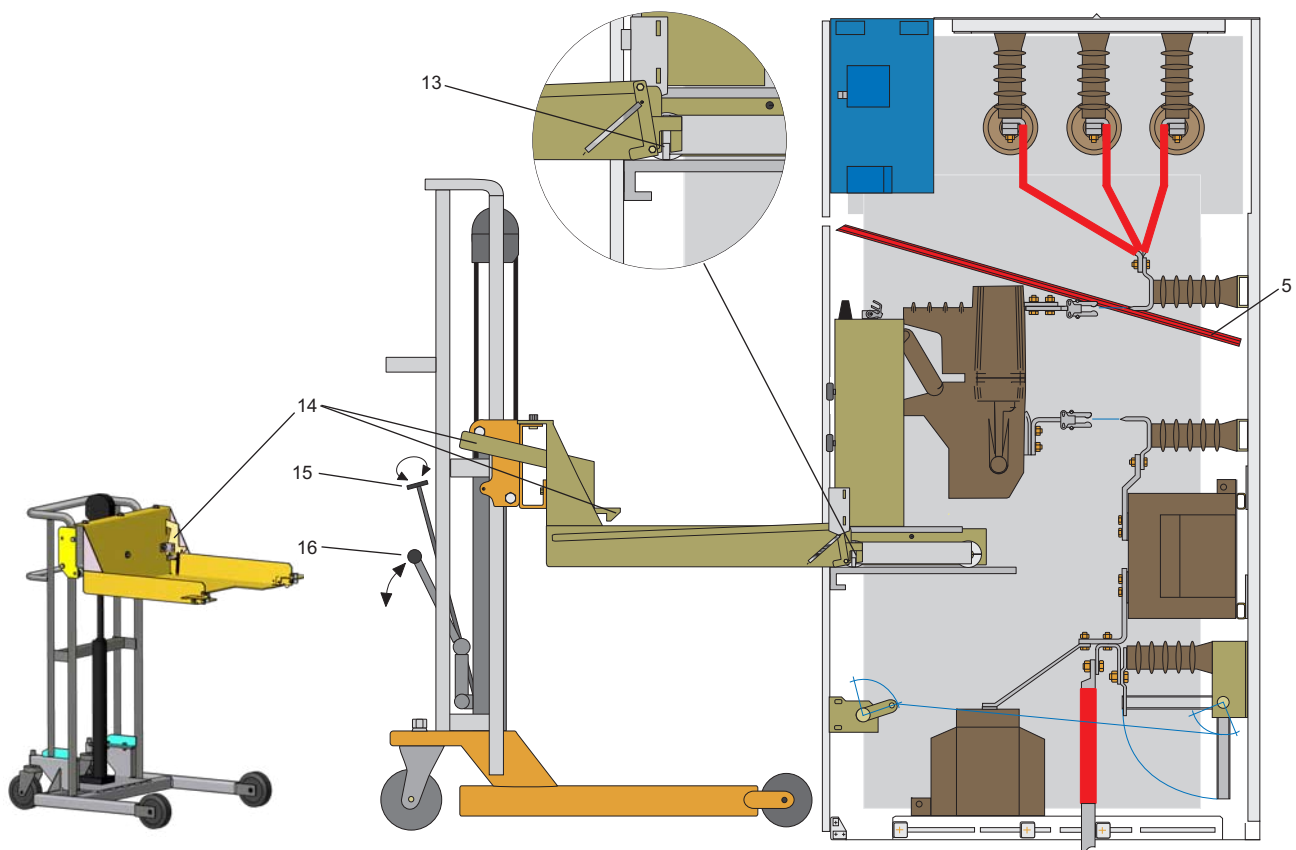

Type WEL:

Circuit-breaker section, in withdrawable-unit design, with a lateral view of the service-lift truck

Withdrawal of the Circuit-Breaker

1. Change-over from remote to local control (2).
2. Open circuit-breaker (1).
3. Withdrawal switchgear truck (1, disconnected position).
4. Close earthing switch (12).
5. Insert insulating plate (5)¹.
6. Open door.
7. Pull plug, (4) and bring into position (3).
8. Bring up service-lift truck (pumping motion, 16), until insertion and docking above the interlocking device (13) is possible.
9. Let service truck, through lowering (rotary lever, 15) latch home into interlocking device (13).
10. Draw out switch until interlocking device on service-lift truck latches home (14).
11. Bring up service-lift truck (pumping motion, 16), and move it away.

Insertion of the Circuit-Breaker

12. On inserting, bring up service-lift truck above interlocking hooks (13), and dock.
13. On lowering the service-lift truck, it should be ensured that the interlocking hooks (13) lock within the section. If docking is carried out properly, it will be possible to insert the circuit-breaker, through releasing the interlocking device (14), as far as it will go into the section.
14. Connect control line (4), and latch.



Immediately after the control line has been placed, the energy-storage mechanism (7) will charged automatically.

15. Close door, remove insulating plate (5)¹, and open earthing switch (12).
16. Now the circuit-breaker may be put back into operation, through local or remote control (2).

¹ not necessary in case of 2- or 3- compartment design- Type E2K, E3K!

All switching activities, including the traversing of the circuit breaker into disconnected position, should be carried out with the front door closed so as to ensure maximum operator safety.

It will be possible within a very short period of time to withdraw the circuit breaker for service and mainten-

ance purposes by means of an **auxiliary truck**.

The service-lift truck (*page 5*) cannot be used for this type WL. The auxiliary truck is equipped with a docking facility and is hence stable, adjustable for height, and operator-friendly.

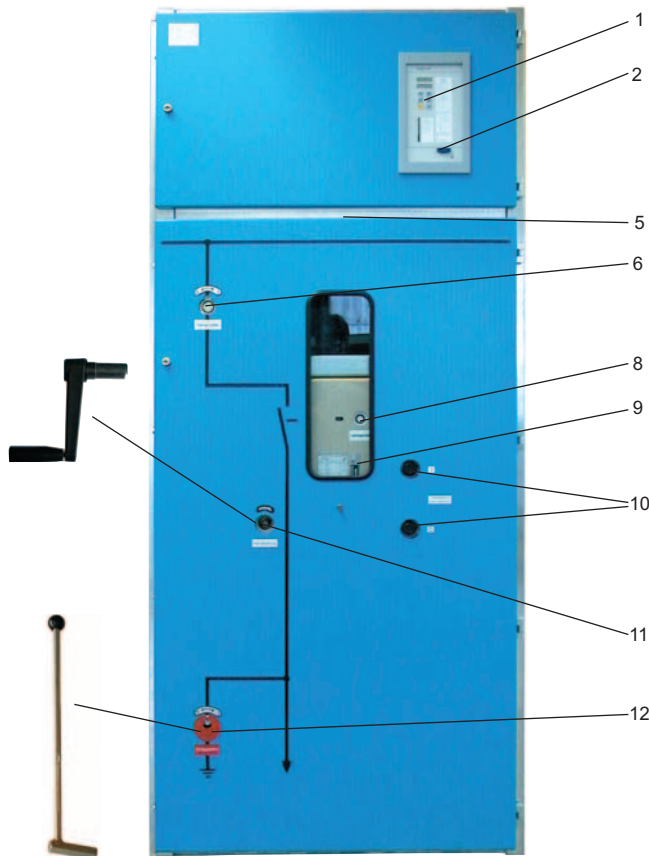

Picture 3: Circuit-breaker panel type WL

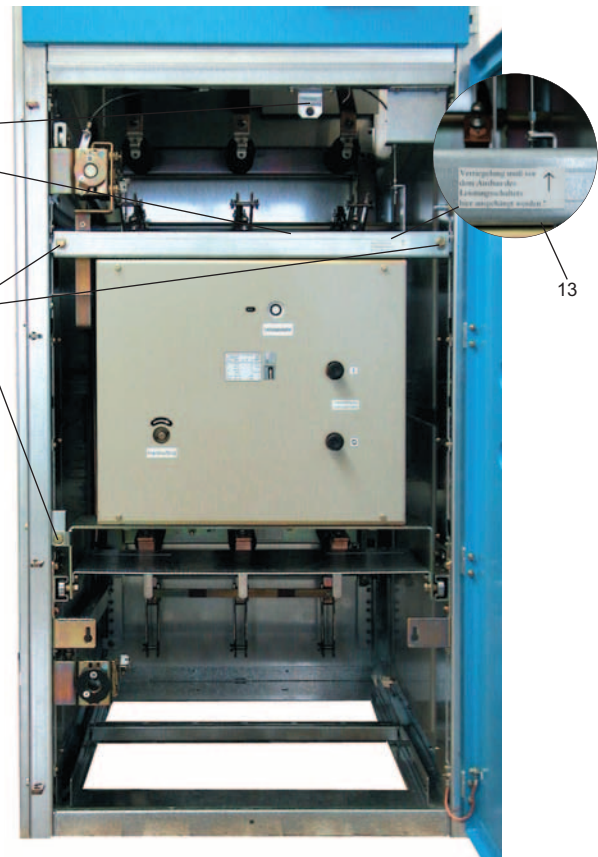

Picture 4: Circuit-breaker panel type WL with open front door

Operation type WL

1. The circuit-breaker can be switched to ON or OFF position (10) locally (manual) or by means of remote control unit (1).

2. For actuating the circuit-breaker the energy-storage mechanism must be charged.

After the connection to the voltage supply through the control line, and after each operation the energy-storage mechanism is charged through the motor drive.

3. Through the inspection window, the condition of the energy-storage mechanism (9) (charged / not charged) and the switching position (8) (1 = closed / 0 = open) can be seen.

4. The energy-storage mechanism can be charged manually by means of a hand crank (11) on the manual winding mechanism in case of failure of supply voltage.

5. Disconnecter (6) and earthing switch (12) can also be operated electrically or manually by means of an actuating crank (12).

Attention! Disconnecter, earthing switch and circuit-breaker can be interlocked all together on desire. Therefore, a faulty operation is practically impossible.

Operating Instruction for auxiliary truck

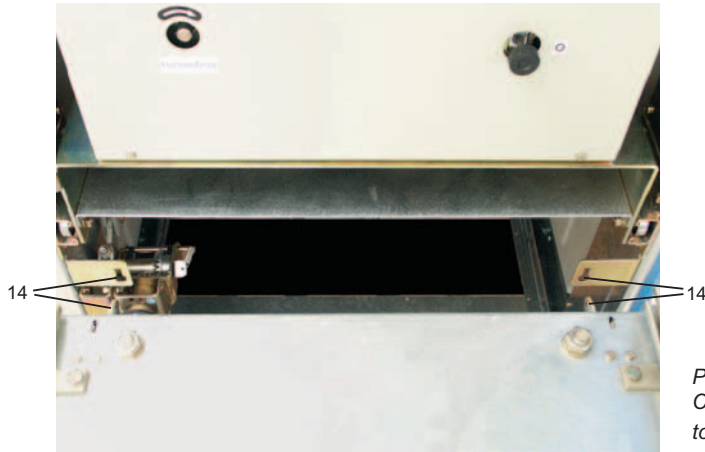

Picture 5:
Connection of the auxiliary truck
to the interlocking



Picture 6:
Interlocking of the auxiliary truck
to the circuit-breaker panel type WL

Withdrawal of the Circuit-Breaker

1. Change-over from remote to local control (2).
2. Open circuit-breaker (10).
3. Open disconnecter (6)¹.
4. Close earthing switch (12).
5. Insert insulating plate (5)¹, not necessary in case of 2- or 3- compartment design!).
6. Open door.
7. Pull plug, (4) and bring into position (3).
8. Remove interlocking rope of the disconnecter at the indicated place (13)¹.
9. Dock the auxiliary truck. Push the interlocking hooks into the openings (14) until an interlocking of the levers (16) is possible through turning about 90° to the inside.
10. After removing the fixing screws (7)¹ draw the circuit-breaker on the auxiliary truck.
11. Interlocking through turning the handles (16) about 90° to the outside, at the same time the circuit-breaker is fixed through the support (15) on the auxiliary truck.
12. Drive away auxiliary truck.

Insertion of the Circuit-Breaker

13. When inserting the circuit-breaker dock the auxiliary truck and push the interlocking hooks into the openings (14) until an interlocking through turning of the handles (15) about 90° to the inside is possible.
14. Push circuit-breaker from the auxiliary truck into the panel and secure with fixing screws (7)¹.
15. Connect control line (4), and latch.



Immediately after the control line has been placed, the energy-storage mechanism (11)¹ will charged automatically.

16. Fix interlocking rope at the indicated place (13)¹.
17. Close door, remove insulating plate (5)¹, open earthing switch (12) and close disconnecter (6)¹.
18. Now the circuit-breaker may be put back into operation, through local or remote control.

¹ not necessary in case of 2- or 3- compartment design- Type E2K, E3K!

All switching operations as well as the moving of the circuit-breaker into the connecting position are done behind the closed front door and are only possible under certain requirements to guarantee the highest possible protection of persons. The circuit-breaker can be removed for service and maintenance purposes in a very short time. For this, either a service-lift truck (page 5) or an auxiliary truck (page 7) can be used.

Both are equipped with a docking facility and are hence stable, adjustable for height, and operator-friendly.

The service-lift truck (page 5) also has a hydraulic device to lift and to lower the circuit-breaker.

The operation for the withdrawable design with 2- or 3-chamber compartment is except point 5 identical to type EL (page 4).

For type E2K and E3K **no insulating plate** is inserted, because the compartment is effected automatically through closing and opening metal shutter ④ in front of the contacts.

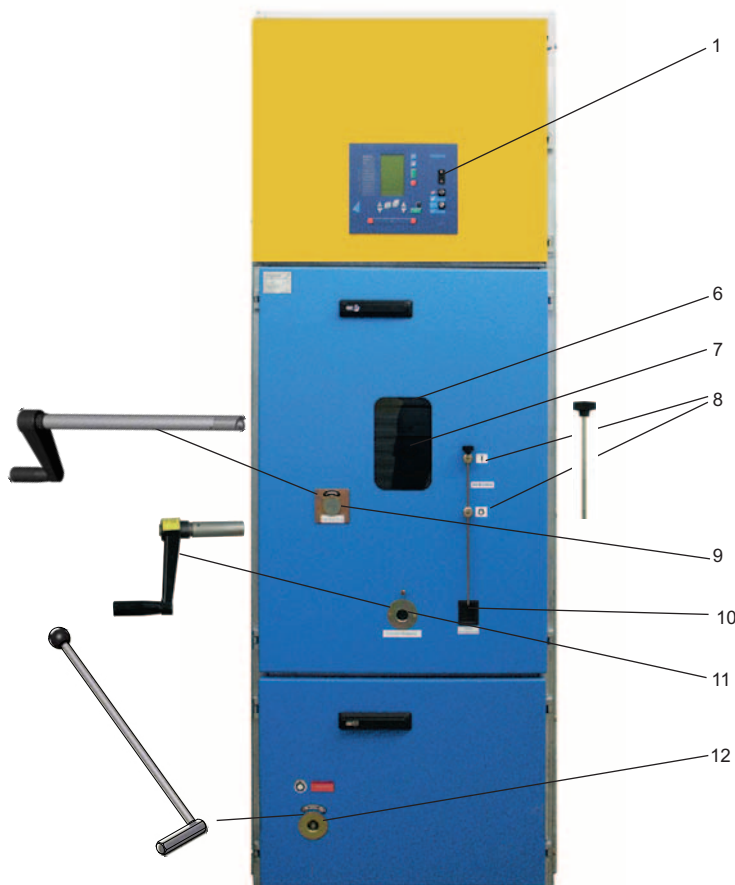

Picture 7: Circuit-breaker panel type E3K with 3 chamber compartment



Picture 8: Open circuit-breaker panel type E3K with 3 chamber compartment without circuit-breaker

- 1 Control device, Operation
- 4 Plug-in
- 6 Position indication Circuit-breaker
- 7 Position indication energy-storage
- 8 Manual operation stick
- 9 Hand-wound mechanism Circuit-breaker
- 10 Position indication withdrawable cassette

- 11 Operation withdrawable cassette
- 12 Operation and position indication earthing switch
- 13/14 Interlocking hooks, Service-Lift Truck
- 15 Rotary lever for lifting down and fixing
- 16 Pumping motion for lifting up

Operating Instruction • 2- or 3-compartment design Type E2K or Type E3K

- ① Busbar chamber
- ② Circuit-breaker chamber
- ③ Partition chamber of cable feeder
- ④ Automatically opening and closing metal shutter

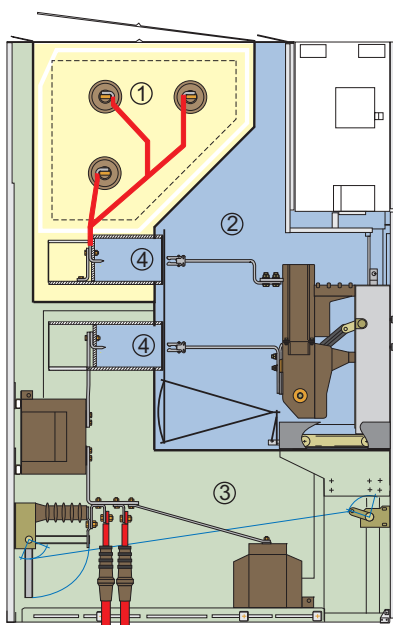

Type E3K: 3-compartment with circuit-breaker in OFF position

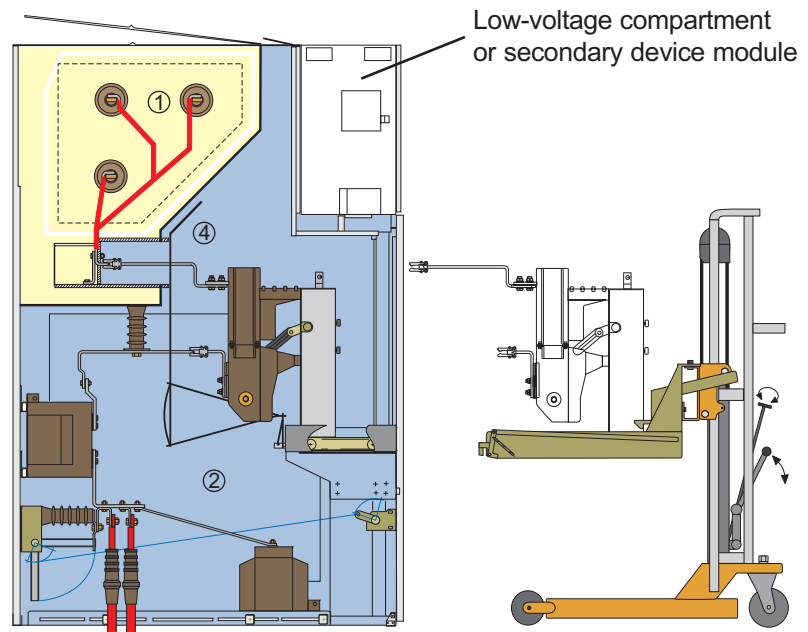

Type E2K: 2-compartment with service truck, circuit-breaker in operating position

Operation Type E2K and E3K

1. The circuit-breaker can be moved into the operating position and into the connecting position either electrically by means of a control unit (1) or manually by means of a hand crank (11).
 2. For actuating the circuit-breaker (electrically or manually), the energy-storage mechanism must be charged.
- After the connection to the voltage supply through the control line, and after each operation the energy-storage mechanism is charged through the motor drive.**
3. Through the inspection window, the condition of the energy-storage mechanism (7) (charged / not charged) and the switching position (6) (1 = closed / 0 = open) can be seen.
 4. All switching operations can be manually actuated, e.g. in case of failure of supply voltage:

It is possible to close and open the circuit-breaker with the mounted auxiliary operating device (8), but the last switching has to be an opening operation. The energy-storage mechanism can be charged by means of a hand crank on the manual winding mechanism (9). The circuit-breaker can be manually removed and inserted by means of the hand crank (11).

The circuit-breaker can only be removed and inserted in the opened condition !

5. The position of the circuit-breaker (inserted = 1 / removed = 0) is shown (10).
6. If desired, the earthing switch (12) can be interlocked with the circuit-breaker and can be operated electrically or manually by means of a rotary handle (12).

When removing the circuit-breaker by means of auxiliary or service-lift truck please pay attention to pages 5 and 7 !

① Busbar chamber

② Circuit-breaker chamber

③ Partition of cable feeder

④ Automatically opening and closing metal shutter

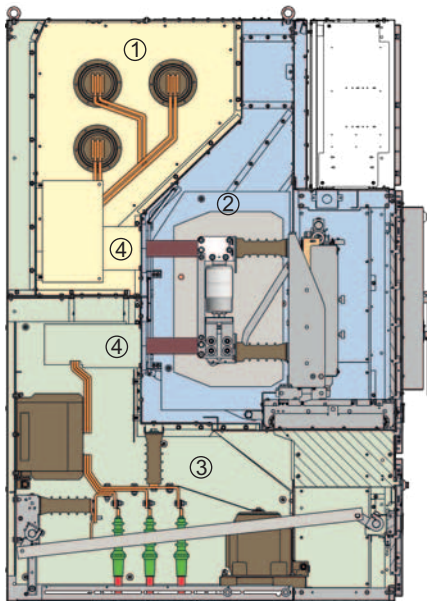

Type E3K 24-101624: Circuit-breaker in OFF-position

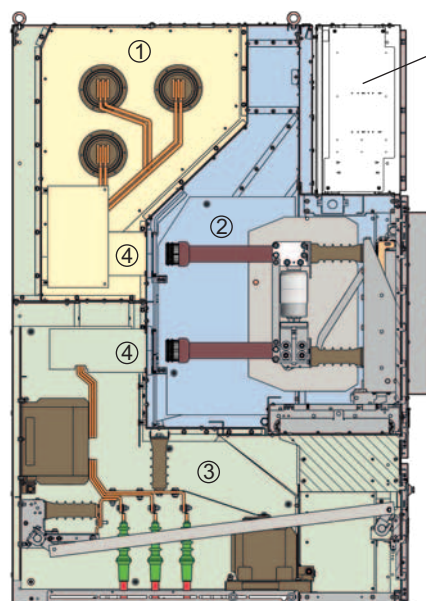

Type E3K 24-101624: with Service-Lift Truck, Circuit-breaker in opening position

Low-voltage compartment or secondary device module

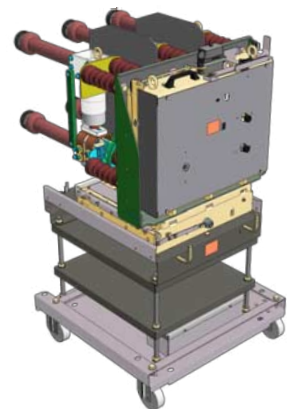

Operation Type E3K24-101624

1. The circuit-breaker can be moved into the operating position and into the connecting position either electrically by means of a control unit (1) or manually by means of a hand crank (11).
 2. For actuating the circuit-breaker (electrically or manually), the energy-storage mechanism must be charged.
- After the connection to the voltage supply through the control line, and after each operation the energy-storage mechanism is charged through the motor drive.**
3. Through the inspection window, the condition of the energy-storage mechanism (7) (charged / not charged) and the switching position (6) (1 = closed / 0 = open) can be seen.
 4. All switching operations can be manually actuated, e.g. in case of failure of supply voltage:

It is possible to close and open the circuit-breaker with the mounted auxiliary operating device (8), but the last switching has to be an opening operation. The energy-storage mechanism can be charged by means of a hand crank on the manual winding mechanism (9). The circuit-breaker can be manually removed and inserted by means of the hand crank (11).

The circuit-breaker can only be removed and inserted in the opened condition !

5. The position of the circuit-breaker (inserted = 1 / removed = 0) is shown(10).
6. If desired, the earthing switch (12) can be interlocked with the circuit-breaker and can be operated electrically or manually by means of an rotary handle (12).

When removing the circuit-breaker by means of auxiliary truck please pay attention to page 7 !

General

Our products have been on the market for many years and thousands of these switchgears are used successfully. We are able to say that the quality of our products is distinguished by a high level of ruggedness and operational safety and reliability. To guarantee that the requirements put to the switchgear are met and to avoid any possible power failures, appropriate maintenance, inspection and possible repair measures are necessary to provide a reliable power supply. The measures employed depend on the age of the switchgear, its operating frequency and the level of the operated currents.

Commissioning

- Before commissioning every kind of installation work as their check must be finished.
- Every switch leaves the manufacturer adjusted and tested. Nevertheless, before commissioning every switch should be tested for proper function by carrying out some switchings in the off-load condition.
- The switchgear should only be commissioned in dry condition. The user has to take care that the substation keeps clean and dry.
- Check of additional equipment
 - e.g. reset short-circuit indicator
- Earthing of cable feeder resp. fuse feeder with free cable connections with belonging earthing switch.
- Switching-on of auxiliary and control voltages.
- All protection measures like short-circuit and earthing connections have to be debiased without endangering of persons.

Inspection and maintenance

In addition to an annual visual inspection, these measures should be carried out after approx. 4 years (DGUV V3), even if the switches are not operated frequently and only under minimal load. Shorter intervals between inspections may be necessary in the event of negative impact from the environment, such as:

- corrosive atmospheres, air with a high dust content, damp plant facilities etc.
- high operating frequency

The switchgear has to be disconnected acc. to the five safety rules.

All insulating parts must be cleaned with a clean, dry cloth (do not use aggressive cleansing agents like solvents).

The contact systems and hinges of the mounted switches have to be cleaned acc. to the applicable manuals.

If damages are discovered, please immediately inform our DRIESCHER-Service staff!

All screwing connections as well as electric contact connections have to be checked and – if necessary – be tightened.

Repair



Disassembly as well as removal and installation of the switch (parts) are only to be carried out by DRIESCHER-Service or appropriately authorized skilled personnel, this being due in particular to the expertise required for the correct adjustment. Only original DRIESCHER parts and accessory or parts cleared from us may be mounted.

Service

Our skilled personnel are always available to assist you in the event of any malfunctions or queries regarding the compatibility, assembly or maintenance - also out of normal office hours. Please always inform us about the data on the type plate.

Phone +49 8761 681-0

Email: service@driescher.de

www.diescher.de

Notes

Dimensions, weights, diagrams and descriptions in this brochure are non-binding. Subject to change without notice.

STROM • SICHER • SCHALTEN

Printed on chlorine free bleached paper. For nature's sake.

**ELEKTROTECHNISCHE WERKE
FRITZ DRIESCHER & SÖHNE GMBH**

D-85366 Moosburg • Phone: +49 8761 681-0 • Fax: +49 8761 681-137
www.driescher.com info@service@driescher.de

