

**DRIESCHER -
Indoor-
Switch-Disconnecter and
switch-fuse combination H29**

- Rated voltage
24 kV and 36 kV
- Rated current 630 A

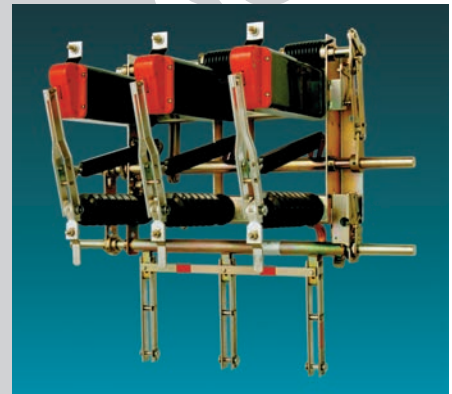

**ELEKTROTECHNISCHE WERKE
FRITZ DRIESCHER & SÖHNE GMBH**

D-85366 Moosburg • Phone: +49 8761 681-0 • Fax: +49 8761 681-137
www.driescher.com info@service@driescher.de



DRIESCHER - Indoor Switch-Disconnecter and switch-fuse combination H 29

acc. to EN 62271-103 and EN 62271-105

- 2 Types of Switch-Disconnectors, Operating conditions
- 3 Main advantages, Energie storage mechanism, Arc extinction
- 4 Additional equipment, Technical data
- 5 Switch-Disconnecter H 29, 630 A, Type EA
- 6 Switch-fuse combination H 29, 630 A, Type SEA
- 7 Switch-Disconnecter H 29, 630 A, Type EA, single-pole
- 8 Range of products includes



Types of Switch-Disconnectors and switch-fuse combinations

For many years DRIESCHER - indoor switch-disconnectors H29 have guaranteed an excellent position in switchgear engineering. These switch-disconnectors master the daily loads exerted under normal switching duty - for interrupting ring feeders, disconnecting network transformers and such - with very high operating frequencies and a minimum amount of maintenance.

These load-break switches are distinguished by simple design, absolute reliability in operation and easy actuation.

* see page 3, *Energie storage mechanism*

- **Type H 29 EA** - with trip-free mechanism*
- **Type H 29 EA, single-pole** - with trip-free mechanism*
- **Type H 29 SEA** - with trip-free mechanism* - as well as with fuse holders mounted below for HV HBC fuses with pin release, for all-pole disconnection of the switch when a fuse operates.

The devices are fitted with an energy storage mechanism for quick-make and quick-break operation.

In switch-fuse combination (Type SEA) only HV HBC fuses with pin release and a tripping impact force of min. 80 N are to be used (DRIESCHER / SIBA; refer also to 791).

Operating conditions

The switches are designed for normal operating conditions according to EN 62271-1 class „Minus 5 Indoor“. The peak value of the ambient temperature is 40° C; the average value over 24 hours is 35° C at best.

The values of the insulating power are related to sea-level. Reduction in insulating capacity at heights up to 1000 m are negligible due to the decreasing insulating capacity of the air. At heights over 1000 m above sea-level the values for rated withstand alternating

voltage and rated impulse withstand voltage must be adjusted (e. g. at a height of 2000 m above sea-level, the insulating power of the air gaps is reduced by a factor of 0.89).

To each switchgear an instruction for transportation, mounting and putting into service is included. This instruction which we certainly would send you in advance, has to be absolutely obeyed.

DRIESCHER - Indoor Switch-Disconnecter H 29

Substantial advantages

- High operating safety
- Isolating distance visible after load disconnection
- High operating frequency with minimum amount of maintenance
- Efficient and reliable arc extinction
- Convenient dimensions
- Easy operation

Energy storage mechanism

One of the robust, low-maintenance energy storage mechanisms of type H 29 EA is mounted on the base frame on which the three switch poles are installed. Hundreds of thousands of these devices have already been used successfully in the Switch-Disconnecter H 22.

The EA energy storage mechanism operates with two torsion springs for quick-make and quick-break operation with trip-free release.

Both torsion springs are tensioned when the switch is closed.

While the ON switch spring relaxes after tensioning and releases the energy for switching ON, the OFF

switch spring remains tensioned and can be released by the tripping device, HV HBC fuse with pin triggering or manually for switching OFF.

With non-manual release the operating shaft remains in ON position and must be moved to the neutral position manually for reclosing.

The actuation for wall-mounting devices can take place via a linkage system operated by a lever or using any of the manual actuators given in or motorized actuator given in brochure 774, according to requirements and situation.

Arc extinction

When closing the switch the switch blade (5) with the arcing tip (6) is withdrawn from the contact jaw (2). The arc which occurs is extinguished in the arcing chamber (4). This chamber is enclosed, has four sections and comprises a pressure and an expansion chamber.

In the pressure chamber two pairs of extinguishing plates (3) are forced into the path of the arc by lateral spring pressure.

At low currents the arc is extinguished by deionising action based on the cooling effect of the walls.

Arc extinction is achieved in the higher current ranges by the arc extinguishing gases produced in the pressure chamber flowing out into the expansion chamber. Based on the rational combination of several arc quenching principles the entire current range of the load-break switch is always effectively covered.

- ① Upper connecting contact
- ⑦ Lower connecting contact

The arcing chambers require no maintenance.

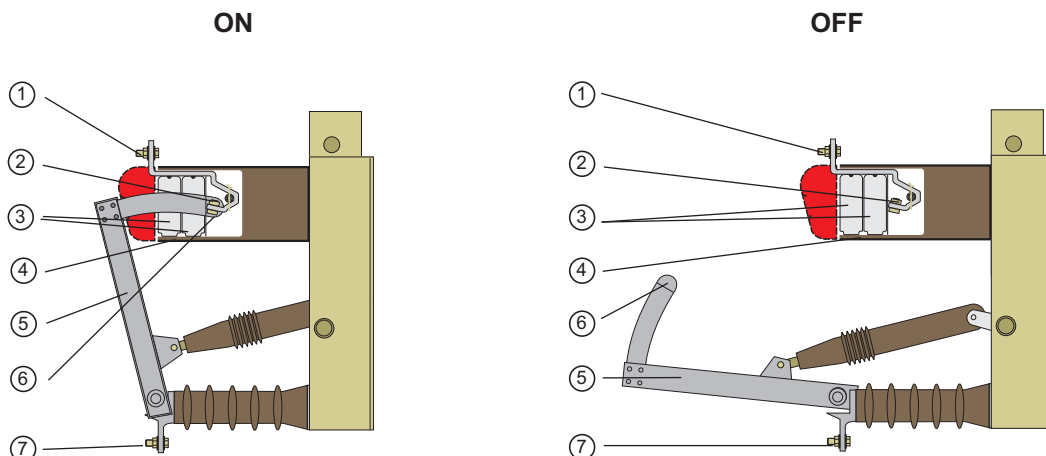

DRIESCHER - Indoor Switch-Disconnecter H 29

Additional equipment

All types are available with earthing switches mounted above and below.

In types H 29 EA the earthing switch is mounted above or below, on the switch frame (retrofitting is possible).

Type H 29 SEA are available with earthing switches integrated in the switch frame.

A **positive mechanical locking** between switch-disconnector and earthing switch is possible.

The earthing switches generally have short-circuit making capacity and are therefore make-proof.

Auxiliary switches, Release coils or shunt releases (110 V, 230 V AC, or 24 V, 60 V, 110 V, 220 V DC) can be mounted on all switches including earthing switches.

All steel parts are galvanised and chromatised.

Design switch-fuse combination

These switch-fuse combination acc. to EN 62271-105 consists of a function unit of switch-disconnector acc. to EN 62271-103 and current-limiting fuses

acc. to EN 60282-1.

The use of the switch-fuse combination is on **transformer protection**, especially for lower and mean power.

The HV HVC fuse in combination with a switch-disconnector provides a simple solution which is very economical to procure and run.

This provides a clear-cut advantage over a circuit breaker with the associated current transformers and over-current time protection.

Besides this, the HV HVC fuse has a current limiting effect when short-circuits occur and reliably interrupts the fault current of the first half cycle.

These properties are advantageous for the dimensional design of the network.

The actuation of the load-break switch H 22 can be carried out with a linkage system operated by a lever or with a motor-operated mechanism. Indoor actuators and accessories see *brochure 774*.

Drive rods and fuse tongs see *brochure 773* (system accessories).

Technical data

acc. to EN 62271-103

Rated voltage	U _r	kV	24	36
Rated frequency	f _r	Hz	50	50
Rated current	I _r	A	630	630
Rated peak withstand current	I _p	kA	50 ¹⁾	50 ¹⁾
Rated short-time current	I _k	kA	20 ¹⁾	20 ¹⁾
Rated short-circuit making current	I _{ma}	kA	36	20
Rated mainly active breaking current	I ₁	A	630	630
Rated closed-loop breaking current	I _{2a}	A	630	630
Rated transformer off-load breaking current	I ₃	A	7	5
Rated cable-charging breaking current	I _{4a}	A	22	24
Rated earth fault breaking current	I _{6a}	A	163	134
Rated cable-charging breaking current under earth fault conditions	I _{6b}	A	35	20
Electrical class			E1	E1
Mechanical class			M1	M1

1) These values also apply to earthing switches or earthing devices

Insulation level acc. to EN 62271-1

Rated voltage	U _r	kV	24	36
Rated lightning impulse withstand voltage 1,2/50 μs	U _w			
Conductor - Earth		kV	125	170
Conductor - Conductor		kV	125	170
Insulating distance		kV	145	195
Rated power frequency withstand voltage	U _d			
Conductor - Earth		kV	50	70
Conductor - Conductor		kV	50	70
Insulating distance		kV	60	80

DRIESCHER - Indoor Switch-Disconnecter H 29

Switch-Disconnecter H 29 EA, 630 A

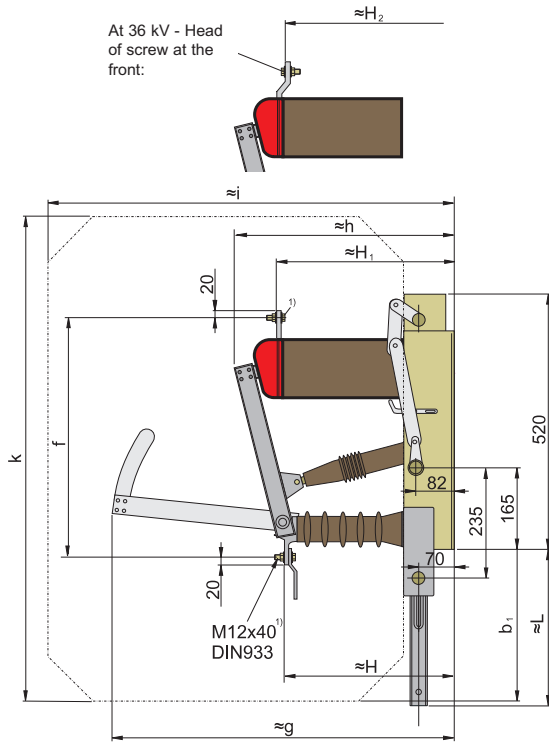

1) Hexagon screw with nut, washer and spring washer

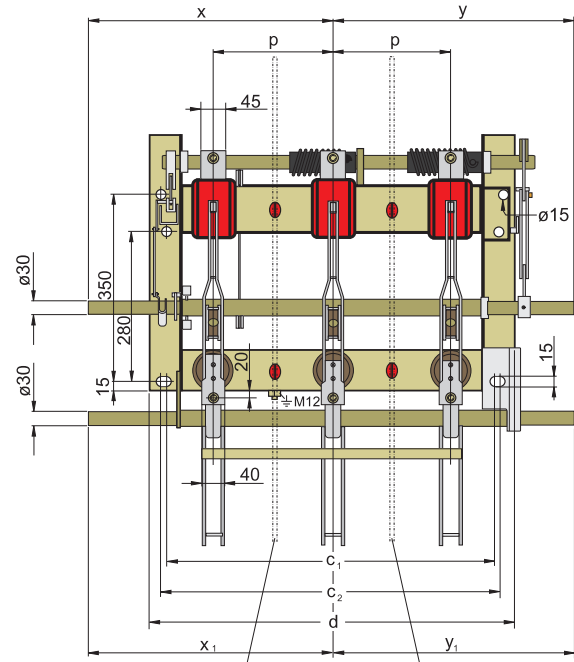

Phase separating plates (5mm thick) only for 36 kV

Type H 29 EA with earthing switch mounted below

Earthing switch with or without mechanical interlocking

• without earthing switch

Rated voltage	Rated current	Part-No.:	p	c ₁	c ₂	d	f	≈ g	≈ h	≈ H	≈ H ₁	≈ H ₂	≈ i	k	x/y	Weight approx. kg	Drawing-No.:
24 kV	630 A	729 52000	275	730	750	790	478	673	445	340	354	439	-	-	565	42,5	LG3-038742
36 kV	630 A	729 62200	275	730	750	790	502	780	550	445	-	-	950	1060	435	74,0	LG3-038742

• earthing switch mounted below

Rated voltage	Rated current	Part-No. with mechanical interlocking	Part-No. without mechanical interlocking	p	b ₁	≈ L	x ₁ /y ₁	Weight approx. kg	Drawing-No.:
24 kV	630 A	729 52014	729 52011	275	-	326	565	55,5	LG3-038742
36 kV	630 A	729 62214	729 62211	275	315	436	435	90,0	LG3-038742

DRIESCHER - Indoor Switch-Disconnecter H 29

Switch-fuse combination H 29 SEA

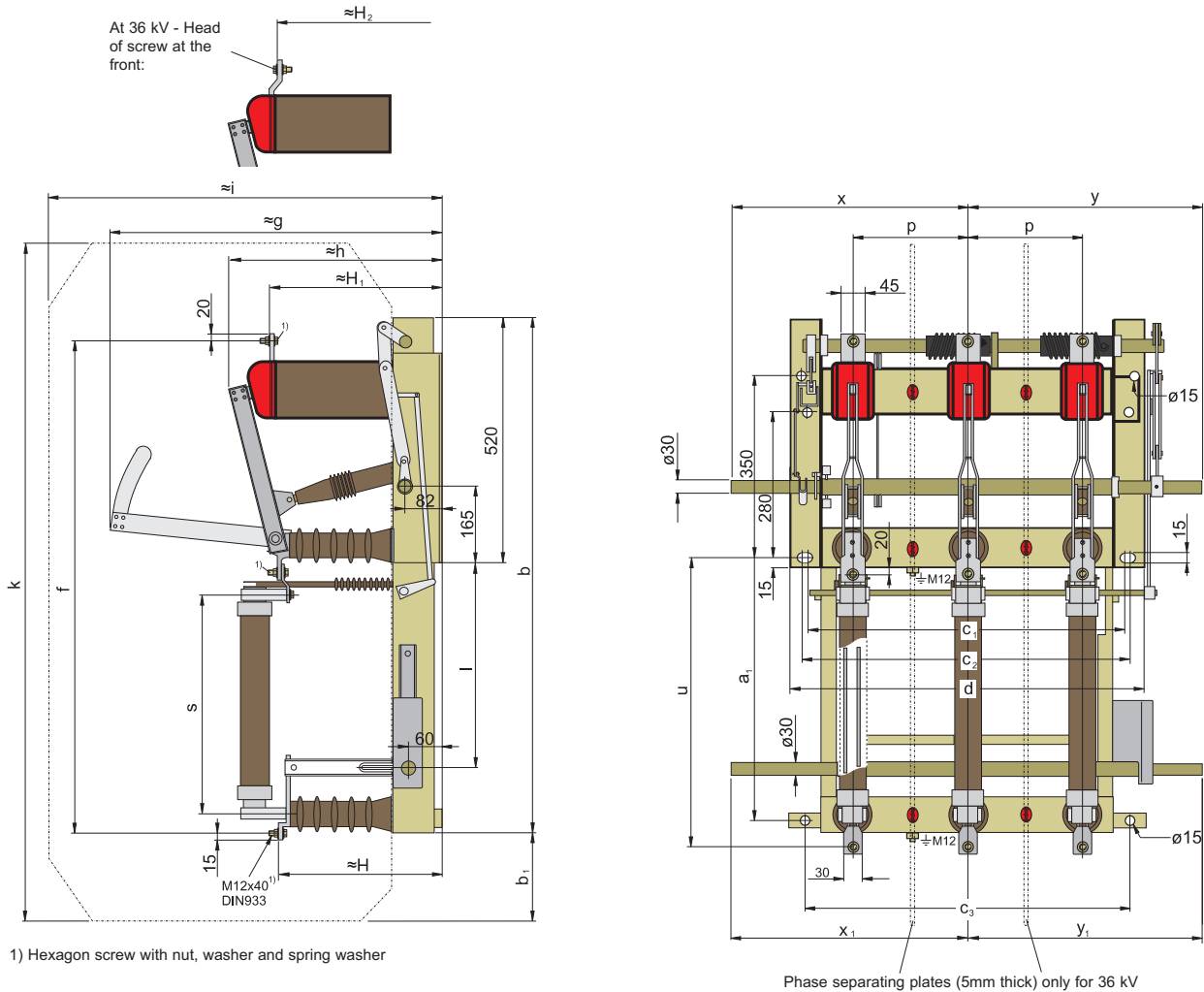

**Type H 29 SEA with earthing switch mounted below
und fuse holders for HV HBC fuses up to 125 A rated current**

• without earthing switch

Rated voltage	Rated current ³⁾	p	a ₁	b	b ₁	c ₁	c ₂	c ₃	d	f	≈ g	≈ h	≈ H ₁	≈ H ₂	i	k
24 kV	630/125 A	275	-	1105	-	730	750	-	790	1058	673	445	335	-	-	-
36 kV	630/125 A	275	655	1200	310	730	750	750	790	1177	780	550	430	439	950	1735

Rated voltage	Rated current ³⁾	p	s	u	x/y	Part-No.:	Weight ²⁾ approx. kg	Drawing-No.:
24 kV	630/125 A	275	475	615	565	729 54000	70,5	LG3-26622
36 kV	630/125 A	275	570	710	435	729 64200	113,5	LG3-26622

• earthing switch mounted below

Rated voltage	Rated current ³⁾	p	l	x ₁ /y ₁	Part-No. with mechanical interlocking	Part-No. without mechanical interlocking	Weight ²⁾ approx. kg	Drawing-No.:
24 kV	630/125 A	275	-	-	729 54014	729 54000	130,5	LG3-26622
36 kV	630/125 A	275	530	650	729 64014	729 64000	132,5	LG3-26622

2) Weights without HV HBC fuses

3) Rated current of the fuse holder 125 A

DRIESCHER - Indoor Switch-Disconnecter H 29

Switch-Disconnecter H 29 EA - single-pole, 630 A

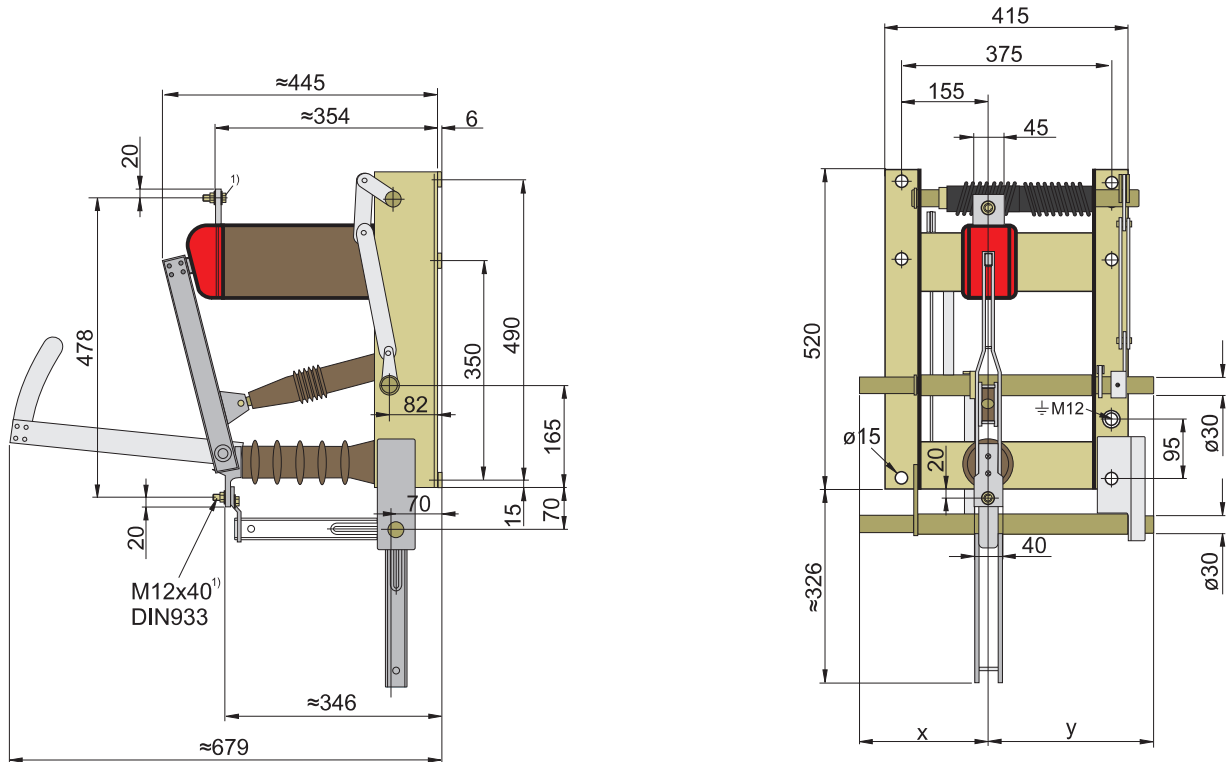

1) Hexagon screw with nut, washer and spring washer

**Type H 29 EA single-pole, with earthing switch mounted below
(Motor drive on the left or right side possible)**

• without earthing switch

Rated voltage	Rated current	Part-No.:	Weight approx. kg	Drawing-No.:
24 kV	630 A	729 52904	29	LG4-49819

• earthing switch mounted below

Rated voltage	Rated current	Part-No. with mechanical interlocking	Weight approx. kg	Drawing-No.:
24 kV	630 A	729 52903	34	LG4-49819

Our range of products includes:

Medium-voltage systems

- Single-busbar and duplicate-busbar switchgear
- Fixed mounting, withdrawable design and truck-type units
- Compact switchgear assemblies
- Customer-specific models
- Industrial switchgear
- Power factor correction and filter equipment

Medium-voltage switches

- Indoor load-break switches, disconnectors, and earthing switches (single and triple pole)
- Indoor circuit breakers (low oil content and vacuum)
- Outdoor load-break switches, disconnectors, and earthing switches (single and triple pole)
- Railway switches for power supply and catenary
- High-voltage high-breaking-capacity fuses
- Customer-specific switches

Low-voltage systems

- Open-framework design
- Enclosed switchgear (up to 6.300 A)
- Motor Control Center (MCC)
- Cable and fixed-station distribution cabinets

Low-voltage switches

- Switch disconnectors
- Switching strips and fuse blocks

Compact sub-station

- Concrete construction
- Container construction

Driving gear

- Hand-operated and motor-operated mechanisms for indoor and outdoor application

Accessories

- For medium and low voltage
- For station equipment
- Insulators (0,5 kV - 38,5 kV)
- Plastic and glass fibre-reinforced plastic screening

Service

- Maintenance and Service of all switches and switchgear
- Training courses and seminars
- Thermography; Live-line working

Dimensions, weights , diagrams and descriptions in the list are non-binding. Subject to change without notice.

STROM • SICHER • SCHALTEN

**ELEKTROTECHNISCHE WERKE
FRITZ DRIESCHER & SÖHNE GMBH**

85366 Moosburg • Tel.: +49 8761 681-0 • Fax: +49 8761 681-137
www.driescher.de info@service@driescher.de

