

DRIESCHER
Indoor -
Switch-Disconnecter and
Switch-fuse combination H 27

- Rated voltage
12 kV and 24 kV
- Rated current
630 A
- 3-pole design

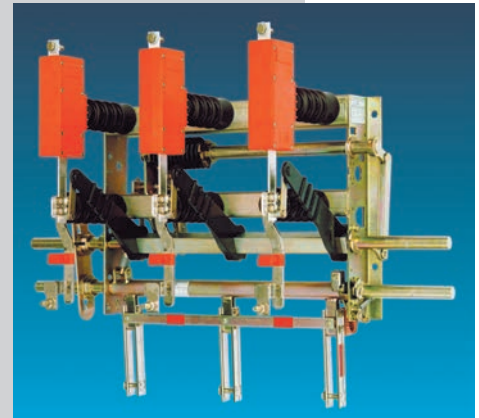

H 27

ELEKTROTECHNISCHE WERKE
FRITZ DRIESCHER & SÖHNE GMBH

D-85366 Moosburg • Phone: +49 8761 681-0 • Fax: +49 8761 681-137
www.driescher.com infoservice@driescher.de



DRIESCHER - Indoor Switch-Disconnecter and Switch-fuse combination H 27

acc. to EN 62271-103 and EN 62271-105



content

- 2 Types of switch-disconnectors, Operating conditions
- 3 Main advantages, Energy storage mechanism, Arc extinction
- 4 Additional possibilities of mounting, Technical data
- 5 Switch-disconnector H 27 for front-panel mounting, Type F-EA and F-EK
- 6 Switch-fuse combination H 27 for front-panel mounting, Type F-SuT
- 7 Switch-disconnector H 27 for wall-mounting, Type EA and EK
- 8 Switch-fuse combination H 27 for wall-mounting, Type SEA
- 9 Switch-disconnector H 27 for lateral mounting, Type EK and EA
- 10 Switch-fuse combination H 27 for lateral mounting, Type SuT
- 11 Switch-fuse combination H 27 for lateral mounting, Type SEA
- 12 Type Switch-fuse combination, Recommended protection

Types of switch-disconnectors and switch-fuse combinations

H 27 F-EK for front-panel mounting
- without trip-free release*

H 27 F-EA for front-panel mounting
- with trip-free release*

H 27 F-SuT for front-panel mounting - with trip-free release*, with two separate cross-rails, respectively with mounted insulators and fuse holders.

H 27 EK for wall mounting and lateral mounting
- without trip-free release*

H 27 EA for wall mounting and lateral mounting
- with trip-free release*

H 27 SEA for wall mounting and lateral mounting
- with trip-free release*, with a cross-rail mounted below with mounted insulators and fuse holders.

H 27 SuT for lateral mounting - with trip-free release*, with a separate cross-rail with mounted insulators and fuse holders.

For switch-fuse combination, HV HBC fuse-links with a pin release force of at least 80 N must be used (DRIESCHER / SIBA; see page 8).

* see page 3, energy storage mechanism

Operating conditions

The use of switchgear under normal operating conditions is specified in the EN 62271-1 as follows:

- The maximum ambient temperature is 40 °C, the average value over a period of 24 h is max. 35 °C. The minimum ambient temperature is -5 °C. For our indoor switches the class "Minus 5 indoors" is specified.
- Solar radiation has no significant impact.
- The altitude at the place of installation is max. 1000 m above sea level.
- The ambient air is to have no significant contamination through dust, smoke, corrosive and/or flammable gasses, fumes or salts.
- The following conditions apply with regard to humidity:
 - average value of relative air moisture measured over 24 h is max. 95 %,
 - average value of water vapour pressure over 24 h is max. 2.2 kPa;
 - average value of the relative air moisture over a period of one month is max. 90%
 - average value of the water vapour pressure over one month is max. 1.8 kPa;

To each switch an instruction for transportation, mounting and putting into service is included. This instruction which we certainly would send you in advance, has to be absolutely obeyed.

DRIESCHER-Indoor Switch-Disconnecter and Switch-fuse combination H 27

Main advantages

- Compact construction
- High switching capacity
- Visible isolating distance after switching OFF
- Perfect functioning
- Simple operation
- High switching rate with a minimum maintenance

Energy storage mechanism

One of the robust, low-maintenance energy storage mechanisms of type EK or EA is mounted on the base frame, on which the three switch poles are installed. Many hundred thousands of these devices have already been used successfully.

The EK energy storage mechanism operates with only a single torsion spring for quick-make and quick-break operation without trip-free release. The torsion spring is tensioned for switching ON or OFF. After tensioning, the spring energy is released for the particular switching operation (ON or OFF).

The EA energy storage mechanism operates with two torsion springs for trip-free quick-make and quick-break operation. Both torsion springs are tensioned when the switch is closed.

The ON switch spring is tripped after tensioning and releases its energy for switching ON, while the OFF switch spring remains tensioned until it is released by the

tripping device, HV HBC (high-voltage, high-breaking capacity) fuse links with striker pin, or manually for switching OFF (trip-free release).

With non-manual release the operating shaft (13) remains in the ON position and must be moved to the neutral position "OFF" manually for reclosing.

Wall-mounting devices can be actuated via a linkage system operated by a detachable lever or by any of the actuators in brochure 774 (*Indoor actuators*).

Lateral mounted switches can be operated directly by fixing a sleeve for D-drives with internal twelve-sided polygon 24 on the operating shaft and using the detachable lever with hexagonal attachment (see brochure 773).

Front-panel mounted devices can be operated by means of a detachable lever via a driving pulley integrated in the switch.

Arc extinction

When closing the switch, the switch blade (5) with the arcing tip (6) is withdrawn from the contact jaw (2). The arc which occurs is extinguished in the enclosed, four-section arcing chamber (4), comprising pressure and expansion chambers. In the pressure chamber two extinguishing plates (3) are forced into the path of the arc by lateral spring pressure.

At low currents the arc is extinguished by deionizing

action due to the cooling effect of the walls. Arc extinction is achieved in the higher current ranges by the arc extinguishing gases produced in the pressure chamber flowing out into the expansion chamber. Due to this rational combination of arc quenching principles the entire current range of the load-break switch is effectively covered.

The arcing chambers require no maintenance.

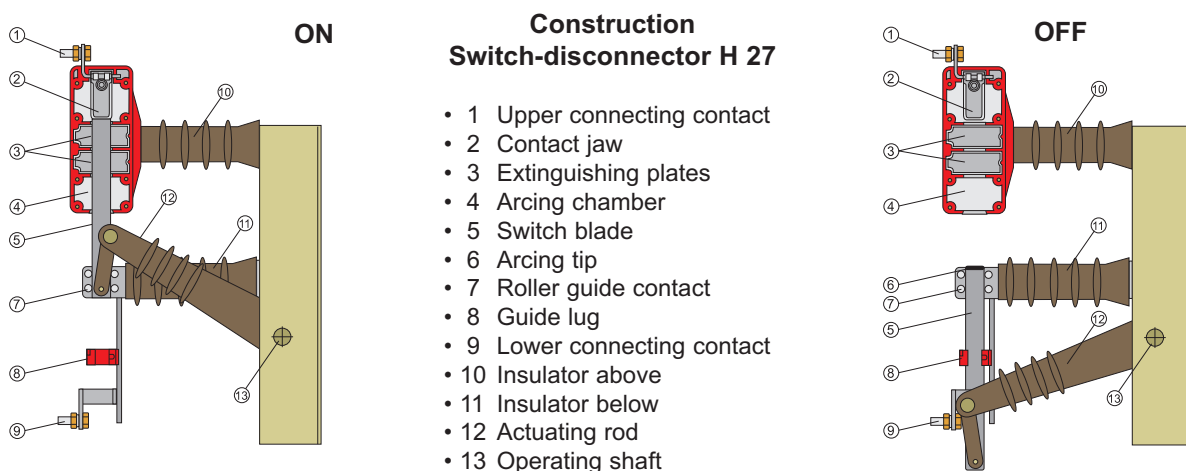

DRIESCHER - Indoor Switch-Disconnecter and Switch-fuse combination H 27

Additional possibilities of mounting, equipment and actuation

All listed additional possibilities of mounting, equipment and actuation devices are optional available and to order separate:

- All types are deliverable with earthing switches mounted below and above.
 - By the types H 27 EK and EA the earthing switch is mounted, so that the earthing switch movement is outside the switch frame.
 - By the type H 27 SEA the earthing switch is mounted, so that the movement of the earthing switch is within the base frame. (No extra space is required, retrofit is possible).
 - By the type H 27 SuT the earthing switch is mounted on a separate insulator cross arm (Retrofit is possible).
For the switch-fuse combination H 27 F-SuT, there is a separate earthing switch with built-in actuating disc to switch with plug-in lever.
- For all types a **mechanical interlocking** between switch-disconnector and earthing switch is possible.
- Shunt releases and tripping magnets can only be mounted on switches with trip-free release (see page 2) and are available for the following voltages: 110 V AC and 230 V AC or 24 V DC, 60 V DC, 110 V DC and 220 V DC.
- Signalling contacts for switch position indication or electrical interlocking can be mounted on all switches - including earthing switches.
- The actuation of the switch-disconnector and the switch-fuse combination H 27 can be performed manually with a plug-in lever or with a motor actuator, see *brochure 774*.
- For information about indoor actuating and equipment for example, insulating rod or pulling lug please see *brochure 774*.
- For further equipment, such as fuse tongs and switchsticks see *brochure 773*.
- For h.v.h.b.c. fuses please see *brochure 791*.

Technical data

according to EN 62271-103

Rated voltage	U_r	kV	12	24
Rated frequency	f_r	Hz	50	50
Rated-(operating)-current	I_r	A	630	630 630
Rated-peak withstand current	I_p	kA	50 ¹⁾	40 ¹⁾ 50 ¹⁾
Rated-short-time current	I_k	kA	20 ¹⁾	16 ¹⁾ 20 ¹⁾
Rated-making current	I_{ma}	kA	50 ¹⁾	40 ¹⁾ 40 ²⁾
Rated-breaking current	I_1	A	630	630 630
Rated-loop breaking current	I_2	A	630	630 630
Rated-transformer off-load breaking current	I_3	A		10
Rated-cable charging breaking current	I_{4a}	A	10	35
Rated-earth fault off-load breaking current	I_{6a}	A	300	320
Rated-cable charging breaking current under earth fault conditions	I_{6b}	A	18	178
Rated-impulse withstand voltage	U_p	kV		
Phase - Phase / Phase - Earth			75	125 ³⁾
across isolating distance			85	145
Rated-power frequency withstand voltage	U_d	kV		
Phase - Phase / Phase - Earth			28	50
across isolating distance			32	60
Electrical class			E1	E1
Mechanical life			M1	M1

1) These values also apply to earthing switches.

2) For mounted earthing switches ES-24-20 the following data is valid:

$$I_k = 20 \text{ kA}, I_{ma} = 50 \text{ kA}, t_k = 3 \text{ s}$$

3) 95 kV for clearance between phases $p = 170 \text{ mm}$ without phase barrier.

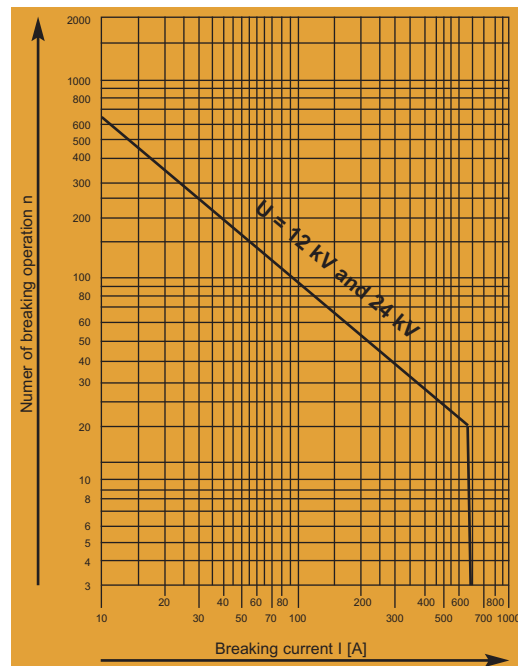

Maintenance-free load breaking operations as a function of the breaking current at $\cos \varphi \geq 0,7$

DRIESCHER - Indoor Switch-Disconnecter H 27

Indoor Switch-Disconnecter H 27 F-EA and F-EK for front-panel mounting

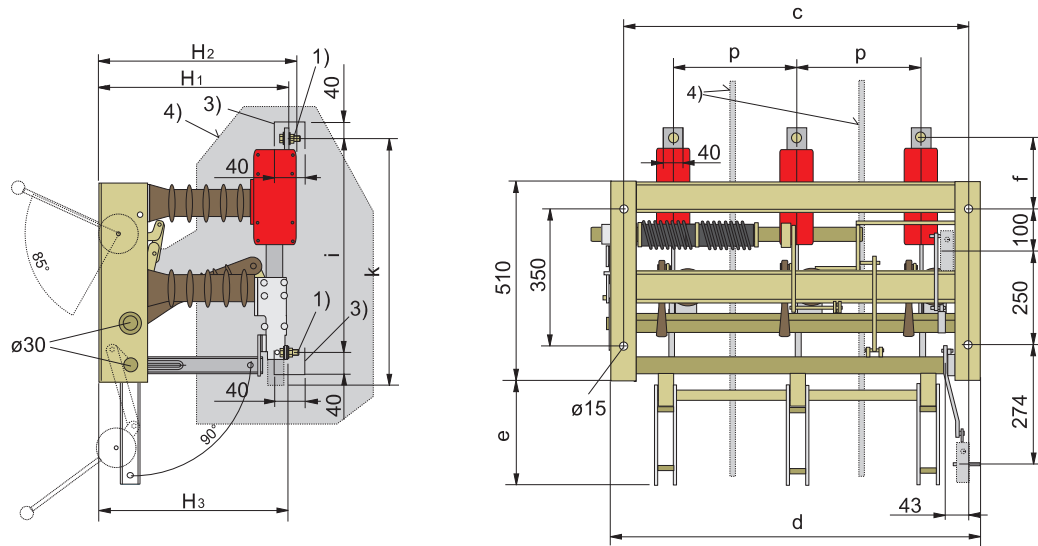

- 1) hexagonal screw M12x40 with two span washers and nut
 3) outside this zone, the connecting bar have to be insulated
 4) phase barriers (only for 24 kV $p = 170$ mm)
 insulation level without phase barriers: UP 95 kV

Fig. 1: Type H 27 F-EA with earthing switch mounted below

Rated voltage U_r	Type	Rated current I_r	Rated-short-time current I_k	p	c	d	e	f	i	k	H_1	H_2	H_3	Drawing-no.
12 kV	H 27 F-EK	630 A	20 kA	155	465	500	117	103	493	545	310	324	314	LN3-093700
12 kV	H 27 F-EA	630 A	20 kA	155	465	500	117	103	493	545	310	324	314	LN3-093699
24 kV	H 27 F-EK	630 A	16 kA	170	495	530	202	186	616	688	385	401	388	LN3-102411
24 kV	H 27 F-EK	630 A	16 kA	225	605	640	202	186	616	688	385	401	388	LN3-102413
24 kV	H 27 F-EK	630 A	20 kA	170	495	530	202	161	591	663	390	406	394	LN4-091398
24 kV	H 27 F-EK	630 A	20 kA	225	605	640	202	161	591	663	390	406	394	LN3-091278
24 kV	H 27 F-EA	630 A	16 kA	170	495	530	202	156	586	663	385	401	388	LN4-041924
24 kV	H 27 F-EA	630 A	16 kA	225	605	640	202	156	586	663	385	401	388	LN4-067888
24 kV	H 27 F-EA	630 A	20 kA	170	495	530	202	161	591	663	390	406	394	LN3-091399
24 kV	H 27 F-EA	630 A	20 kA	225	605	640	202	161	591	663	390	406	394	LN3-091286

Rated voltage U_r	Type	Rated current I_r	Rated-short-time current I_k	without earthing switch			with earthing switch mounted below		
				p	Part-no.	Weight approx. kg	Part-no. without mechanical interlocking	Part-no. with mechanical interlocking	Weight approx. kg
12 kV	H 27 F-EK	630 A	20 kA	155	727 35000	38	727 35011	727 35014	42
12 kV	H 27 F-EA	630 A	20 kA	155	727 36000	38	727 36011	727 36014	42
24 kV	H 27 F-EK	630 A	16 kA	170	727 65150	46	727 65151	727 65154	44
24 kV	H 27 F-EK	630 A	16 kA	225	727 65350	44	727 65352	727 65351	44
24 kV	H 27 F-EK	630 A	20 kA	170	727 75150	46	727 75151	727 75152	51
24 kV	H 27 F-EK	630 A	20 kA	225	727 75350	49	727 75352	727 75351	51
24 kV	H 27 F-EA	630 A	16 kA	170	727 66150	46	727 66151	727 66154	46
24 kV	H 27 F-EA	630 A	16 kA	225	727 66300	48	727 66311	727 66314	54
24 kV	H 27 F-EA	630 A	20 kA	170	727 76150	48	727 76151	727 76154	46
24 kV	H 27 F-EA	630 A	20 kA	225	727 76300	51	727 76311	727 76314	53

DRIESCHER - Indoor Switch-fuse combination H 27

Indoor Switch-fuse combination H 27 F-SuT for front-panel mounting

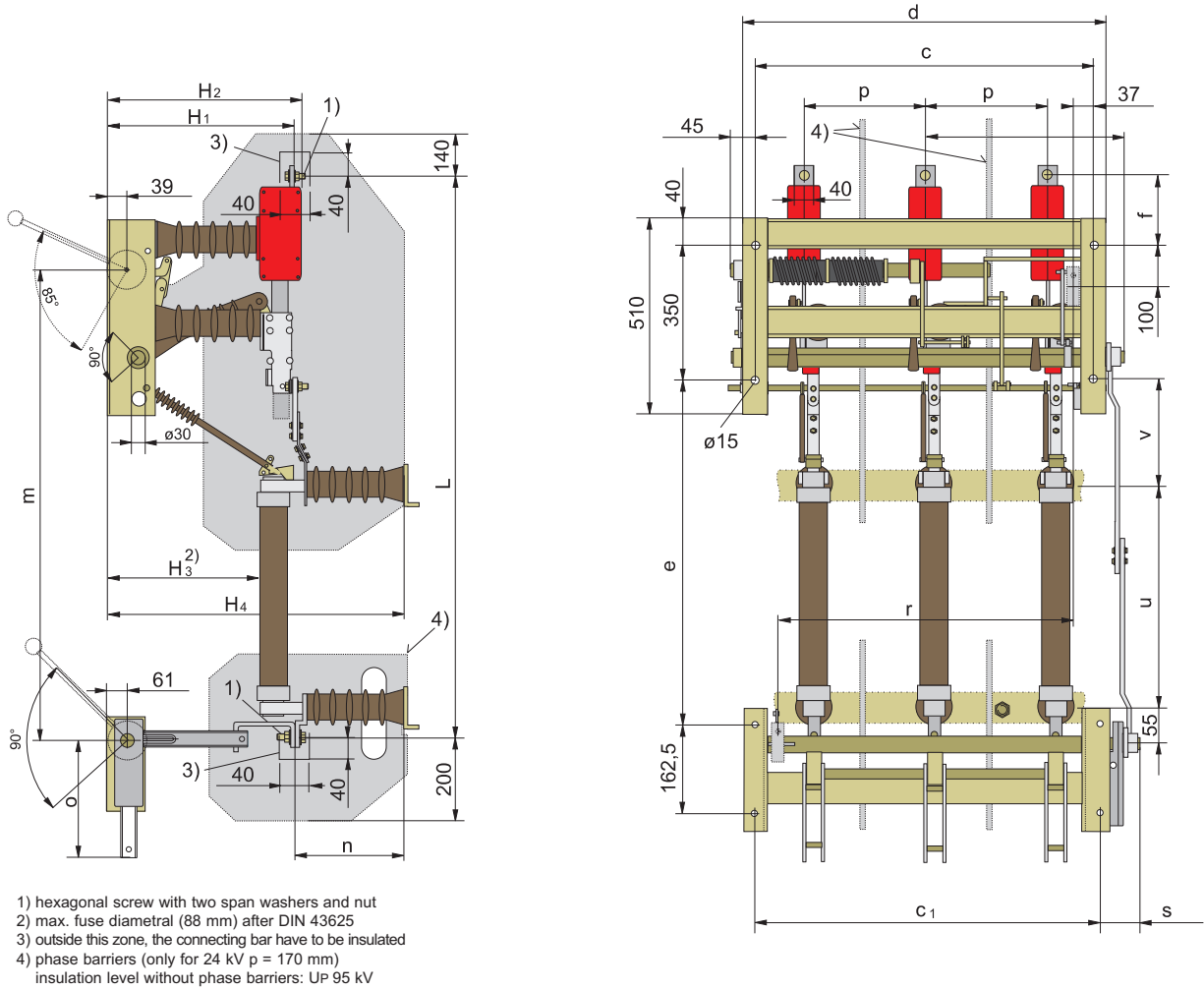

Fig. 2: Type H 27 F-SuT with separate earthing switch mounted below and two separate cross beam for insulators
All-pole disconnection of the switch-disconnector when a fuse operates.

Rated voltage U_r	Type	Rated current ⁶⁾ I_r	Rated-short-time current I_k	p	c	c_1	d	e	f	H_1	H_2	H_3	H_4	L	m	n	o	r	s	u	v
12 kV	H 27 F-SuT	630/125 A	20 kA	155	465	471	500	567	103	310	324	225	472	1047	843	147	204	382	74	325	214
24 kV	H 27 F-SuT	630/125 A	16 kA	170	495	491	530	751	186	385	401	299	626	1291	1027	227	280	412	42	475	240
24 kV	H 27 F-SuT	630/125 A	16 kA	225	605	651	640	751	186	385	401	299	626	1291	1027	227	280	412	42	475	240

Rated voltage U_r	Type	Rated current ⁶⁾ I_r	Rated-short-time current I_k	p	without earthing switch		with earthing switch below		Weight approx. kg	Drawing-no.
					Part-no.	Weight approx. kg	Part-no. without mechanical interlocking	Part-no. with mechanical interlocking		
12 kV	H 27 F-SuT	630/125 A	20 kA	155	727 37100	58	727 37111 *	727 37111 **	64	LN3-093701
24 kV	H 27 F-SuT	630/125 A	16 kA	170	727 67150	64	727 67171 *	727 67171 **	70	LN3-102412
24 kV	H 27 F-SuT	630/125 A	16 kA	225	727 67350	69	727 67351 *	727 67351 **	75	LN3-102414

* with separate earthing switch
** with separate earthing switch and interlocking
6) Rated current of the fuse holder 125 A

DRIESCHER - Indoor Switch-Disconnecter H 27

Indoor Switch-Disconnecter H 27 EK and EA for wall mounting

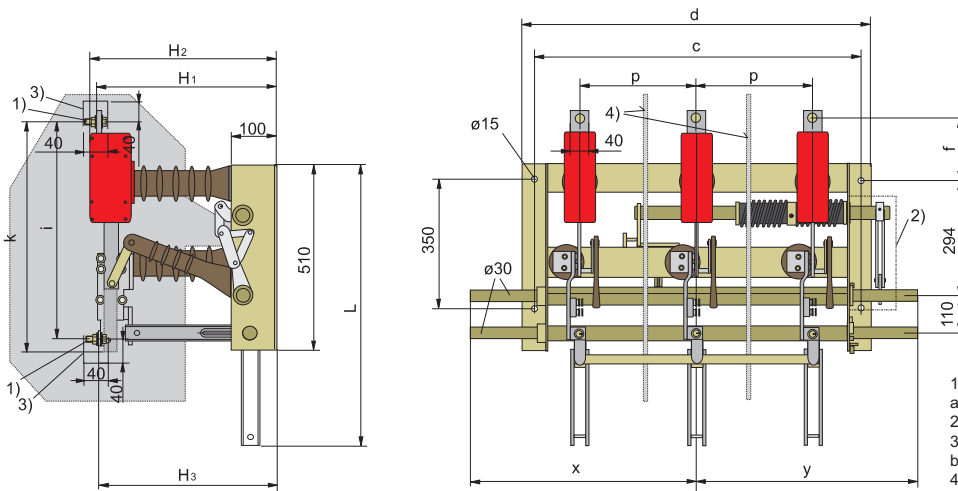

Fig. 3: Type H 27 EA
with
earthing switch
mounted below

- 1) hexagonal screw with two span washers and nut
2) covering
3) outside this zone, the connecting bar have to be insulated
4) phase barriers (only for 24 kV p = 170 mm) insulation level without phase barriers: UP 95 kV

Rated voltage U_r	Type	Rated current I_r	Rated-short-time current I_k	p	c	d	f	H_1	H_2	H_3	i	k	L	x	y
12 kV	H 27 EK	630 A	20 kA	155	465	500	103	310	324	314	493	545	627	290	290
12 kV	H 27 EK	630 A	20 kA	210	575	610	103	310	324	314	493	545	627	450	450
12 kV	H 27 EA	630 A	20 kA	155	465	500	103	310	324	314	493	545	627	290	290
12 kV	H 27 EA	630 A	20 kA	210	575	610	103	310	324	314	493	545	627	450	450
24 kV	H 27 EK	630 A	16 kA	170	495	530	156	385	401	388	586	658	712	460	460
24 kV	H 27 EK	630 A	20 kA	170	495	530	161	390	406	394	591	663	712	460	460
24 kV	H 27 EK	630 A	16 kA	225	605	640	161	385	399	388	551	663	712	440	440
24 kV	H 27 EK	630 A	20 kA	225	605	640	161	390	406	394	591	669	712	440	440
24 kV	H 27 EK	630 A	16 kA	275	705	740	161	385	399	388	591	663	712	565	565
24 kV	H 27 EK	630 A	20 kA	275	705	740	161	390	404	394	591	669	712	565	565
24 kV	H 27 EA	630 A	16 kA	170	495	530	156	385	401	388	586	658	712	460	460
24 kV	H 27 EA	630 A	20 kA	170	495	530	161	390	406	394	591	669	712	460	460
24 kV	H 27 EA	630 A	16 kA	225	605	640	156	385	401	388	586	663	712	440	440
24 kV	H 27 EA	630 A	20 kA	225	605	640	161	390	406	394	591	663	712	440	440
24 kV	H 27 EA	630 A	16 kA	275	705	740	161	385	399	388	591	663	712	565	565
24 kV	H 27 EA	630 A	20 kA	275	705	740	161	390	406	394	591	663	712	565	565

Rated voltage U_r	Type	Rated current I_r	Rated-short-time current I_k	p	without earthing switch		with earthing switch mounted below		Weight approx. kg	Drawing-no.
					Part-no.	Weight approx. kg	Part-no. without mechanical interlocking	Part-no. with mechanical interlocking		
12 kV	H 27 EK	630 A	20 kA	155	727 31100	34	727 31111	727 31114	39	LN3-093697
12 kV	H 27 EK	630 A	20 kA	210	727 31400	41	727 31411	727 31414	46	LN3-093703
12 kV	H 27 EA	630 A	20 kA	155	727 32100	34	727 32111	727 32114	39	LN3-093696
12 kV	H 27 EA	630 A	20 kA	210	727 32400	41	727 32411	727 32414	46	LN3-093702
24 kV	H 27 EK	630 A	16 kA	170	727 61515	38	727 61511	727 61516	44	LN3-091502
24 kV	H 27 EK	630 A	20 kA	170	727 71500	38	727 71511	727 71514	44	LN3-091503
24 kV	H 27 EK	630 A	16 kA	225	727 61350	45	727 61311	727 61300	51	LN3-106043
24 kV	H 27 EK	630 A	20 kA	225	727 71300	45	727 71311	727 71314	51	LN4-067886
24 kV	H 27 EK	630 A	16 kA	275	727 61151	40	727 61152	727 61153	46	LN3-102801
24 kV	H 27 EK	630 A	20 kA	275	727 71100	48	727 71111	727 71114	54	LN3-102803
24 kV	H 27 EA	630 A	16 kA	170	727 62500	40	727 62511	727 62514	46	LN3-091504
24 kV	H 27 EA	630 A	20 kA	170	727 72500	47	727 72511	727 72514	53	LN3-091505
24 kV	H 27 EA	630 A	16 kA	225	727 62302	48	727 62301	727 62300	58	LN4-067884
24 kV	H 27 EA	630 A	20 kA	225	727 72300	51	727 72311	727 72314	62	LN3-091543
24 kV	H 27 EA	630 A	16 kA	275	727 62151	51	727 62153	727 62152	62	LN4-039597
24 kV	H 27 EA	630 A	20 kA	275	727 72100	53	727 72101	727 72111	65	LN3-091501

DRIESCHER - Indoor Switch-fuse combination H 27

Indoor Switch-fuse combination H 27 SEA for wall mounting

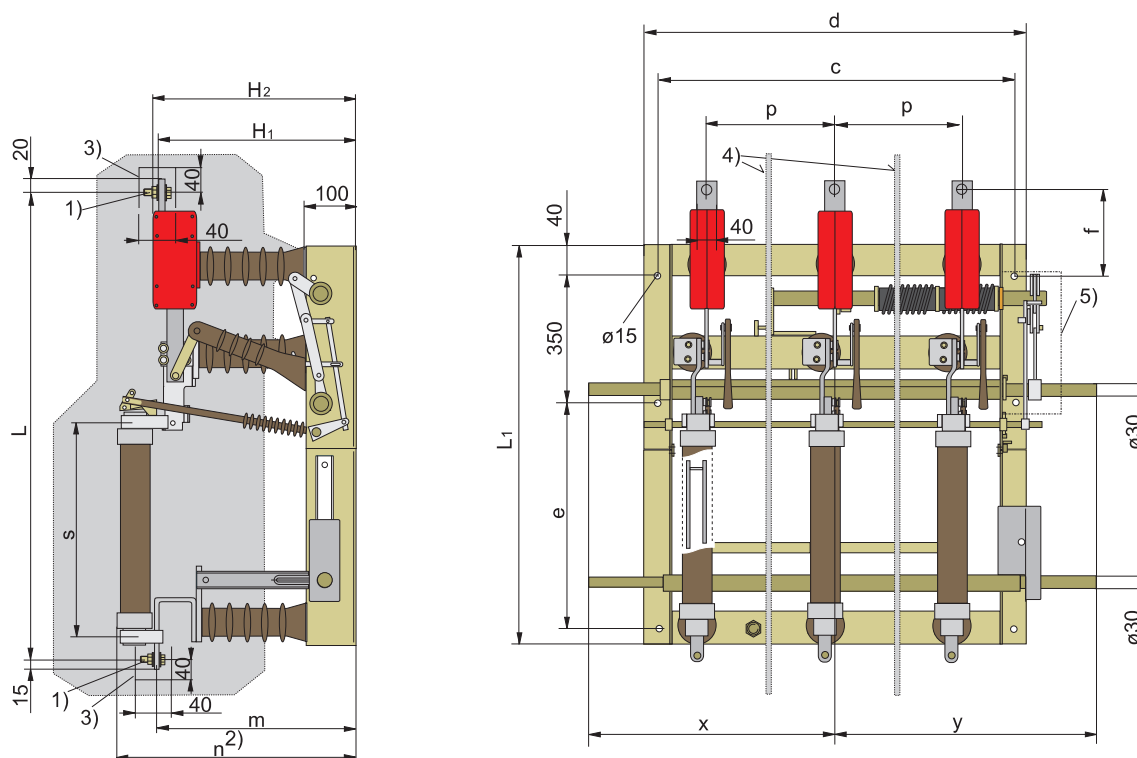

- 1) hexagonal screw with two span washers and nut
- 2) max. fuse diametral (88 mm) after DIN 43625
- 3) outside this zone, the connecting bar have to be insulated
- 4) phase barriers (only for 24 kV $p = 170$ mm)
insulation level without phase barriers: UP 95 kV
- 5) covering

Fig. 4: Type H 27 SEA with earthing switch mounted below
All-pole disconnection of the switch-disconnector when a fuse operates.

Rated voltage U_r	Type	Rated current ⁶⁾ I_r	Rated-short-time current I_k	p	c	d	e	f	H_1	H_2	L	L_1	m	n	s	x	y
12 kV	H 27 SEA	630/125 A	20 kA	155	465	500	500	103	310	324	1013	925	254	354	325	340	340
12 kV	H 27 SEA	630/125 A	20 kA	210	575	610	500	103	310	324	1013	925	254	343	325	450	450
24 kV	H 27 SEA	630/125 A	16 kA	170	495	530	478	156	385	401	1040	903	388	493	475	460	460
24 kV	H 27 SEA	630/125 A	16 kA	225	605	640	478	156	385	401	1040	903	388	493	475	440	440
24 kV	H 27 SEA	630/125 A	16 kA	275	705	740	478	161	385	401	1045	903	388	493	475	565	565

Rated voltage U_r	Type	Rated current ⁶⁾ I_r	Rated-short-time current I_k	p	without earthing switch		with earthing switch mounted below			Drawing-no.
					Part-no.	Weight approx. kg	Part-no. without mechanical interlocking	Part-no. with mechanical interlocking	Weight approx. kg	
12 kV	H 27 SEA	630/125 A	20 kA	155	727 33852	44	727 33861	727 33864	51	LN3-095549
12 kV	H 27 SEA	630/125 A	20 kA	210	727 33870	51	727 33871	727 33874	60	LN3-095849
24 kV	H 27 SEA	630/125 A	16 kA	170	727 63500	61	727 63511	727 63514	68	LN3-090676
24 kV	H 27 SEA	630/125 A	16 kA	225	727 63302	64	727 63301	727 63300	74	LN4-067885
24 kV	H 27 SEA	630/125 A	16 kA	275	727 63151	68	727 63152	727 63153	79	LN4-039598

⁶⁾ Rated current of the fuse holder 125 A

DRIESCHER - Indoor Switch-Disconnecter H 27

Indoor Switch-Disconnecter H 27 EA and EK for lateral mounting

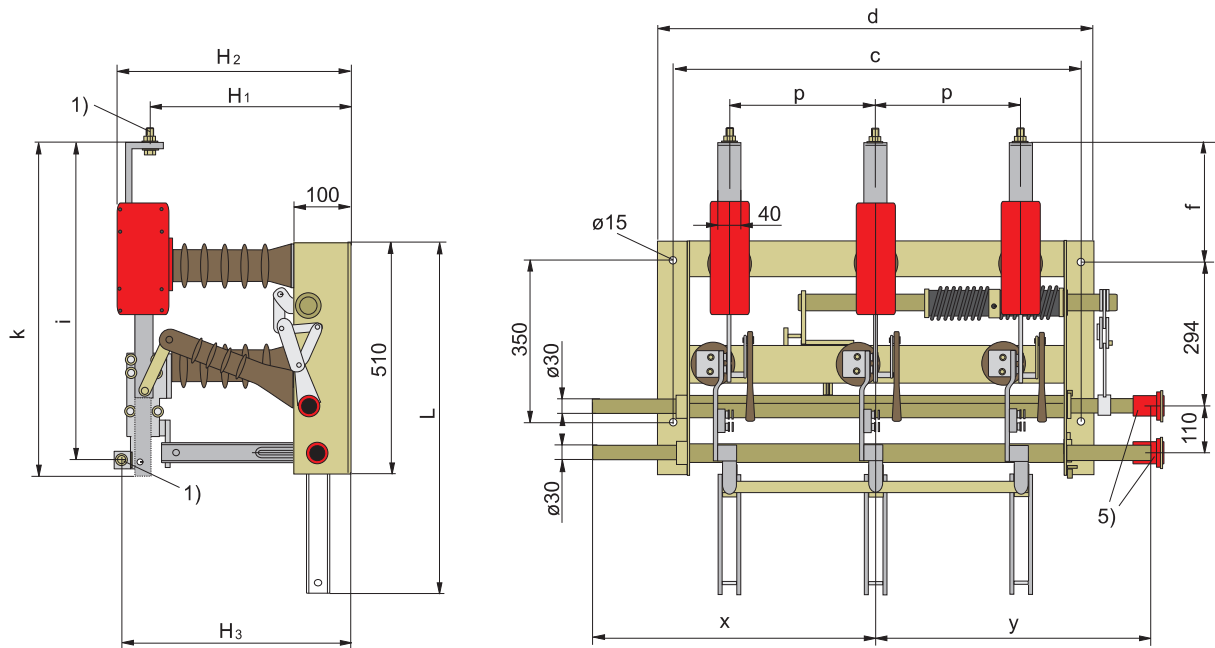

- 1) hexagonal screw with two span washers and nut
 5) drive box and clamping washer with ON / OFF indicator

Fig. 5: Type H 27 EA with earthing switch mounted below

Rated voltage U_r	Type	Rated current I_r	Rated-short-time current I_k	p	c	d	f	H_1	H_2	H_3	i	k	L	x	y	Drawing-no.
12 kV	H 27 EK	630 A	20 kA	155	465	500	197	310	324	314	587	639	627	287	398	LN3-095031
24 kV	H 27 EK	630 A	16 kA	275	705	740	255	360	399	361	685	757	712	513	513	LN3-102802
24 kV	H 27 EK	630 A	20 kA	275	705	740	255	365	404	365	685	763	712	513	513	LN3-102804
24 kV	H 27 EA	630 A	16 kA	275	705	740	255	360	401	358	685	763	712	513	513	LN4-044887
24 kV	H 27 EA	630 A	20 kA	275	705	740	255	360	406	375	685	757	712	513	513	LN3-091500

Rated voltage U_r	Type	Rated current I_r	Rated short-time current I_k	p	without earthing switch		with earthing switch mounted below		
					Part-no.	Weight approx. kg	Part-no. without mechanical interlocking	Part-no. with mechanical interlocking	Weight approx. kg
12 kV	H 27 EK	630 A	20 kA	155	727 31190	42	727 31294	727 31292	53
24 kV	H 27 EK	630 A	16 kA	275	727 61201	51	727 61203	727 61204	62
24 kV	H 27 EK	630 A	20 kA	275	727 71171	48	727 71175	727 71950	59
24 kV	H 27 EA	630 A	16 kA	275	727 62271	50	727 62211	727 62215	61
24 kV	H 27 EA	630 A	20 kA	275	727 72201	53	727 72203	727 72205	64

DRIESCHER - Indoor Switch-fuse combination H27

Indoor Switch-fuse combination H 27 SuT for lateral mounting

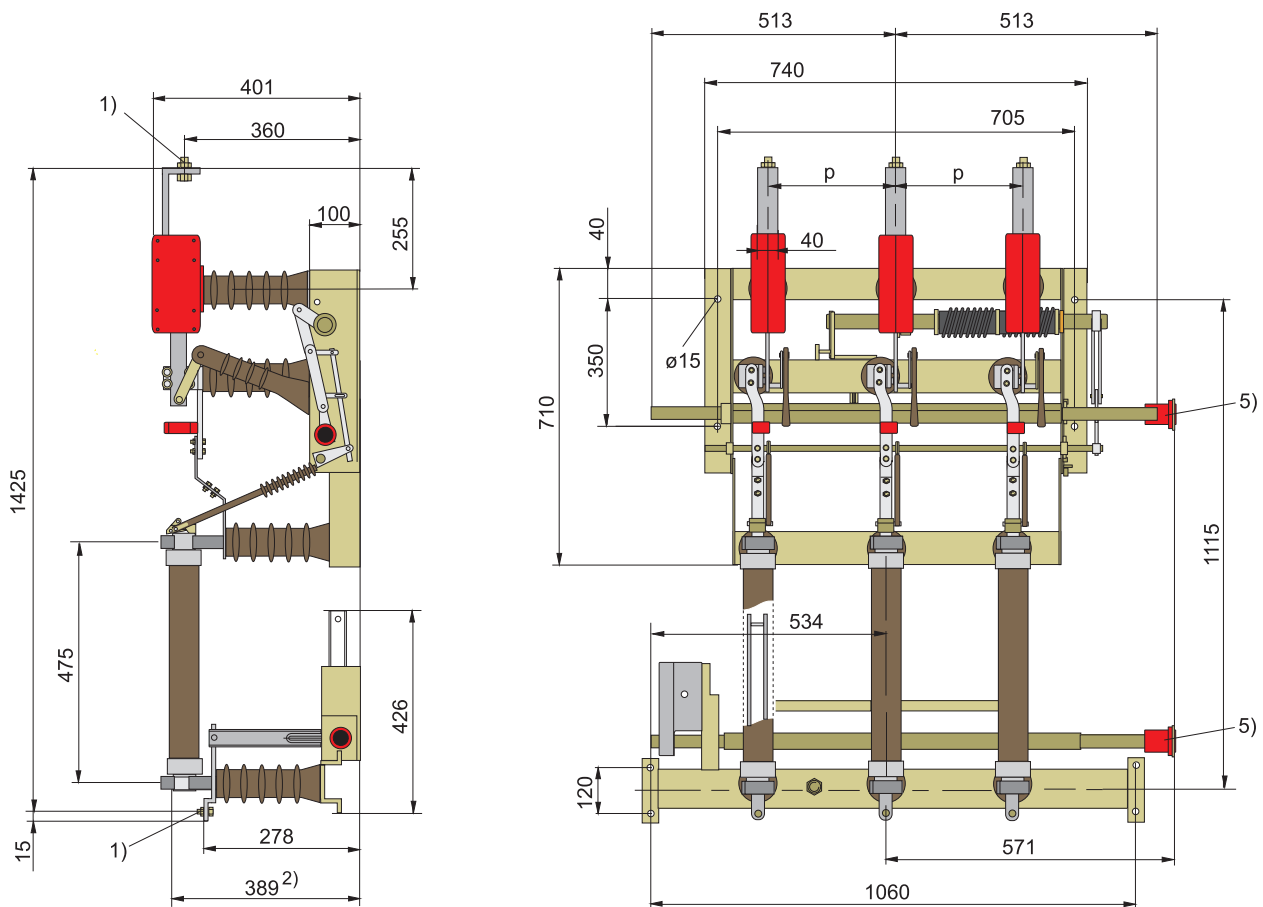

- 1) hexagonal screw with two span washers and nut
 2) max. fuse diameter (88 mm) after DIN 43625
 5) drive box and clamping washer with ON / OFF indicator

Fig. 6: Type H 27 SuT with earthing switch mounted below and separate cross rail with mounted insulators

All-pole disconnection of the switch-disconnector when a fuse operates.
 HV HBC-fuses are removable laterally !

Rated voltage U_r	Type	Rated current ⁶⁾ I_r	Rated-short-time current I_k	p	without earthing switch			Drawing-no.
					Part-no. switch	Part-no. cross rail	Weight approx. kg	
24 kV	H 27 SuT	630/125 A	16 kA	275	727 63001	720 72104	74	LN4-44233

Rated voltage U_r	Type	Rated current ⁶⁾ I_r	Rated-short-time current I_k	p	with earthing switch mounted below		Weight approx. kg
					Part-no. without mechanical interlocking	Part-no with mechanical interlocking	
24 kV	H 27 SuT	630/125 A	16 kA	275	on request *	on request **	88

- * with separate earthing switch
 ** with separate earthing switch and interlocking
 6) Rated current of the fuse holder 125 A

DRIESCHER - Indoor Switch-fuse combination H 27

Indoor Switch-fuse combination H 27 SEA for lateral mounting

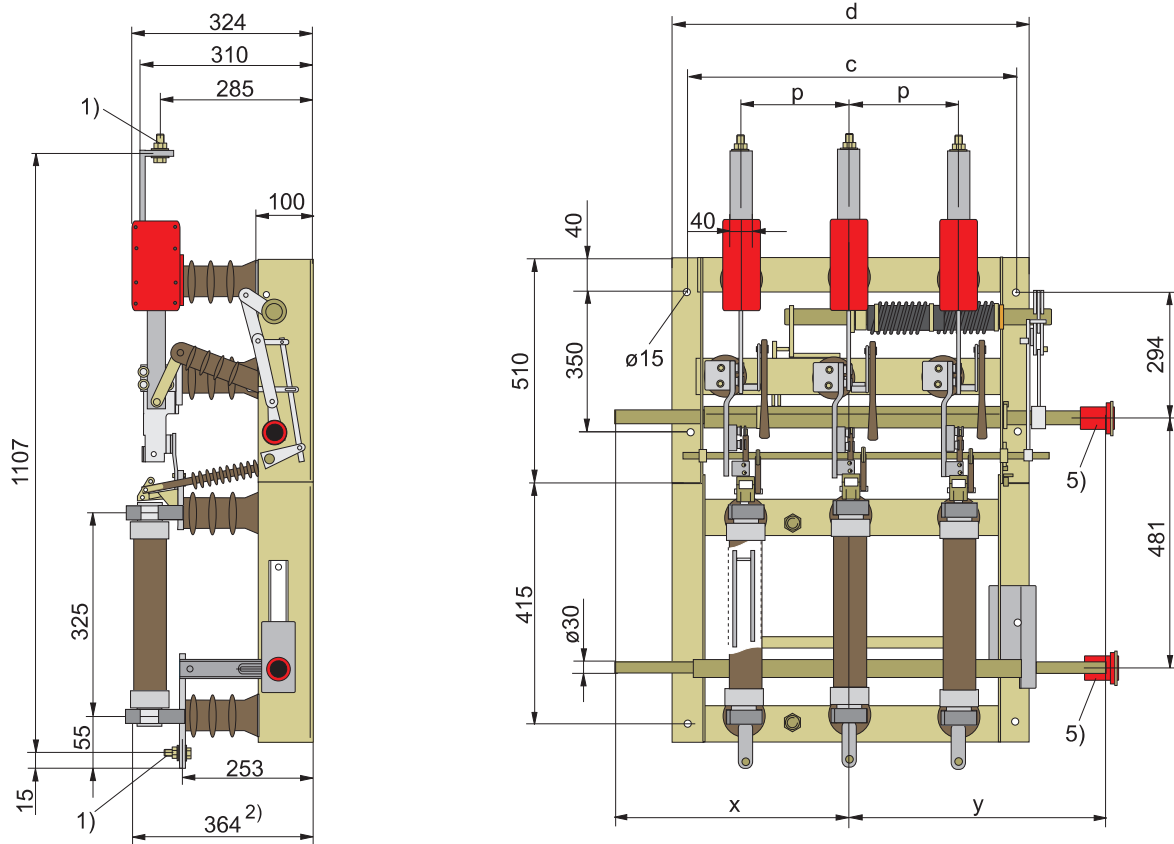

- 1) hexagonal screw with two span washers and nut
 2) max. fuse diametral (88 mm) after DIN 43625
 5) drive box and clamping washer with ON / OFF indicator

Fig. 7: Type H 27 SEA with earthing switch mounted below

All-pole disconnection of the switch-disconnector when a fuse operates.
 HV HBC-fuses are removable laterally !

Rated voltage U_r	Type	Rated current ⁶⁾ I_r	Rated-short-time current I_k	p	c	d	x	y	without earthing switch		Drawing-no.
									Part-no.	Weight approx. kg	
12 kV	H 27 SEA	630/125 A	20 kA	155	465	500	287	398	727 33295	61	LN3-094869
12 kV	H 27 SEA	630/125 A	20 kA	210	575	610	450	450	727 33490	68	LN3-107771

Rated voltage U_r	Type	Rated current ⁶⁾ I_r	Rated-short-time current I_k	p	with earthing switch mounted below		Weight ca. kg
					Part-no. without mechanical interlocking	Part-no with mechanical interlocking	
12 kV	H 27 SEA	630/125 A	20 kA	155	727 33692	727 33297	77
12 kV	H 27 SEA	630/125 A	20 kA	210	727 33492	727 33494	86

⁶⁾ Rated current of the fuse holder 125 A

Type Switch-fuse combination H 27

These switch-fuse combinations according to EN 62271-105 comprise a functional unit of switch disconnectors according to EN 62271-103 and back-up fuses according to EN 60282-1.

Switch-fuse combinations are used for switching on and off of distribution transformers in secondary substations. They additionally have the task of protecting these transformers against the impact of internal and external faults.

By means of the fuses the breaking capacity of the combination is extended beyond that of a simple

switch disconnector up to the rated short-circuit breaking current of the fuse.

The high-voltage high breaking capacity fuse, according to the statistics of the VDN (German Association of Electricity Network Operators) offers a reliable transformer protection. The h.v.h.b.c. fuse in combination with a switch disconnector provides a simple solution which is very economical and practical to procure and run.

This provides a clear advantage over a circuit breaker with the associated current transformers and overcurrent time protection.

Recommended protection for DRIESCHER - Switch-fuse combination in accordance with EN 62271-105

High-voltage high breaking capacity fuse link for $U_r = 12 \text{ kV}$ and 24 kV

Rated- transformer- power [kVA]	Fuse Type STA and Type SSK			
	Rated current of the h.v.h.b.c. fuse			
	Rated voltage U_r			
	12 kV Fitting dimensions of fuses $e = 292 \text{ mm}$		24 kV Fitting dimensions of fuses $e = 442 \text{ mm}$	
	min. (A)	max. (A)	min. (A)	max. (A)
50	6,3	6,3	6,3	6,3
80	10	10	6,3	6,3
100	10	16	6,3	10
125	16	20	10	16
160	20	25	10	20
200	25	31,5	16	20
250	31,5	40	16	25
315	31,5	50	20	25
400	40	50	25	31,5
500	50	63	25	40
630	63		31,5	50
800	80, Type SSK		40	50
1000	100, Type SSK		50	63
1250	125, Type SSK and tripping delay*		63	
1600			80	
2000			100, Type SSK and tripping delay*	
2500			125, Type SSK and tripping delay*	

* Time of tripping delay of the switch: $U_r 12 \text{ kV}$ 250 ms +0/-50 ms
 $U_r 24 \text{ kV}$ 500 ms +0/-50 ms

Suitable fuses: Type **STA** DRIESCHER Moosburg and Type **SSK** Siba Lünen

Dimensions, weights, diagrams and descriptions in this brochure are non-binding. Subject to change without notice.

STROM • SICHER • SCHALTEN

ELEKTROTECHNISCHE WERKE
FRITZ DRIESCHER & SÖHNE GMBH

D-85366 Moosburg • Phone: +49 8761 681-0 • Fax: +49 8761 681-137
www.driescher.com info@service@driescher.de

