

**Operating and  
maintenance instructions  
for DRIESCHER  
Outdoor Switch-Disconnectors**

- Type FLa 15/60
- Type FLa 15/6400
- Type FLa 15/6410, FLa 15/6410 SA



FLa

**ELEKTROTECHNISCHE WERKE  
FRITZ DRIESCHER & SÖHNE GMBH**

85366 Moosburg • Tel.: +49 8761 681-0 • Fax: +49 8761 681-137  
www.driescher.de info@service@driescher.de



## DRIESCHER Outdoor Load-Break Switch FLa

in accordance with EN 62271-103

### Table of contents

• 2	Transport and storage, Connecting of switches, Assembly instructions
• 3	Assembly instructions for FLa 15/6400 - FLa 15/6410 mounted to a concrete column
• 4	Assembly instructions for single-pole FLa 15/60 mounted to a concrete column
• 6	Assembly instructions for FLa 15/60 mounted to a common base frame, auxiliary switch
• 8	Inspection, Maintenance, Repair

### Transport and storage

After receipt of delivery, please unpack switchgear carefully, and check for any damage incurred during transit. If any damage is detected, please report immediately, and notify the shipping company thereof. After unpacking, any remnants of wrapping materials should

be cleaned off the units and accessories. Until their installation, these should be protected from damage, humidity, and soiling. For handling, the switches should be taken up by their frame only, and under no circumstances by their vacuum poles.

### Operating conditions

Installation can be carried out at heights of up to 1000 m above sea level. At heights above 1000 m the rated insulating level of the switchgear must be corrected accordingly.

The switches are designed for normal operating conditions according to EN 62271-1.

According to this the following limiting values applies:

Ambient temperature:

Peak value of the ambient temperature +40°C

Average value over 24 hours +35°C

Min. value of the ambient temperature - 40°C  
(class "minus 40 Outdoor")

### Commissioning

Before mounting on the concrete column the stopper screws on the case of the switching chamber should be removed, the oil level must be checked

(0,5 Liter Shell Diala D oil, see maintenance instructions) and the provided ventilating plug must be screwed in.

### Connecting of switches

#### Conductor bars, or cable sealing ends

Please make sure that switch terminals are not twisted. Neither transverse nor tensile nor torsional force should be applied to the switch terminals.

The M 12 terminal screws should be tightened using a torque of 70 Nm (with a second spanner used for countering). Particular attention should be paid to the requirement that electrical clearances should not be less than those specified, and that the mobility of the rotary post insulator should not be impaired.

#### Preparation of earth connections

The frame contains the appropriate boreholes for holding the M 12 earth-connection screw. The minimum cross section of the earth-connection terminal leads should be 50 mm<sup>2</sup>.

If assembly is carried out on an earthed supporting structure, the necessary earth connection may already be provided with the mounting of the unit if the appropriate contact washers are used.

### Assembly instructions for FLa 15/6400 / 6410 mounted to a concrete column

#### A With single box-type actuator or L-actuator

1. On its conduit section ②, the L-actuator ① has a threaded coupling for connecting the lower linkage rod. For the box-type actuator ⑦, mounting is carried out through the bushing contained in the actuator tube.
2. As a rule, actuators are arranged at 90° laterally to

the switch (the crank of the actuator shaft is fastened outside the centre of the switch).

3. In this arrangement, a reversible bearing, type 17131 ③, serves as the up-permost guide and, simultaneously, for reversing the direction of thrust. Fastening to the column is carried out using two M 16 x 100 screws.

Assembly instructions for FLa 15/6400 / 6410 / SA mounted to a concrete column

4. Depending on the length of the column, the linkage rod is guided using 1 or 2 intermediate (4) bearings. The intermediate bearing (3) preceding the reversible bearing is provided with a link bushing which enables the linkage rod to deflect sideways. This intermediate bearing is marked with a red label. Fastening to the column is carried out in the same way as for the reversible bearing.
5. The distance between the bottom and the centre of the actuator box, or mechanism assembly, should be 1250 mm if possible.
6. It is to be recommended that actuators should be mounted with the column in horizontal position.
7. Setting of the operating mechanism must be carried out with the switch in closed position.
8. Any tensions within the linkage are to be compensated for by loosening the clamps on the stub heads (5).
9. The boreholes in the clamp-on (6) crank provide a possibility of setting the operating path (cf. illustration, crank position).
10. When fixing switches in place please make sure that frames are not distorted by uneven surfaces. If

appropriate, use a backing to compensate for unevenness.

11. The switches have been designed so as to ensure that there is no need for linkage crimping. The switch has been set correctly if it reaches the ON and OFF positions even when the actuator is being operated slowly in both directions.
12. After several trial switching operations, all terminal and fixing screws, including those for clamping stub heads and clamp-on cranks, must be re-tightened.

**B Concrete column with dual box-type actuator**

1. For operating these switches with attached earthing switch, a dual box-type actuator is used (7). The operating levers are mechanically interlocked with each other within the box. Any inadvertent wrong operation is thereby ruled out.
2. The dual intermediate bearing provided (8) with a link bushing (marked with a red label) guides the linkage mechanism.

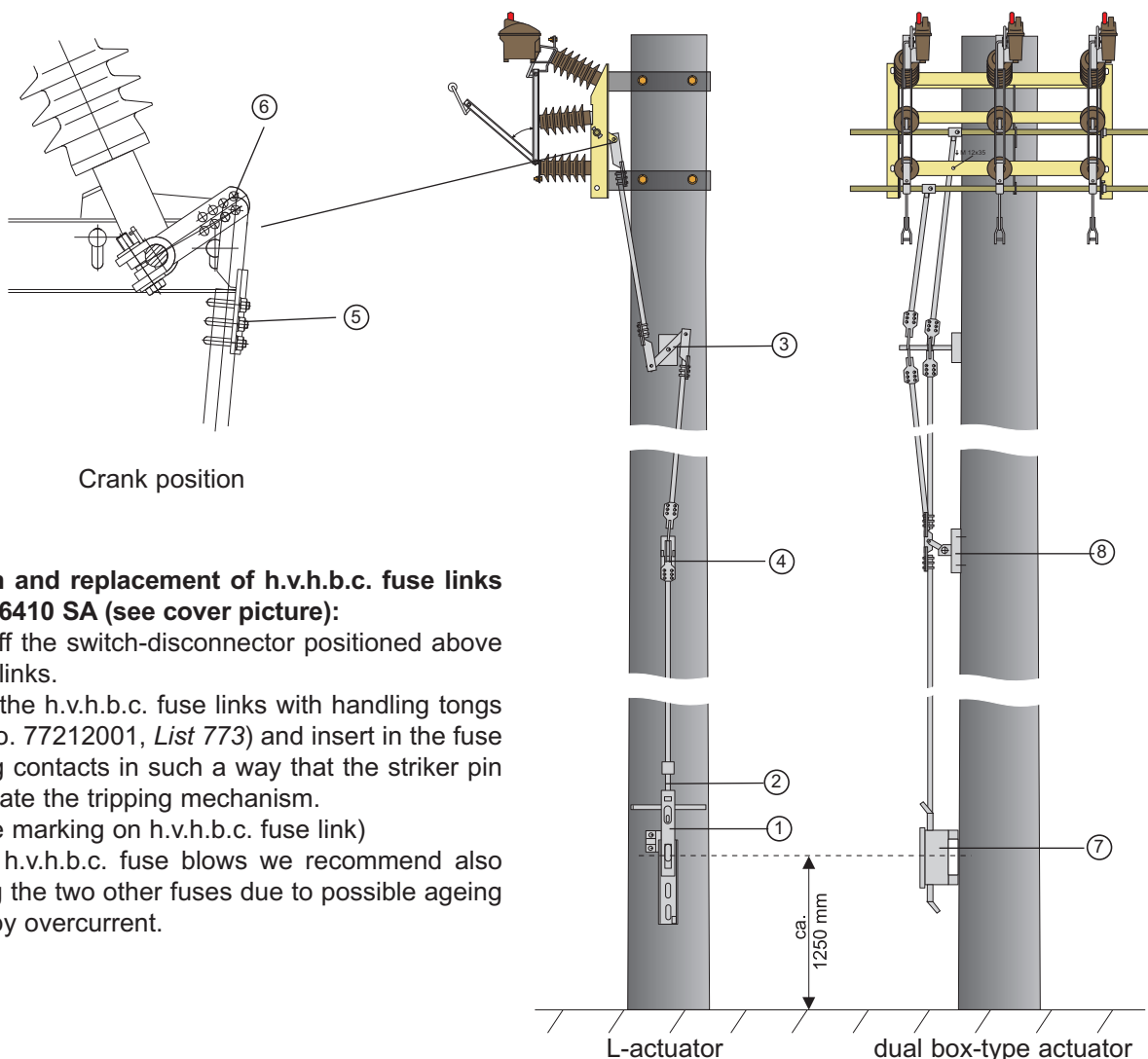

**Insertion and replacement of h.v.h.b.c. fuse links Type 15/6410 SA (see cover picture):**

Switch off the switch-disconnector positioned above the fuse links.

Take up the h.v.h.b.c. fuse links with handling tongs (Order no. 77212001, List 773) and insert in the fuse mounting contacts in such a way that the striker pin can operate the tripping mechanism. (Observe marking on h.v.h.b.c. fuse link)

When a h.v.h.b.c. fuse blows we recommend also replacing the two other fuses due to possible ageing caused by overcurrent.

### A Breaker poles (for wide-spanned systems)

The breaker poles are each marked with a date and a number. Please make sure that in each case only 3 poles marked with the same date and the same number are assembled.

The 3 single poles are preassembled, i.e., mounted to the cross arm of the column using 4 M 16 x 45 hexagonal screws each, and connected to the 2 coupling shafts.

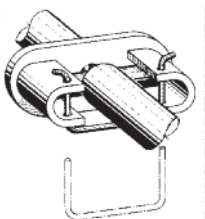

In order to prevent the coupling shafts from falling out of the coupling sleeves, the securing clips included in the scope of delivery must be attached.

**Any unevenness in the cross arms of the columns should by all means be compensated for by using washers.**

Prior to setting the operating mechanism, the single poles shall be attached finally, in true alignment, to the cross arms of the column.

### B Box-type actuators (travel, 140 mm)

1. The FLA 15/60 outdoor load-break switch without earthing switch is operated using a single box-type actuator ①.

The actuator tube used for this purpose contains a bushing for fastening in the actuator box.

2. Actuator box and linkage mechanism should always be arranged at 90° to the cable run.
3. The actuator box is attached to the concrete column using 4 M 16 x 100 hexagonal screws. The boreholes used for fastening will be accessible after the lid has been opened.
4. For guiding the linkage ④, ⑤, ⑥, 2 or more intermediate bearings ②, ③ should be placed, depending on the length of the column.  
For fastening the intermediate bearings, 2 M 16 x 100 hexagonal screws are required.
5. In the single stub head of the upper intermediate bearing ③, there is a link bushing which enables the linkage rod to deflect sideways. That intermediate bearing is marked with a red label.
6. The clamp-on crank ⑧ is mounted to the shaft of the switch between the pole frame and the support bearing ⑨. If no support bearing is used, the clamp-on crank should be mounted as closely as possible to the centre of the pole frame.
7. For hinging the linkages, illustrations ①a, ①b, ①c, as well as positions ⑦, ⑧ should be observed.

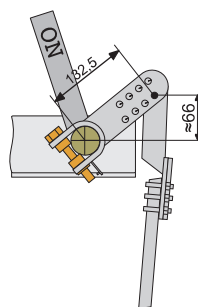

Settings for 24 kV and 36 kV load-break switches

8. Setting the actuator may be carried out with the switch in ON position only.  
If the operating mechanism is set prior to guying the overhead conductors, re-adjustment of the operating mechanism after guying will be absolutely necessary.
9. The upper linkage rod ⑥ with the clamping stub head ⑦ is to be connected with the clamp-on crank ⑧.
10. The switch will be adjusted correctly if it reaches the ON and OFF positions even if the actuator is being operated slowly in both directions.  
The end stops for the ON and OFF positions have been marked in a clearly visible manner on each switch.
11. Any tension in the linkage should be compensated for by loosening the clamping stub heads of the intermediate bearings, with nuts to be retightened the reafter.
12. After several trial switching operations, all terminal and fixing screws, including those for clamping stub heads and clamp-on cranks, must be retightened.  
For operating outdoor load-break switches, dual and triple-box actuators are used with one or two earthing switches attached (cf. illustrations ①b and ①c).
13. The clamp-on cranks ⑧ are also to be fastened to the earthing-switch shafts, as closely as possible to the centre of the pole frame. For central switch poles mounted to sub-frames, earthing-switch shafts are on the fixed-mounted post-insulator side connected mechanically to an intermediate shaft positioned in the subframe. The clamp-on crank ⑧ is attached to that intermediate shaft.
14. For hinging the linkages, illustrations ①a, ①b, ①c as well as ⑦, ⑧ positions should be observed.

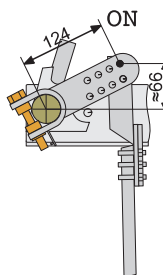

Settings for earthing switches on the 24 kV fixed-mounted post-insulator

Assembly instructions for single-pole FLA 15/97 mounted to a concrete column

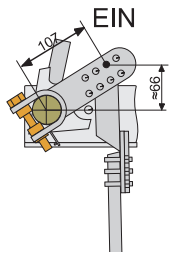

Settings for earthing switches on the 36 kV fixed-mounted post-insulator side

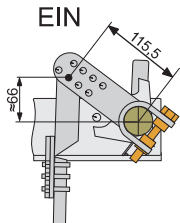

Settings for earthing switches on 24 kV and 36 kV on the rotary post-insulator side

Setting the actuators is carried out with the earthing switches in ON position. For that purpose, the load-break switch must be set to the OFF position before. The setting procedure to be followed is the same as under **B 9** to **12**.

Special-purpose accessories

Shaft support bearings ⑨ are to be mounted on the actuator side to the cross arm, using 2 M 16 x 45 hexagonal screws. The actuator shaft of the central switch pole must not be warped. Differences in height are to be compensated for by end shields guided in elongated holes.

Sub-frames

1. Sub-frames are ex factory mounted below the frames mes of the switch poles. A sub-frame is fastened to the cross arm of a column using 4 M 16 x 45 hexagonal screws.
2. The fastening procedure to be followed is the same as under **A**.

Arrangement of single, dual and triple actuators

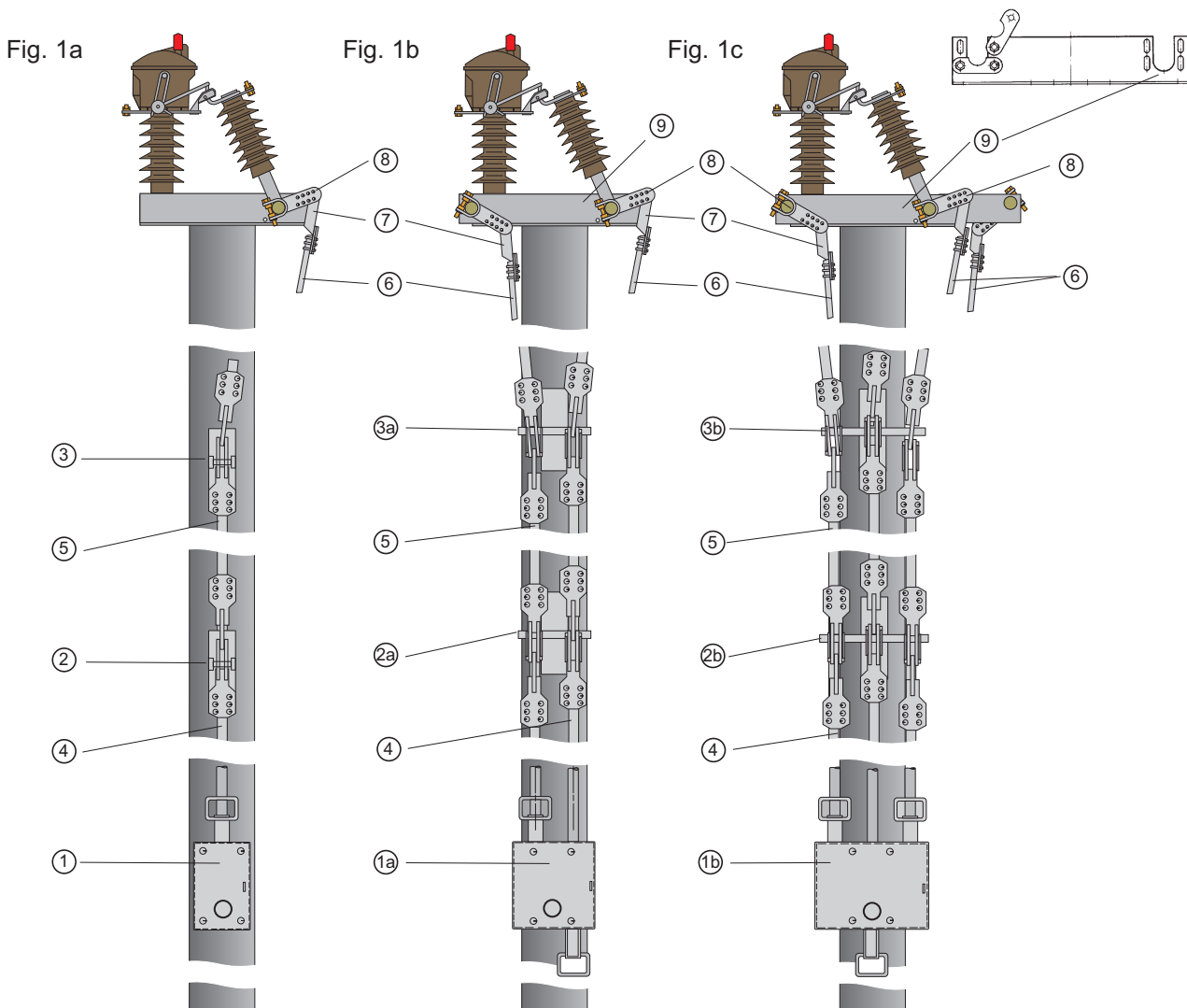

### Fastening of the switch

1. The fastening of the switch to the column is carried out using the 2 supports and M 20 x 400 threaded bolts ①.
2. Switch connection is carried out using the flexible copper strips ②, ③.
3. The fork-type lugs ④ are intended for fastening the copper strip.

### Assembly of operating mechanism

1. For operating the outdoor load-break switch, L-actuators or box-type actuators are available ⑨.
2. The operating mechanism and the intermediate bearings ⑤, ⑥ should be mounted at 45° to the cable run.
3. The operating mechanism should be fastened at a height of approx. 1250 mm above ground, and mounted to the column using drawstrings or M 16 screws.
4. For columns of an unsupported length of up to 10 m, the linkage will be guided by 2 single intermediate bearings ⑤, ⑥. Fastening of the bearings is also carried out using drawstrings or M 16 screws. The upper intermediate bearing ⑤ is provided with a link bushing which enables the linkage tube to deflect sideways. That bearing is marked with a red label.

### Note:

For the FLa 15/60 W type (horizontal), please make sure that the actuating crank for the post insulators is brought into dead-centre position to avoid any inadvertent closing of the switch in case there is a defect in the operating mechanism. For this reason, the actuating angle is 110°. (The function of a dead-centre circuit.)

5. The load-break switches have been designed so as to ensure that there is no need for linkage crimping. Please avoid crimping!
6. It is recommendable to mount the switch with the column in horizontal position. The linkage, however, may be tightened only with the column in vertical position. If the operating mechanism is mounted with the column standing upright, and set prior to the guying of the overhead conductors, readjustment of the operating mechanism after guying will be absolutely necessary.
7. The clamp-on crank ⑧ with clamping stub head ⑦ is to be mounted as closely as possible toward the central switch pole (for crank position, see illustration A).
8. The switch has been set correctly if it reaches the ON and OFF positions even when the actuator is being operated slowly in both directions. The end stops for the ON and OFF positions have been marked in a clearly visible manner on each switch.
9. Any tension in the linkage should be compensated for by loosening the clamping stub heads ⑦ of the intermediate bearings, with nuts to be retightened there after.
10. After several trial switching operations, all terminal and fixing screws, including those for clamping stub heads and clamp-on cranks, must be re-tightened.

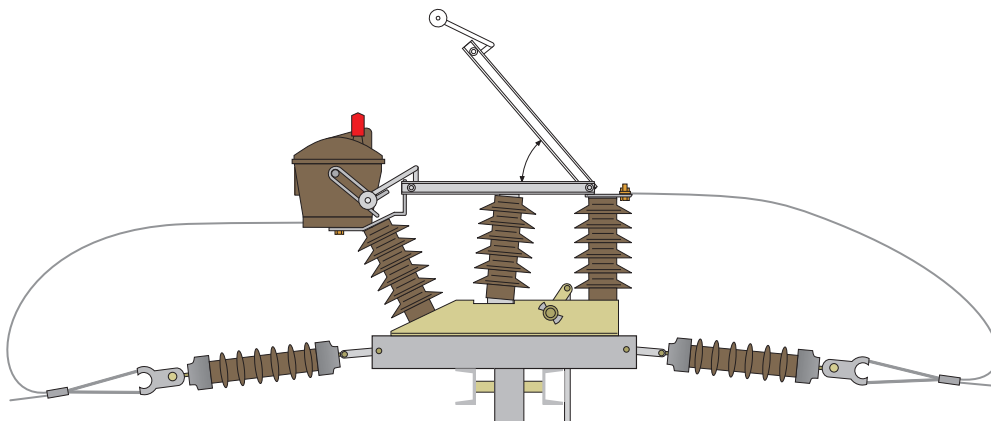

### Secondary connections (optional)

Provide the auxiliary switch connections as shown in the enclosed wiring diagram.

Secondary wires are to be shielded against the high voltage area.

### Testing the auxiliary switch: (optional)

The auxiliary switches are factory set and tested on all functions. A function check is to be done after the assembly works. Supposed that an auxiliary switch is mistakenly adjusted during transport or assembly works, it is to be checked and if necessary readjusted. Please contact DRIESCHER-Service.

Assembly instructions for Fla 15/97 with common base frame

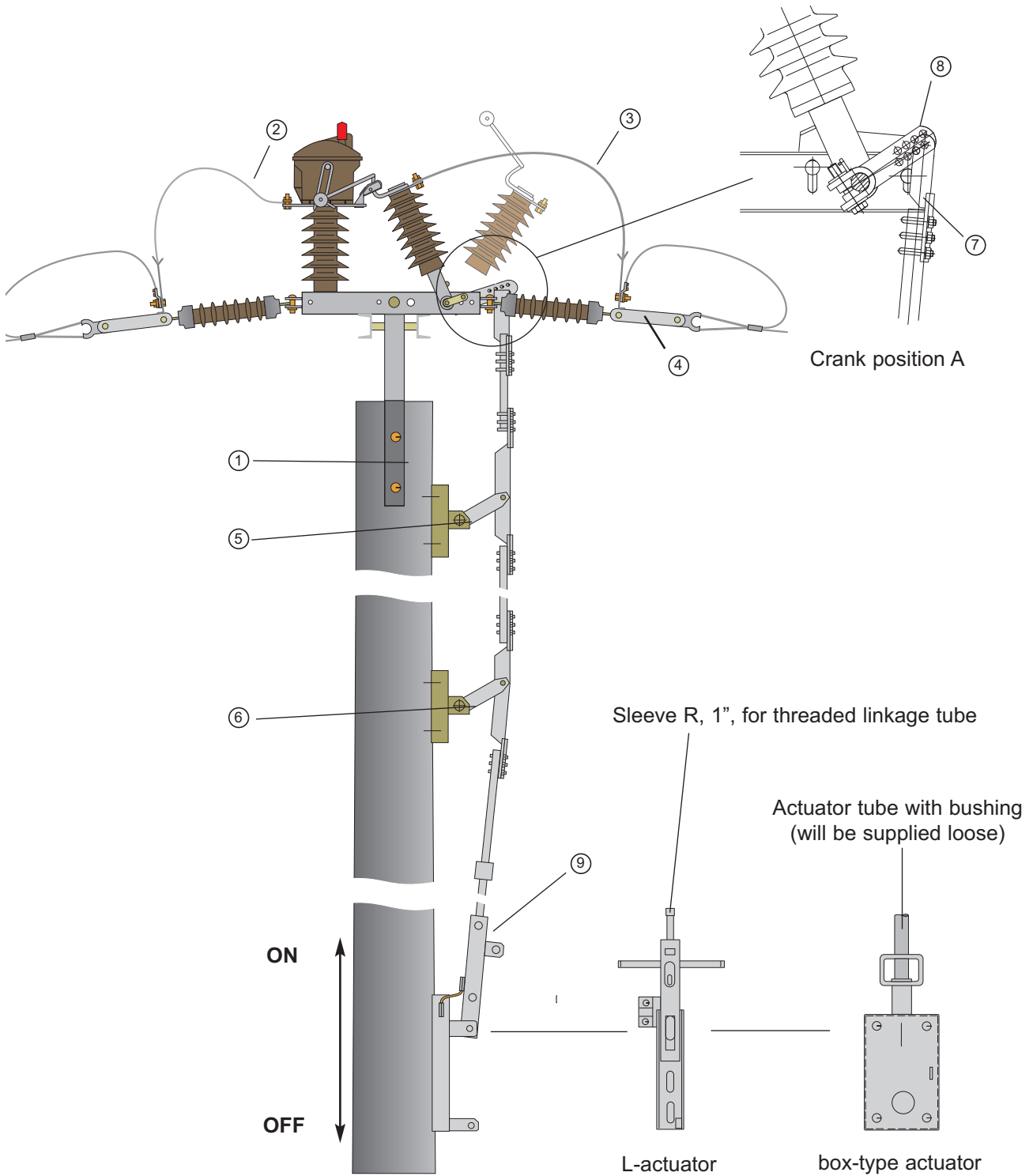

Service

Our specialist staff are ready to assist you on the phone, also out of office hours, should any malfunctions occur or if you have queries regarding compatibility, assembly or maintenance. Please always specify the data on the type plates. Tel. +49 (0) 87 61 6 81-0 Email: [service@driescher.de](mailto:service@driescher.de)

### General

Our products have been on the market for many years, and thousands of them are in operation. This is why we can claim that the quality of our products offers a high degree of robustness and operational dependability. In order to be able to guarantee that the requirements made on the units are met, and in order to avoid any power failures, we would like to state that for the purpose of a reliable energy supply, it will be necessary to subject the units to maintenance, inspection and, if appropriate, repair, depending on the operating time and operating frequency of the switchgear as well as on the amount of the nominal current switched

### Inspection

For load-break switches, inspection should, in addition to regular visual control, be carried out after approximately 10 years or 1000 operations even if the operating frequency of the switchgear is low, and only minor loads are applied.

Shorter intervals of inspection may apply in the event of:

- aggressive environmental impact;
- special cases of application;
- high operating frequency.

### Maintenance

Prior to commencing work, the working area must be isolated and safeguarded observing the 5 safety regulations in compliance with DGUV V3 (regulations of the statutory insurance institute of the industry). Always observe the local safety regulations.

Maintenance will essentially be limited to lubricating main contacts and bearings, as well as to the control and cleaning of insulating parts. It is necessary to check the oil level in the switching chamber after approximately 200 switching operations. The oil must be changed after 10 years of use.

In the event of fault, the complete chamber should be sent to the factory for overhaul work. After loosening the two fastening screws, it will be possible to remove the complete chamber.

- a) Clean the contacts using petroleum ether or special purifier, depending on the degree of soiling, and use a lubricant of low viscosity (recommended product: BARRIERTA L 55/1 made by the company Klüber).
- b) Check all bearings and links for ease of movement, and lubricate using Rivolta S.K.D. 16 N spray made by Bremer & Leguil.
- c) Clean the insulators if dirty.
- d) Check the unit for proper switching function by carrying out a few trial switching operations.
- e) Check all bolted connections, in particular the clamping screws on the actuator crank.

### Repair



**Please install and remove switchgear parts and accessories only after the switch has been set to OFF position, and the work area has been enabled and secured in accordance with regulations under DGUV V3.**

It is particularly because of the requirement of correct adjustment that disassembly as well as the installation or removal of switchgear (parts) should only be carried out by our DRIESCHER staff or professional personnel having received proper instructions.

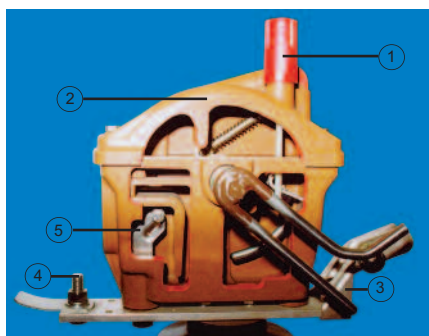

Switching chamber- sectional view

- ① Oil filling equipment with measuring rod and ventilation. For checking the oil level after approx. 200 switching operations, the ventilating equipment with measuring rod should be placed without screwing. The oil must be changed once in 10 years. Approximately 0,5 liter Shell Diala D oil is required per switching chamber.
- ② Switching chamber (sectional view)
- ③ Main contact with external spring
- ④ Connecting bar with screw
- ⑤ Secondary contact

Dimensions, weights, diagrams and descriptions in this brochure are non-binding. Subject to change without notice.

STROM • SICHER • SCHALTEN

Printed on chlorine free bleached paper. For nature's sake.

ELEKTROTECHNISCHE WERKE  
FRITZ DRIESCHER & SÖHNE GMBH

85366 Moosburg • Tel.: +49 8761 681-0 • Fax: +49 8761 681-137  
www.driescher.de info@service@driescher.de

