

Operating, Assembly and Maintenance Instructions for DRIESCHER Outdoor - Disconnectors

- 1-pole and 3-pole
- Rated voltage
12 kV up to 38,5 kV
- Rated current
400 A, 630 A and 1600 A

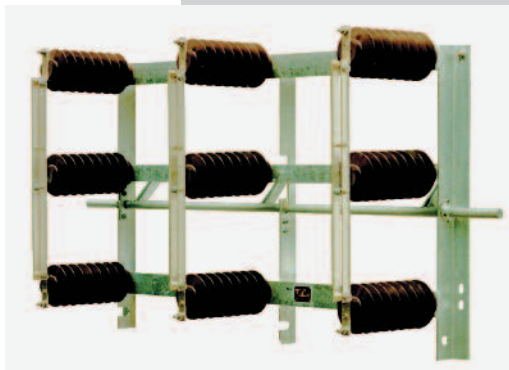

ELEKTROTECHNISCHE WERKE
FRITZ DRIESCHER & SÖHNE GMBH

D-85366 Moosburg • Phone: +49 8761 681-0 • Fax: +49 8761 681-137
www.driescher.com info@service@driescher.de



DRIESCHER - Outdoor disconnecter

acc. to EN 62271-102

Content

- 2 **General technical description, transport, storage**
- 3 **Operating conditions, maintenance**
- 4 **Mounting and Maintenance on Outdoor-disconnector FT_r**
- 5 **Mounting and Maintenance on Outdoor-disconnector FT**
- 6 **Measures for maintenance on the outdoor motor drive, Type UM 90**
- 7 **Measures for maintenance on the outdoor motor drive, Type UM 90**
- 8 **Overview of motor, manual emergency crank and lubricants, service**

**Warning**

During the operation of these electrical switches certain parts are inevitably exposed to dangerous voltage and mechanical parts may move very quickly, also under remote control. There is a risk of serious injury to the body or to property if the warning notes are not correctly observed. Only appropriately trained personnel as defined in VDE 0105 regulations are to work on this equipment or in the vicinity

thereof. These persons are to be completely familiar with all general regulations; VDE/IEC regulations, 5 safety regulations according to VDE, safety regulations, accident prevention regulations as well as all warnings and maintenance measures as specified in these operating instructions. Correct transport, appropriate storage, mounting and assembly as well as the correct operation and maintenance are prerequisites for the satisfactory and safe operation of this equipment.

General technical description

Driescher outdoor-switches in the 1- and 3-pole design are specifically designed for high supply reliability and comply with the specifications in accordance with EN 62271-102.

The switches can be used for a rated voltage range of U_r 12 kV up to 38.5 kV depending on the design and for a rated current of I_r 400 A, 630 A and 1600 A.

Switch design:

For the vertical assembly (wall mounting), the disconnecter with a switching angle of 90° is preferred. To ensure an independent closing in the horizontal mounting (pole mounting), switching angle of 110° is required on the actuating shaft.

The disconnecter blade set is directly actuated with the insulators by the actuating shaft.

The baseframe as well as all steel parts are provided with a galvanized surface protection acc. to DIN EN ISO 1461 or stainless steel, which provides excellent corrosion resistance.

The live parts are of electrolyte copper with elector silver plating in compliance with QTL 0200. For insulation to earth the insulators of cycloaliphatic cast resin are used, which has proved itself over the decades.

For rated voltage of 12 kV and 24 kV, a pollution degree of PD 3 (25 mm / kV) and for 38,5 kV a pollution degree of PD 2 (20 mm / kV) is specified as standard. (Higher pollution degree on request.)

Transport and Storage

Unpack the switches carefully after delivery and look out for any damage caused during transportation. If you discover any damage please report this immediately and contact the shipping company.

After unpacking, clean all switchgear equipment and accessories and remove any soiling through packing material, make sure to protect all equipment from dam-

age and contamination prior to installation.

Carefully clean switches and elements of the operating mechanism to remove dust and assembly swarf and clean all insulating parts with a clean dry cloth.

When transporting the switches only hold at the frame, **never** pick them up at the current paths (contact blades etc.).

Operation conditions

The use of switchgears under normal operating conditions is specified in the EN 62271-1 as follows:

- The maximum ambient temperature is 40 °C, the average value over a period of 24 h is max. 35 °C. The minimum ambient temperature is -25 °C. For our outdoor switches the class "Minus 25 outdoor" is specified.
- The altitude at the place of installation is max. 1000 m above sea level.
- The ambient air can be significantly polluted through dust, smoke, corrosive gasses, fumes or salts. The pollution should not exceed the pollution degree "II- medium" acc. to IEC 60815, table 1.
- Solar radiation with a power up to 1000 W/m² (on a clear day at midday) must be considered.
- The wind speed must not be exceeded 34 m/s (This corresponds to a wind pressure of 700 Pa on cylindrical surfaces).

Maintenance

General:

The outdoor disconnectors are manufactured by DRIESCHER in accordance with the EN specification EN 62271-102 valid at the time of the type tests. The disconnectors are classified in accordance with the mechanical endurance test for Class M2 (corresponding to 10000 switching operations).

Visual check, inspection

To carry out the annual recommended visual inspection the switch does not have to be safety isolated. For outdoor disconnectors check the following points to assess the general condition of the switch:

- Is there any external damage, wear (e.g. contact erosion etc.) or extreme contamination to be seen ?
- Does the switch attain the specified switching positions (ON and OFF) ?
- Are there any visible or audible discharge phenomena across isolating distances (e.g. sparking) ?

Repair work

Worn or damaged switch components are not to be repaired or reworked, but must be replaced with original DRIESCHER accessories.



Maintenance and repair measures as well as any subsequent conversion work is only to be carried out by the DRIESCHER-Service or by trained personnel authorised by us, due to the required skilled adjustment.

Maintenance



Prior to commencing work, the working area must be isolated and safeguarded observing the 5 safety regulations in compliance with DGUV V3 (regulations of the statutory insurance institute of the industry). Always observe the local safety regulations.

For outdoor-disconnectors:

Maintenance category	Maintenance interval
Inspection	Once a year (recommended)
Maintenance	as required, after 1.000 switching operations at the latest or 10 years after delivery
Corrective maintenance	as required, after 10.000 switching operations at the latest or 20 years after delivery

Mounting:

Unless specified otherwise, the switches with a switching angle of 90° are designed for vertical assembly on frames or walls. Disconnectors with a switching angle of 110° is for horizontal assembly application. Always observe the following when mounting the switches:

- It is recommended to mount the switches on precision aligned cross-rails.
- Do not distort the baseframe of the switch when tightening the fastening bolts (min. M12) (use shims if necessary).
- When connecting the connecting rails or cable end fittings there must be no thrust, pulling or twisting forces acting on the switch connections (hold in place with a second wrench!) Tighten connecting bolts M12 to a torque of 70 Nm.
- After completing the mounting carry out several test switching operations in de-energized condition. In order to do so, check whether the disconnecting blade pairs (3) are centred when they enter the impact contacts (4).

Providing earthing connections

There are appropriate bores provided in the baseframe for taking up the earthing screw M12.

The minimum cross section of the connection wires for equipotential bonding should be 50 mm².

When mounting on an earthed frame the required connection to earth can already be carried out using corresponding contact washers when fastening the switch.

Secondary connections (optional)

Provide the auxiliary switch connections as shown in the enclosed wiring diagram.

Secondary wires are to be shielded against the high voltage area.

Commissioning:

The function test must be carried out in off-load condition. In doing so, make sure that in the On and Off switching the end stop positions (9) of the operating shaft (11) are reliably attained.

Checking the motor drive (optional)

Before the motor drive is electrically operated, the mechanical function of all actuator and bearing components, as well as the actuator rods should be checked by slowly operating it with the manual emergency crank. On adjusting the motor drive components, pay attention that position ON and OFF (9) are reached. It is possible to correct the movement of the actuating rod by changing the hanging point of the actuating crank.

With motor actuator, the actuating shaft (11) of the disconnector must move without any malfunction in both the end positions, with a rated-operating voltage of 85 % and 110 %. Here a proper ON and OFF function (9) of the disconnector should be checked.

Testing the auxiliary switch: (optional)

The auxiliary switches (6) are factory set and tested on all functions. A function check is to be done after the assembly works. Supposed that an auxiliary switch is mistakenly adjusted during transport or assembly works, it is to be checked and if necessary readjusted. Please contact DRIESCHER-Service.

Earthing switch (optional)

Maintenance instructions according to the instructions for disconnectors.

Visual check / inspection

The required measures are specified on Page 3. In addition to this, these outdoor disconnectors are to be inspected after every switching operation under short circuit conditions.

The possible need for maintenance or repair cannot be ruled out due to the exceptional load.

Maintenance:

- Check all screw connections of the connecting rails and the switch mounting.
- Lubricate all friction bearings (5) of the operating shafts (7 + 11) and all moving connection bolts with Rivolta S.K.D. 16 N.
- Clean connecting rails and insulators (1) with Rivolta M.T.X 60 forte (of Bremer & Leguil) and then dry them with a cloth.
- Check that the contact blades (3) strike correctly in the centre of the contact jaw (4) (by applying slow manual emergency operation).
- Clean the contact surface on the disconnecting blade set (3a) and the contact jaw (4) with the cleaning agent Rivolta S.L.X. 500 S (Fa. Bremer & Leguil).
- Check wear of contact surfaces (3a) on the contact blade set (3) and at the contact jaw (4), replace contact blade set if necessary. (Always consult DRIESCHER-Service).
- If there is excessive wear of the silver plating (copper is visible) replace the contact parts (2, 3 and 4). (Always consult DRIESCHER-Service).
- Lubricate contact surfaces (2, 3a and 4) very thinly with Barrierta (of Klüber Lubrication).
- Prior to commissioning carry out several test switching operations and check for satisfactory switching function.

Mounting and Maintenance on Outdoor-disconnector FTr

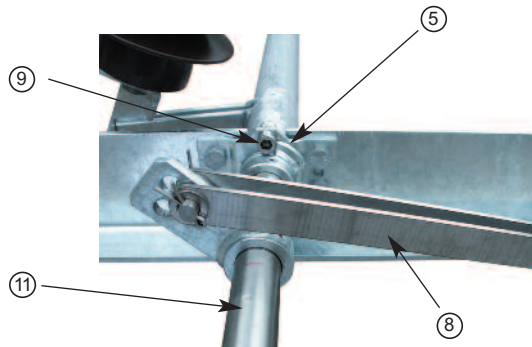
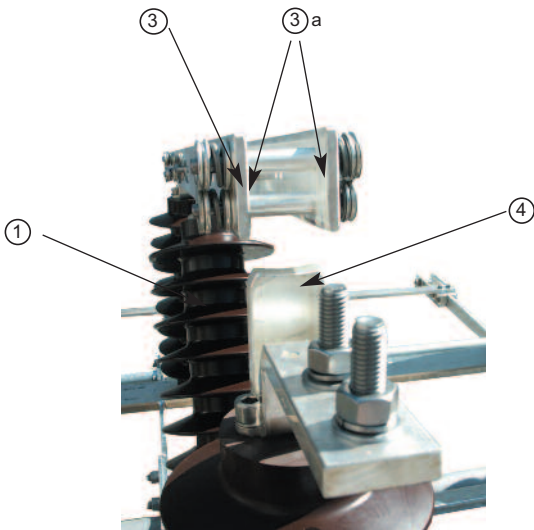
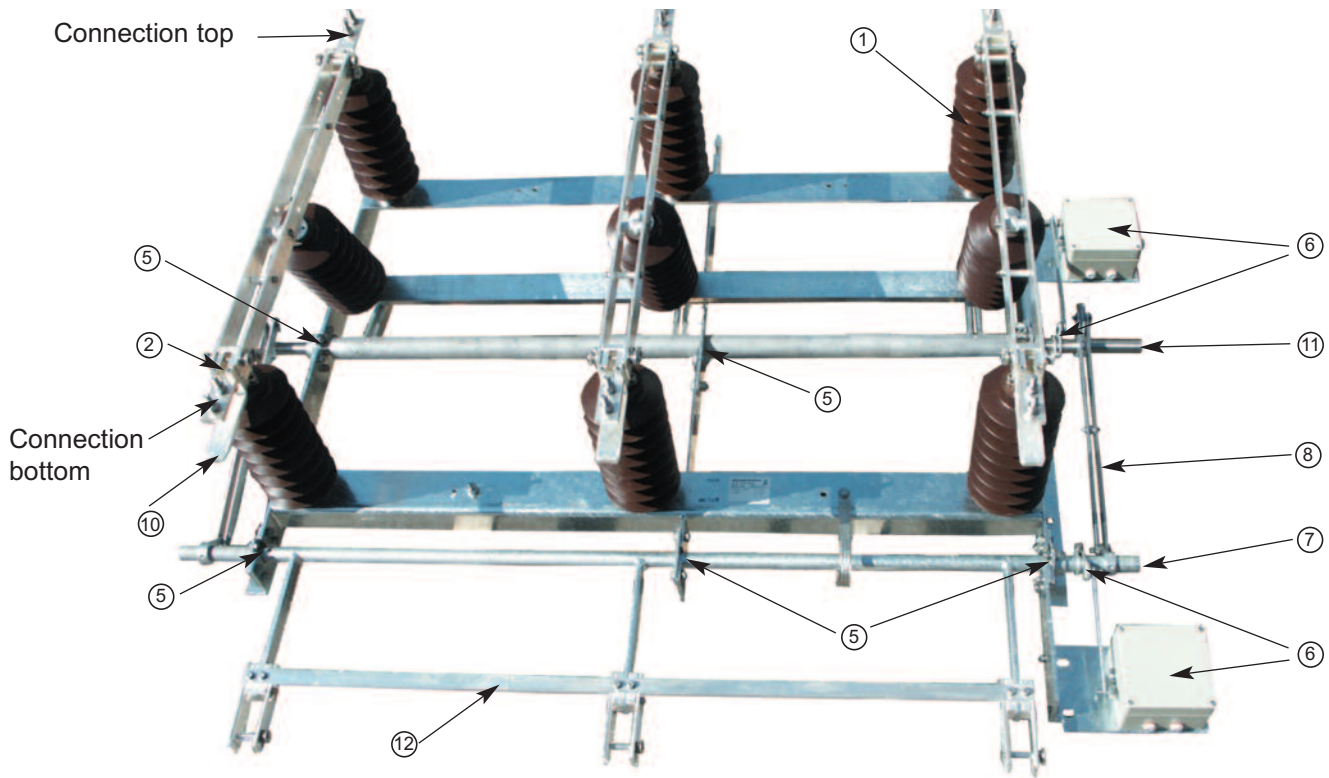

- ① Insulators
- ② Pivot contact
- ③ Disconnecting blade set
- ③^a Contact surface on disconnecting blade set
- ④ Contact jaw
- ⑤ Bearing points of operating shaft
- ⑥ Auxiliary switch with operating components (optional)
- ⑦ Operating shaft earthing switch (optional)
- ⑧ Connection rod for automatic earthing switch (optional)
- ⑨ Limited stop of the operating shaft
- ⑩ Earthing jaw (optional)
- ⑪ Operating shaft disconnector
- ⑫ Automatic earthing switch (optional)

1. Visual check, inspection

The mounted motor drives are designed for a service life of 10.000 switching operations. In the annual visual inspection you should inspect and assess the general condition of the motor-operated mechanism on the inside and outside. When doing so, pay attention to the following points:

- General inspection for traces of external damage
- Does the operating shaft of the switch extend right into both end stop positions ?

If any deviations are ascertained within the scope of the visual inspection, appropriate further measures must be taken.

2. Maintenance

Under normal ambient conditions, the motor drive is maintenance-free up to 10.000 switching cycles. At unfavorable conditions and/or increased mechanical loads, a maintenance service is recommended after 5.000 switching cycles. This includes the following work in addition to the visual inspection.

Lubricate the following components with the lubricant Isoflex NBU 15 (of Klüber Lubrication):

- Guide rollers (d) on both sides on the driver pin (b), as well as the guide rails (f) and forked link (g) interacting with the guide rollers.
- Ball-and-screw spindle drive (e), as well as both roller bearings (h).
- Sliding sleeve (T) and Bevel gearing (i) (for this purpose the covering (j) first has to be removed) on the manual emergency operating mechanism.

Caution!

To ensure satisfactory operation of the friction clutch (3) it **should not come into contact with the lubricant.**

- The motor with gear box (F) has lifetime lubrication.
- Function check of the limit switches (c) and the safety switch (U), for smooth operation.

Measures for maintenance on the outdoor motor drive, Type UM 90

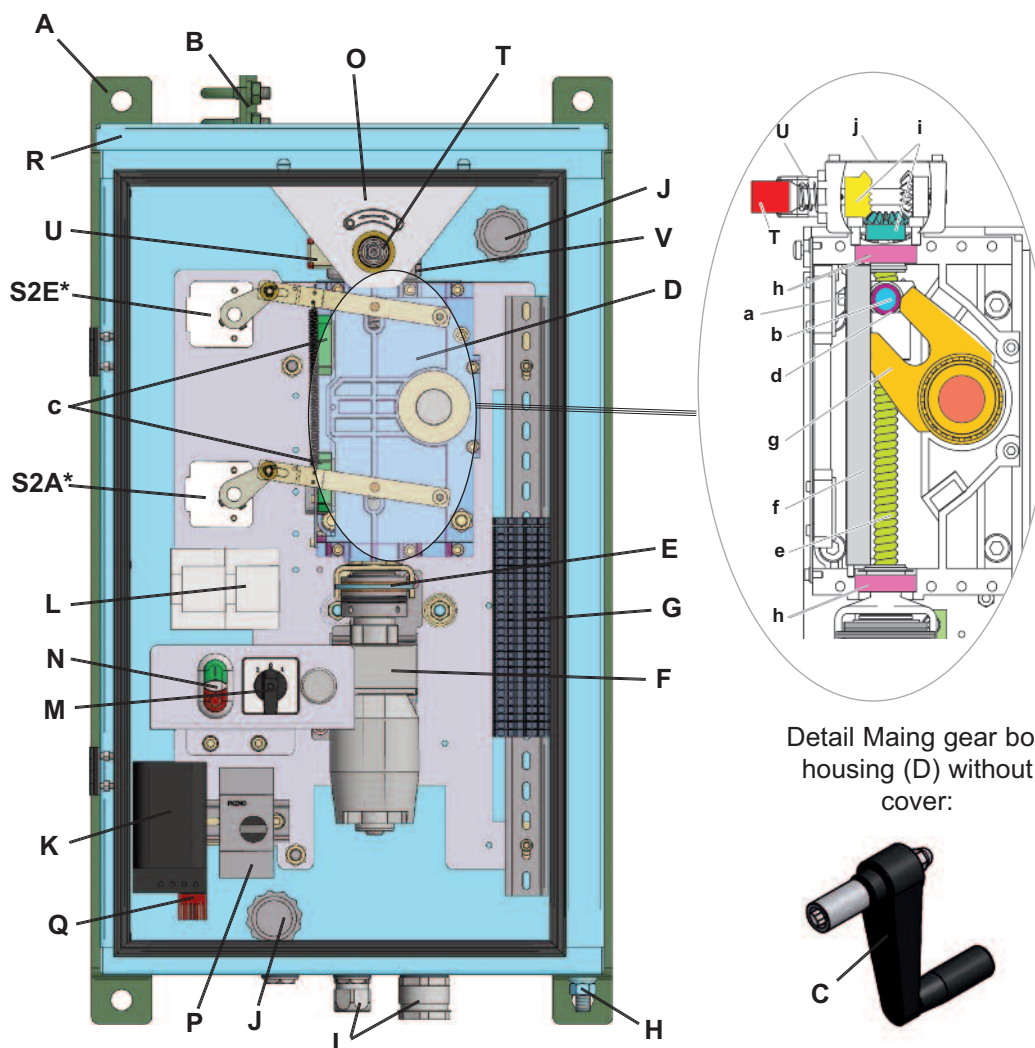

Detail Maing gear box housing (D) without cover:

- | | | | |
|---|--|------|---|
| A | Support frame | Q | Thermostat / Hygrostat ¹ |
| B | Head of clamping rod (for linkage pipe 1") | R | Stainless steel housing |
| C | Emergency hand crank | S2A* | Pilot switch motor drive position „OFF“ |
| D | Main gear box | S2E* | Pilot switch motor drive position „ON“ |
| E | Friction clutch | T | Sliding sleeve |
| F | Motor with gear box | U | Safety switch emergency hand crank |
| G | Terminal connections | V | Emergency hand crank housing |
| H | Earthing terminal | a | Driver |
| I | Cable entry max. 4xM25, 2xM32 | b | Driver pin |
| J | Ventilation | c | Pilot switches |
| K | Heating | d | Guiderollers |
| L | Control contactor | e | Ball and screw spindle drive |
| M | Change over switch Local/Remote/Off | f | Guide rails |
| N | Local ON/OFF push button ¹ | g | Conneting fork |
| O | Guiding plate for emergency hand crank with rotation direction indicator | h | Rolling-contact bearing |
| P | Protective motor switch ¹ | i | Bevel gearing |
| | | j | Covering |

¹ as option

* corresponding for sense of rotation „B“ (reverse for sense of rotation „A“)

Overview of used hand emergency cranks for motor-operated mechanism UM 90

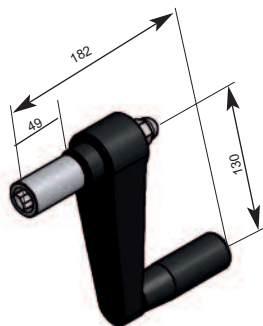

L: Lenght	Part-no.:	Drawing-no.:
182 mm	2-77601001	036348-001

Overview of used lubricants and cleaning agents

Part-no.:	Lubricant designation/Type	Manufacturer
1-49007110	Rivolta S.K.D. 16 N	Fa. Bremer & Leguil
1-49007100	Rivolta S.K.D. 4002	Fa. Bremer & Leguil
1-49007015	Isoflex NBU 15	Fa. Klüber Lubrication
1-49009100	Rivolta M.T.X. 60 forte	Fa. Bremer & Leguil
1-49007010	Barrierta L55/1	Fa. Klüber Lubrication
1-49009102	Rivolta S.L.X. 500 S (cleaning agent)	Fa. Bremer & Leguil

Service

Our specialist staff are ready to assist you on the phone, also out of office hours, should any malfunctions occur or if you have queries regarding compatibility, assembly or maintenance.

Please always specify the data on the type plates.

Tel. +49 (0) 87 61 6 81-0 Email: service@driescher.de

Dimensions, weights, diagrams and descriptions in this brochure are non-binding. Subject to change without notice.

STROM • SICHER • SCHALTEN

Printed on chlorine free bleached paper. For nature's sake.

**ELEKTROTECHNISCHE WERKE
FRITZ DRIESCHER & SÖHNE GMBH**

D-85366 Moosburg • Phone: +49 8761 681-0 • Fax: +49 8761 681-137
www.driescher.com infoservice@driescher.de

